

Force Rating	725 lb.	Max. Pressure	80 psi
Bin Weight Capacity	7250 lb.	Max. Temp.	350 °F
Speed @ 80 psi	5200 VPM	Speed @ 60 psi	4600 VPM
dB @ 80 psi	72	dB @ 60 psi	-
CFM @ 80 psi	10	CFM @ 60 psi	8

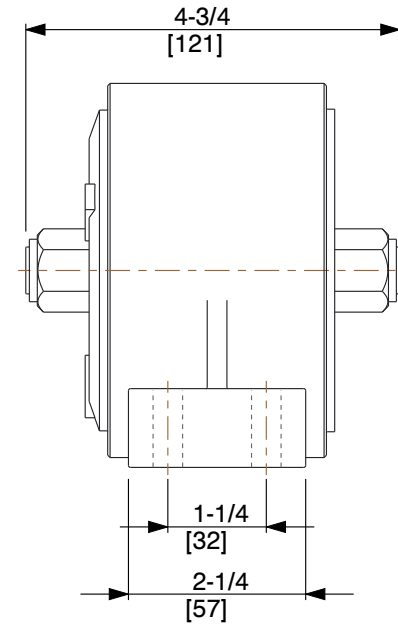
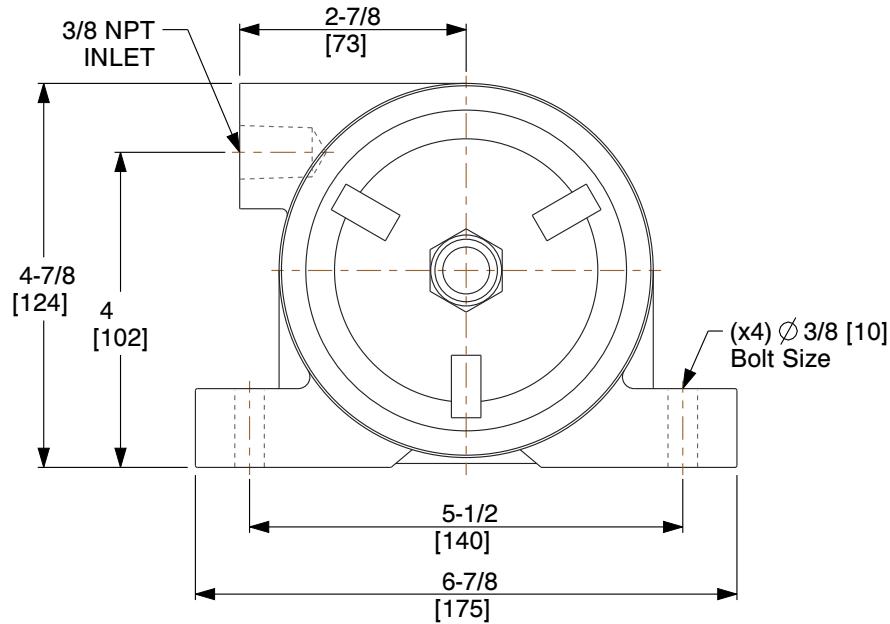

**NOTES:**

1. MOUNTING: Foot
2. MUFFLER: Included
3. DUTY: Continuous
4. VIBRATOR TYPE: Turbine
5. HOUSING MATERIAL: Cast Iron
6. MOUNTING PLATE: Sold Separately
7. STANDARDS: CE Certified, ATEX Certified

<b>COMPONENT</b>	Pneumatic Vibrator
------------------	--------------------



100 Grainger Parkway, Lake Forest, Illinois 60045-5201  
 1-(800) GRAINGER, 1-(800) 472-4643, (847) 535-1000  
 www.grainger.com

This file and any associated information and specifications are provided for reference and evaluation purposes only, and is subject to change without notice. Grainger makes no representations, warranties or guarantees as to the appropriateness, accuracy, completeness, or suitability for any purpose, of the file, information or specifications. You are solely responsible for the use of the file, information or specifications.

This drawing is the property of GRAINGER. It contains confidential, proprietary information that is GRAINGER property. Do not disclose to or duplicate for others except as authorized by GRAINGER.

**SCALE** 0.410

<b>6L750</b> PNEUMATIC VIBRATOR, 725 LB, 4600 VPM, 80 PSI
---

<b>UNIT</b>
INCH [MM]
<b>SHEET</b>
1 of 1