

HP	1/3	dBA	62 @ 3 ft.
Phase	3	Max. Temp.	200 °F
Amps	1.0/0.5	Force Rating	180 to 400 Lb.
Voltage	230/460 VAC	Power Source	Electric
Speed	3600 VPM	Bin Weight Capacity	4500 Lb.

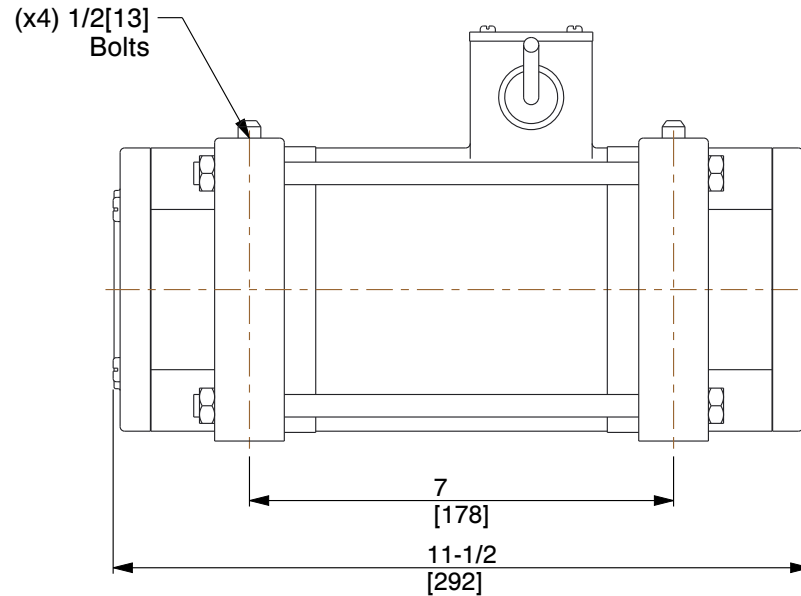
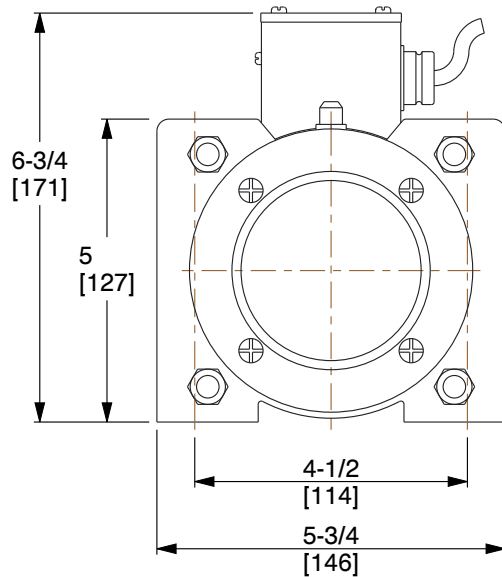

NOTES:

1. VIBRATOR TYPE: Heavy Duty
2. BEARING TYPE: Prelubricated
3. STANDARDS: ASTM and ASME
4. FORCE: Mechanically Adjustable
5. MOUNTING POSITION: Universal
6. MOUNTING PLATE: Sold Separately
7. ENCLOSURE: Totally Enclosed Non-Ventilated
8. DUTY: Continuous Only at Certain Force Settings, Intermittent Duty at Maximum Force Settings

COMPONENT	Electric Vibrators
------------------	--------------------



100 Grainger Parkway, Lake Forest, Illinois 60045-5201
 1-(800) GRAINGER, 1-(800) 472-4643, (847) 535-1000
 www.grainger.com

This file and any associated information and specifications are provided for reference and evaluation purposes only, and is subject to change without notice. Grainger makes no representations, warranties or guarantees as to the appropriateness, accuracy, completeness, or suitability for any purpose, of the file, information or specifications. You are solely responsible for the use of the file, information or specifications.

This drawing is the property of GRAINGER. It contains confidential, proprietary information that is GRAINGER property. Do not disclose to or duplicate for others except as authorized by GRAINGER.

SCALE 0.316

6L742 ELECTRIC VIBRATOR, 1.0/0.5A, 460V, 3-PHASE

UNIT
INCH [MM]
SHEET
1 of 1