

Item	Hydraulic Gear Pump	Ports (Outlet)	3/4" NPTF
Type	Two Stage	Mounting Flange	SAE A
Rotation	Clockwise	Nominal Flow (GPM)	22
Input RPM	3600	Max. PSI 1st Stage	750
Ports (Inlet)	1" NPTF	Max. PSI 2nd Stage	3000

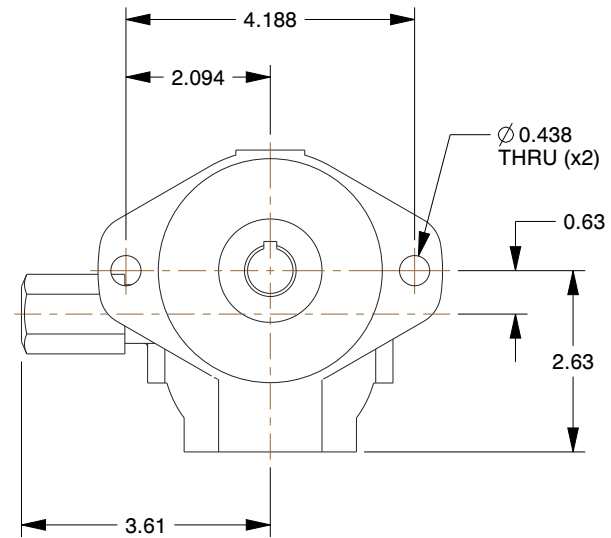
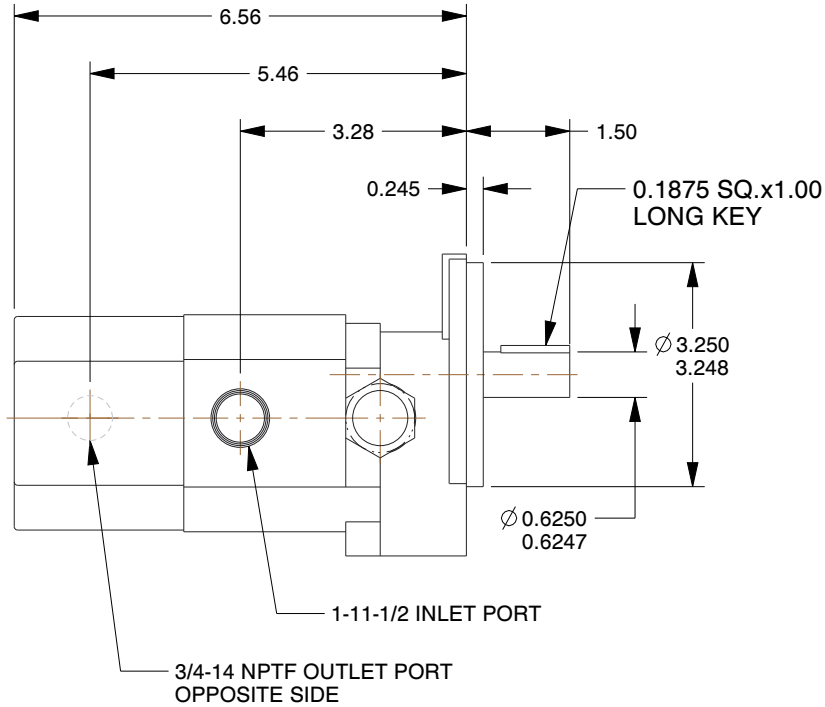

NOTES:

1. DRIVE: Direct
2. GPM @ 1000 PSI: 6.7
3. GPM @ 2000 PSI: 6.3
4. GPM @ 250 PSI: 22
5. HP REQUIRED: 15
6. DRIVE SHAFT (IN.): 5/8
7. TRANSMISSION: 2 Stage
8. UNLOADING VALVE PRESET PRESSURE (PSI): 650
9. DISPLACEMENT @ HIGH PRESSURE (CUBIC INCHES/REV.): 0.465
10. DISPLACEMENT @ LOW PRESSURE (CUBIC INCHES/REV.): 0.93
11. APPLICATION: For Presses, Log Splitters, Clamping Units and Compactors

COMPONENT	Hydraulic Two Stage Gear Pumps
------------------	--------------------------------



100 Grainger Parkway, Lake Forest, Illinois 60045-5201
1-(800) GRAINGER, 1-(800) 472-4643, (847) 535-1000
www.grainger.com

This file and any associated information and specifications are provided for reference and evaluation purposes only, and is subject to change without notice. Grainger makes no representations, warranties or guarantees as to the appropriateness, accuracy, completeness, or suitability for any purpose, of the file, information or specifications. You are solely responsible for the use of the file, information or specifications.

This drawing is the property of GRAINGER. It contains confidential, proprietary information that is GRAINGER property. Do not disclose to or duplicate for others except as authorized by GRAINGER.

SCALE 0.36

Gear Pump, 2 Stage, 3600 RPM, 22 GPM

5ZPL6

UNIT

INCH

SHEET

1 of 1