

Groove Provided for 82.6 [3.25] 2.62 [0.103] Cross Section O-ring

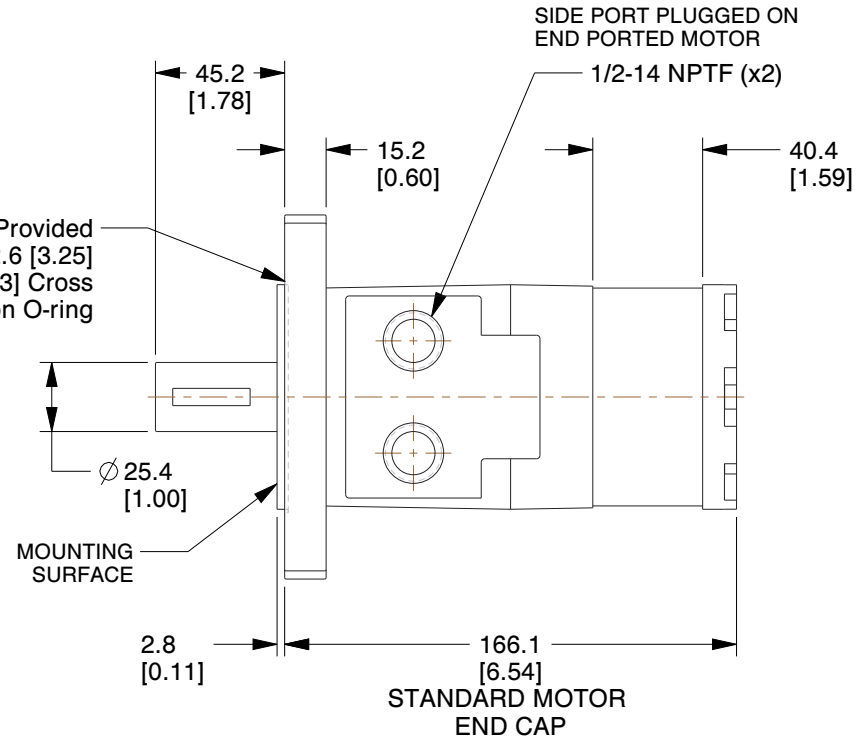

NOTES:

1. SERIES: H
2. MAX. RPM: 192
3. PORT TYPE: Side
4. SHAFT TYPE: Keyed
5. ITEM: Hydraulic Motor
6. PORT THREAD: 1/2-14 NPTF
7. MAX. OIL TEMP. (F): 180
8. MIN. OIL VISCOSITY: 100 SUS
9. CONTINUOUS TORQUE: 3110 in.-lb.
10. PRESSURE RATING (PSI): 1800
11. FLANGE MOUNT: 2 Bolt, 3.25" Pilot
12. DISPLACEMENT (CU. IN./REV.): 17.9

COMPONENT	General Purpose Hydraulic Motors
------------------	----------------------------------



100 Grainger Parkway, Lake Forest, Illinois 60045-5201
 1-(800) GRAINGER, 1-(800) 472-4643, (847) 535-1000
 www.grainger.com

This file and any associated information and specifications are provided for reference and evaluation purposes only, and is subject to change without notice. Grainger makes no representations, warranties or guarantees as to the appropriateness, accuracy, completeness, or suitability for any purpose, of the file, information or specifications. You are solely responsible for the use of the file, information or specifications.

This drawing is the property of GRAINGER. It contains confidential, proprietary information that is GRAINGER property. Do not disclose to or duplicate for others except as authorized by GRAINGER.

SCALE 0.36

5PZH1

Hydraulic Motor, 17.9 cu in/rev, 2 Bolt

UNIT	INCH
SHEET	1 of 1