

|                    |                    |                            |      |
|--------------------|--------------------|----------------------------|------|
| Speed Reducer Type | C-Face             | Max. Output Torque (in-lb) | 1233 |
| Shaft Orientation  | Right Angle        | Overhung Load (lb.)        | 967  |
| NEMA/IEC Frame     | 56C                | Nominal Output RPM         | 35   |
| Standards          | AGMA               | Number of Stages           | 1    |
| Seal Type          | Double Lip         | Max. Input HP              | 1    |
| Rotation           | Forward/Reversible | Nominal Ratio              | 50:1 |
| Duty               | Standard           | Input RPM                  | 1750 |

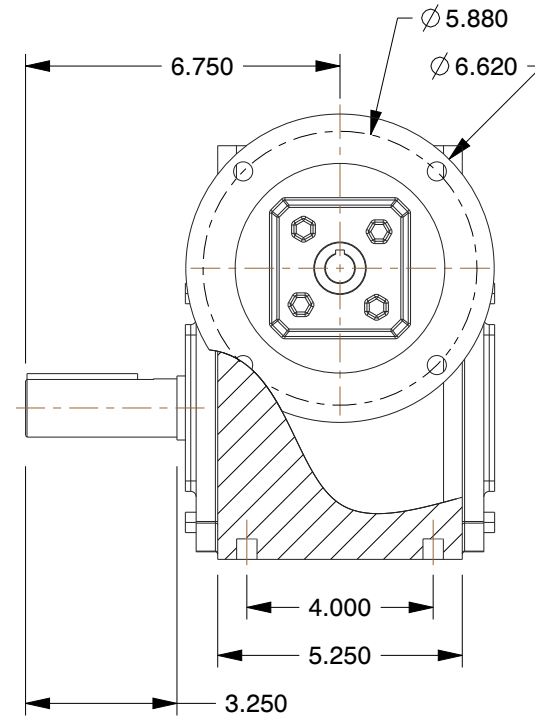
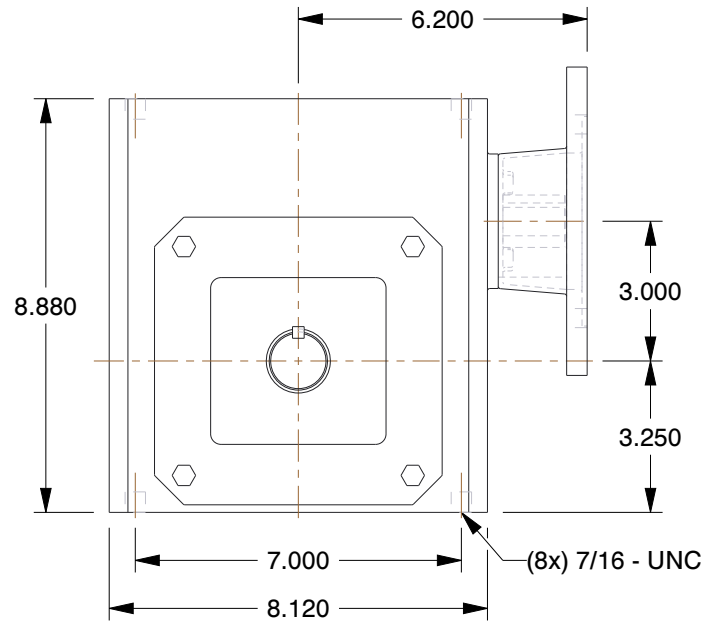
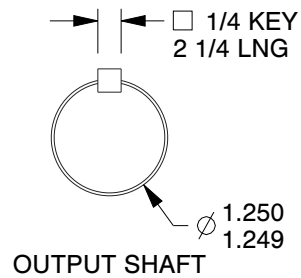

**NOTES:**

1. BEARINGS: Ball
2. GEAR TYPE: Worm
3. FINISH: Powdered Epoxy Paint
4. HOUSING MATERIAL: Cast Iron
5. WORM GEAR MATERIAL: Bronze
6. PINION MATERIAL: Hardened Steel
7. OUTPUT/SHAFT TYPE: SingleSolid
8. LUBRICATION: Klubersynth UH1 6-614
9. GEAR MATERIAL: Hardened and Ground Steel
10. MOUNTING: Any Position Except Input Motor Shaft Up
11. OUTPUT TORQUE (in.-lb.)
  - @ 1/2 HP 566
  - @ 3/4 HP 900
  - @ 1 HP 1233

|           |               |
|-----------|---------------|
| COMPONENT | Speed Reducer |
|-----------|---------------|



100 Grainger Parkway, Lake Forest, Illinois 60045-5201  
1-(800) GRAINGER, 1-(800) 472-4643, (847) 535-1000  
www.grainger.com

This file and any associated information and specifications are provided for reference and evaluation purposes only, and is subject to change without notice. Grainger makes no representations, warranties or guarantees as to the appropriateness, accuracy, completeness, or suitability for any purpose, of the file, information or specifications. You are solely responsible for the use of the file, information or specifications.

This drawing is the property of GRAINGER. It contains confidential, proprietary information that is GRAINGER property. Do not disclose to or duplicate for others except as authorized by GRAINGER.

SCALE 0.24

**4RP51**

Speed Reducer, C-Face, 56C, 50:1

UNIT  
INCH  
SHEET  
1 of 1