

Force Rating	1000 lb.	Max. Pressure	80 psi
Bin Weight Capacity	10,000 lb.	Max. Temp.	350 °F
Speed @ 80 psi	4500 VPM	Speed @ 60 psi	4000 VPM
dB @ 80 psi	77	dB @ 60 psi	-
CFM @ 80 psi	21	CFM @ 60 psi	18

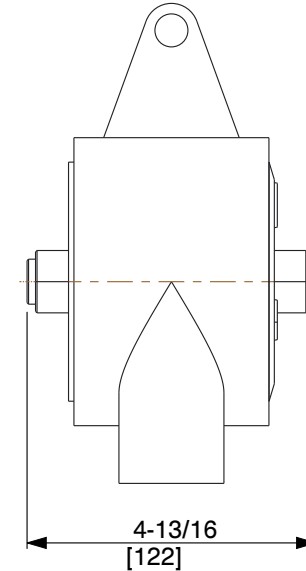
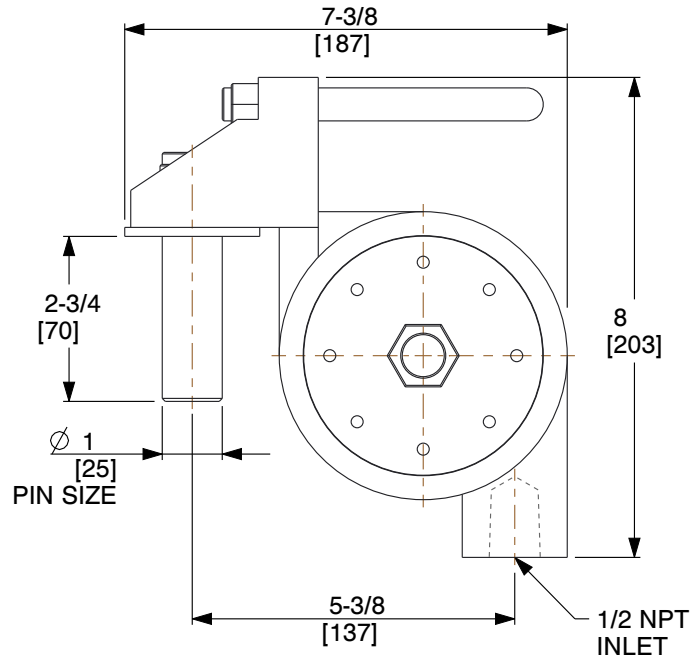

**NOTES:**

1. DUTY: Continuous
2. MUFFLER: Included
3. VIBRATOR TYPE: Turbine
4. HOUSING MATERIAL: Cast Iron
5. MOUNTING PLATE: Sold Separately
6. STANDARDS: CE Certified, ATEX Certified

<b>COMPONENT</b>	Pneumatic Vibrator
------------------	--------------------



100 Grainger Parkway, Lake Forest, Illinois 60045-5201  
 1-(800) GRAINGER, 1-(800) 472-4643, (847) 535-1000  
 www.grainger.com

This file and any associated information and specifications are provided for reference and evaluation purposes only, and is subject to change without notice. Grainger makes no representations, warranties or guarantees as to the appropriateness, accuracy, completeness, or suitability for any purpose, of the file, information or specifications. You are solely responsible for the use of the file, information or specifications.

This drawing is the property of GRAINGER. It contains confidential, proprietary information that is GRAINGER property. Do not disclose to or duplicate for others except as authorized by GRAINGER.

**SCALE** 0.313

<h1>4HV37</h1> <p>PNEUMATIC VIBRATOR, 1000 LB, 4000 VPM, 80 PSI</p>	<b>UNIT</b>
	INCH [MM]
	<b>SHEET</b>
	1 of 1