

Force Rating	160 lb.	Max. Pressure	80 psi
Bin Weight Capacity	1600 lb.	Max. Temp.	350 °F
Speed @ 80 psi	11,000 VPM	Speed @ 60 psi	9500 VPM
dB @ 80 psi	70	dB @ 60 psi	-
CFM @ 80 psi	2.5	CFM @ 60 psi	2.3

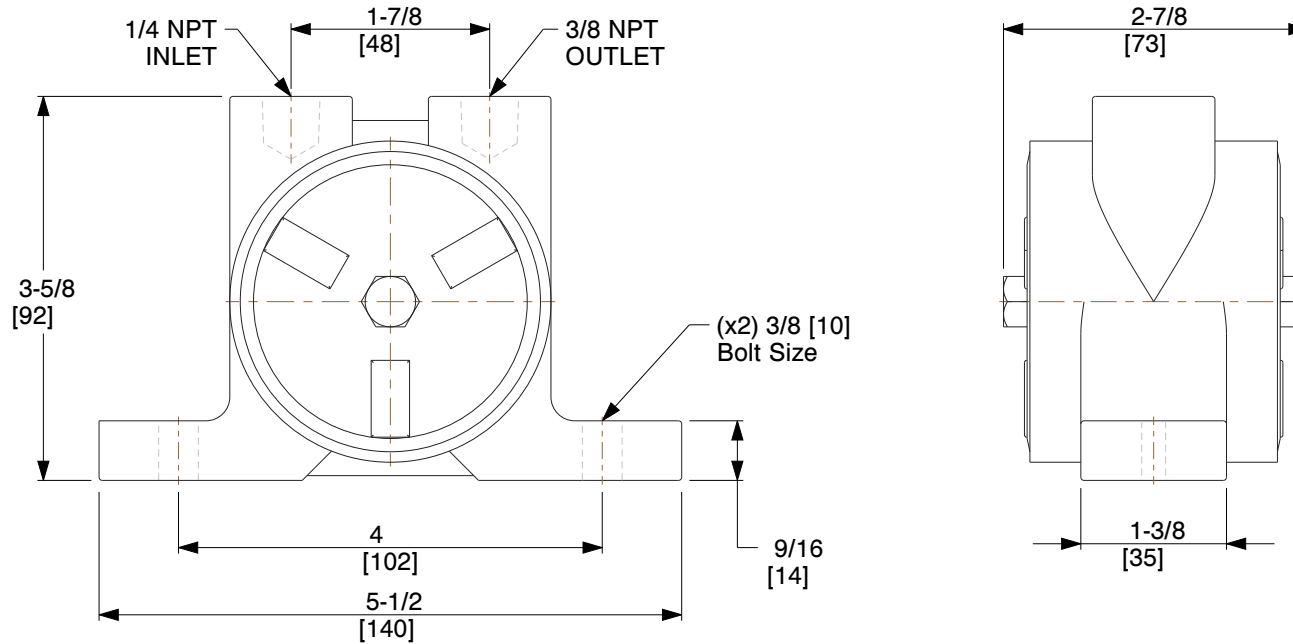

NOTES:

- MUFFLER: 1A327
- DUTY: Continuous
- VIBRATOR TYPE: Turbine
- BEARING TYPE: Oversized
- HOUSING MATERIAL: Cast Iron
- MOUNTING PLATE: Sold Separately
- STANDARDS: CE Certified, ATEX Certified

COMPONENT	Pneumatic Vibrator
-----------	--------------------



100 Grainger Parkway, Lake Forest, Illinois 60045-5201
 1-(800) GRAINGER, 1-(800) 472-4643, (847) 535-1000
 www.grainger.com

This file and any associated information and specifications are provided for reference and evaluation purposes only, and is subject to change without notice. Grainger makes no representations, warranties or guarantees as to the appropriateness, accuracy, completeness, or suitability for any purpose, of the file, information or specifications. You are solely responsible for the use of the file, information or specifications.

This drawing is the property of GRAINGER. It contains confidential, proprietary information that is GRAINGER property. Do not disclose to or duplicate for others except as authorized by GRAINGER.

SCALE 0.552

<h1>4HT96</h1> <p>PNEUMATIC VIBRATOR, 160 LB, 9500 VPM, 80 PSI</p>	UNIT
	INCH [MM]
	SHEET
	1 of 1