

HP	1/100	dBA	45
Phase	1	Max. Temp.	104 °F
Amps	0.5	Force Rating	20 Lb.
Voltage	115 VAC	Power Source	Electric
Speed	1600 VPM	Bin Weight Capacity	150 Lb.

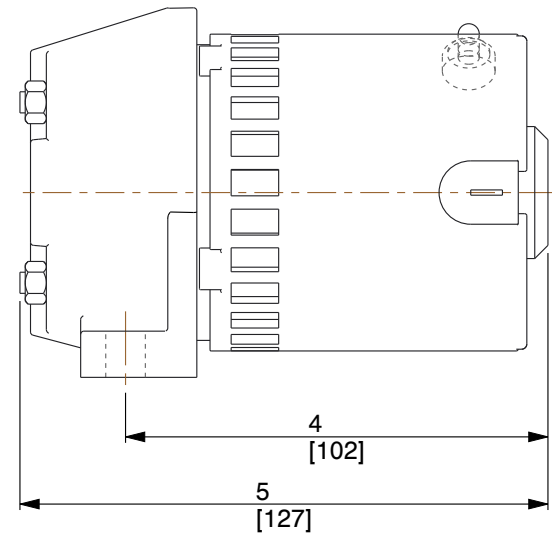
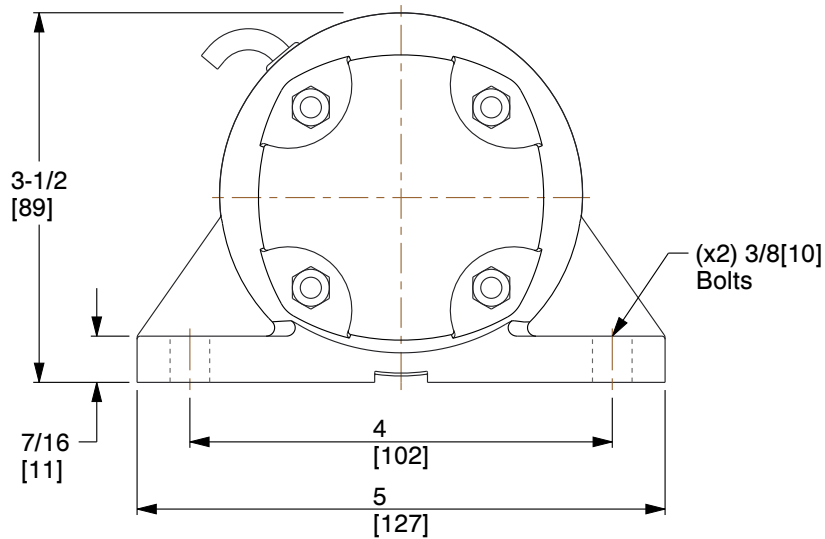

**NOTES:**

1. ENCLOSURE: Open
2. BEARING TYPE: Oversized
3. VIBRATOR TYPE: Compact
4. STANDARDS: ASTM and ASME
5. END BELL MATERIAL: Cast Iron
6. HOUSING MATERIAL: Aluminum
7. FORCE: Mechanically Adjustable
8. MOUNTING POSITION: Universal
9. MOUNTING PLATE: Sold Separately
10. DUTY: Continuous Only at Certain Force Settings, Intermittent Duty at Maximum Force Settings

<b>COMPONENT</b>	Electric Vibrators
------------------	--------------------



100 Grainger Parkway, Lake Forest, Illinois 60045-5201  
 1-(800) GRAINGER, 1-(800) 472-4643, (847) 535-1000  
 www.grainger.com

This file and any associated information and specifications are provided for reference and evaluation purposes only, and is subject to change without notice. Grainger makes no representations, warranties or guarantees as to the appropriateness, accuracy, completeness, or suitability for any purpose, of the file, information or specifications. You are solely responsible for the use of the file, information or specifications.

This drawing is the property of GRAINGER. It contains confidential, proprietary information that is GRAINGER property. Do not disclose to or duplicate for others except as authorized by GRAINGER.

**SCALE**      0.550

<h1 style="margin: 0;">4HR12</h1> <p style="margin: 0;">ELECTRIC VIBRATOR, 0.50A, 115VAC, 1-PHASE</p>
---

<b>UNIT</b>
INCH [MM]
<b>SHEET</b>
1 of 1