

HP	-	dBA	74
Phase	1	Max. Temp.	104 °F
Amps	16/8	Force Rating	350 Lb.
Voltage	12 VDC	Power Source	-
Speed	4000 VPM	Bin Weight Capacity	3000 Lb.

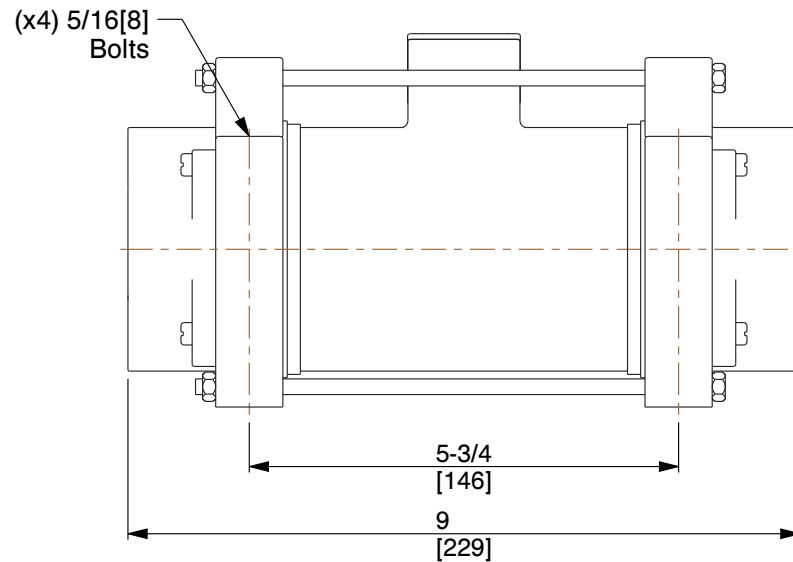
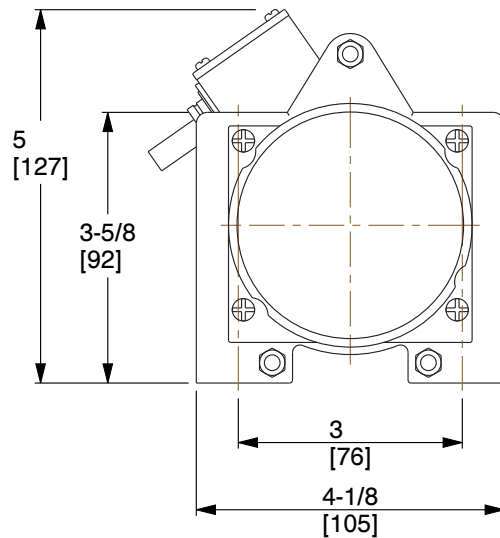

NOTES:

1. DUTY: Continuous
2. BEARING TYPE: Prelubricated
3. ENCLOSURE: Totally Enclosed
4. END BELL MATERIAL: Cast Iron
5. FORCE: Mechanically Adjustable
6. MOUNTING POSITION: Universal
7. VIBRATOR TYPE: Battery Operated
8. MOUNTING PLATE: Sold Separately
9. POWER SOURCE: Electric - 12VDC Battery

COMPONENT	Electric Vibrators
------------------	--------------------



100 Grainger Parkway, Lake Forest, Illinois 60045-5201
 1-(800) GRAINGER, 1-(800) 472-4643, (847) 535-1000
 www.grainger.com

This file and any associated information and specifications are provided for reference and evaluation purposes only, and is subject to change without notice. Grainger makes no representations, warranties or guarantees as to the appropriateness, accuracy, completeness, or suitability for any purpose, of the file, information or specifications. You are solely responsible for the use of the file, information or specifications.

This drawing is the property of GRAINGER. It contains confidential, proprietary information that is GRAINGER property. Do not disclose to or duplicate for others except as authorized by GRAINGER.

SCALE 0.389

<h1 style="margin: 0;">4HP59</h1> <p style="margin: 0;">ELECTRIC VIBRATOR, 16A, 12VDC, 1-PHASE</p>
--

UNIT
INCH [MM]
SHEET
1 of 1