

5 AF Hex socket

17 AF Hex.
12 Nm
(9 lb. ft.)
Torque

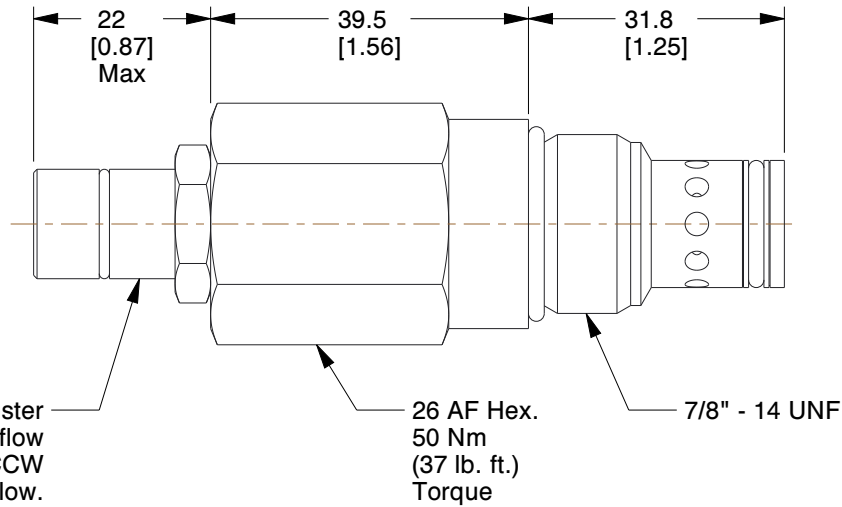

NOTES:

1. ITEM: Cartridge Valve
2. VALVE CAVITY SIZE: C10-2
3. CARTRIDGE VALVE ITEM: Cartridge Valve
4. MAX. FLOW - HYDRAULIC VALVES: 10.6 gpm
5. MAX. PRESSURE - HYDRAULIC VALVES: 6000 psi
6. CARTRIDGE VALVE TYPE: Pressure Compensated Flow Control Restrictive Style
7. APPLICATION: Used to Maintain a Controlled Flow Regardless of Changes in Load or Inlet Pressure

| COMPONENT | | Hydraulic Cartridge Valves | |
|--|--|----------------------------|-----------|
| 4DMK9 | | UNIT | MM (INCH) |
| | | SHEET | 1 of 1 |
| Cartridge Valve, PC Flow Control, 10.6 GPM | | SCALE | 1.06 |



100 Grainger Parkway, Lake Forest, Illinois 60045-5201
1-(800) GRAINGER, 1-(800) 472-4643, (847) 535-1000
www.grainger.com

This file and any associated information and specifications are provided for reference and evaluation purposes only, and is subject to change without notice. Grainger makes no representations, warranties or guarantees as to the appropriateness, accuracy, completeness, or suitability for any purpose, of the file, information or specifications. You are solely responsible for the use of the file, information or specifications.

This drawing is the property of GRAINGER. It contains confidential, proprietary information that is GRAINGER property. Do not disclose to or duplicate for others except as authorized by GRAINGER.