

(2) 5/16-18 UNC x 1/4 Lg.
 (1) over KS & (1) @ 90°
 7 ft-lb Screw Torque Req.

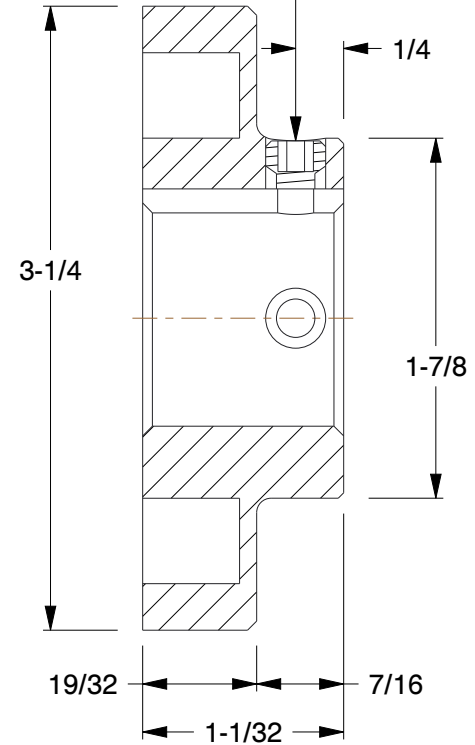

NOTES:

1. WEIGHT: 0.9 Lbs.
2. MAXIMUM RPM: 7,600
3. KEYSEAT: 1/4 in. x 1/8 in.
4. TORQUE RATING: 312 in-lb
5. COMPONENT WR2: 0.0086 lbs-ft2
6. MATERIAL: Sintered Carbon Steel
7. MAX. ANGULAR MISALIGNMENT: 1°
8. MAX. PARALLEL MISALIGNMENT: 0.015 in.
9. MAX. ANGULAR GAP MISALIGNMENT: 0.056 in.

COMPONENT		Sleeve Coupling Flange	
32ZR26		Sure-Flex® Plus	
		Type J, Size 5, BTS Flange	
UNIT		INCH	
SHEET		1 of 1	

GRAINGER
 100 Grainger Parkway, Lake Forest, Illinois 60045-5201
 1-(800) GRAINGER, 1-(800) 472-4643, (847) 535-1000
 www.grainger.com

This file and any associated information and specifications are provided for reference and evaluation purposes only, and is subject to change without notice. Grainger makes no representations, warranties or guarantees as to the appropriateness, accuracy, completeness, or suitability for any purpose, of the file, information or specifications. You are solely responsible for the use of the file, information or specifications.

This drawing is the property of GRAINGER. It contains confidential, proprietary information that is GRAINGER property. Do not disclose to or duplicate for others except as authorized by GRAINGER.

SCALE	1.00
--------------	------