

(2) 1/4-20 UNC x 3/16 Lg.
 (1) over KS & (1) @ 90°
 3 ft-lb Screw Torque Req.

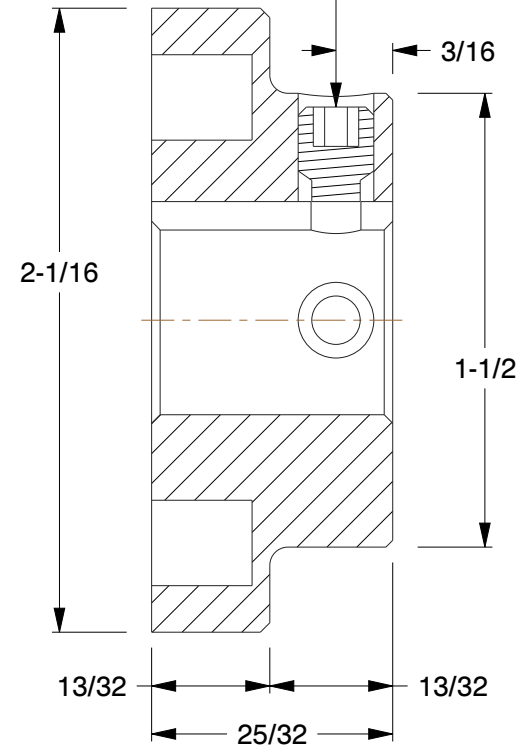

NOTES:

1. WEIGHT: 0.3 Lbs.
2. MAXIMUM RPM: 9,200
3. KEYSEAT: 3/16 in. x 3/32 in.
4. TORQUE RATING: 78 in-lb
5. COMPONENT WR2: 0.0008 lbs-ft²
6. MATERIAL: High Strength Cast Iron
7. MAX. ANGULAR MISALIGNMENT: 1°
8. MAX. PARALLEL MISALIGNMENT: 0.010 in.
9. MAX. ANGULAR GAP MISALIGNMENT: 0.035 in.

COMPONENT		Sleeve Coupling Flange	
<h1>32ZR13</h1> <p>Sure-Flex® Plus Type J, Size 3, BTS Flange</p>		UNIT	INCH
		SHEET	1 of 1

GRAINGER
 100 Grainger Parkway, Lake Forest, Illinois 60045-5201
 1-(800) GRAINGER, 1-(800) 472-4643, (847) 535-1000
 www.grainger.com

This file and any associated information and specifications are provided for reference and evaluation purposes only, and is subject to change without notice. Grainger makes no representations, warranties or guarantees as to the appropriateness, accuracy, completeness, or suitability for any purpose, of the file, information or specifications. You are solely responsible for the use of the file, information or specifications.

This drawing is the property of GRAINGER. It contains confidential, proprietary information that is GRAINGER property. Do not disclose to or duplicate for others except as authorized by GRAINGER.

SCALE 1.00