

Series	Parker ST Series	Max. Pressure	1200 psi
Connection Type	MNPT	Quick Coupler Type	Hydraulic Coupler Body
Coupler Flow Rate	50.0 gpm	Locking Mechanism	Ball
Coupler Body Size	1"	Coupler Body Material	Brass
Coupler Thread Size	1"-11-1/2	Operating Temp. Range	-40° to 250°F

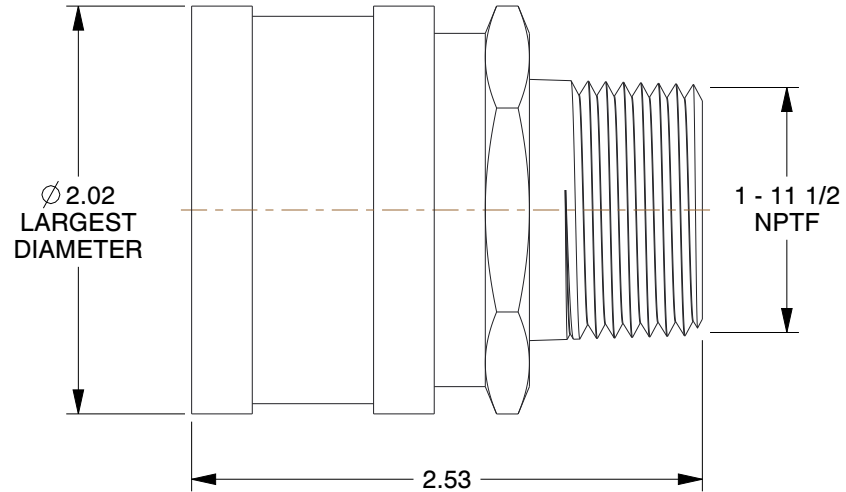
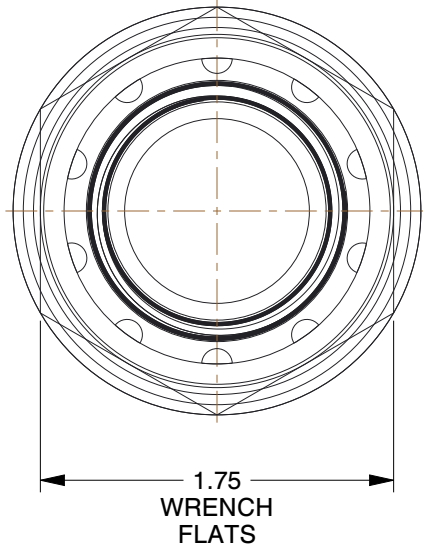

NOTES:

1. SEAL MATERIAL: Buna
2. COUPLER FINISH: Plain
3. SLEEVE MATERIAL: Brass
4. ITEM: Hydraulic Coupler Body
5. FOR USE WITH: Parker ST Series
6. PARKER INTERCHANGE: BST-8M
7. BEARING MATERIAL: Stainless Steel
8. COUPLER INTERCHANGE TYPE: ST

COMPONENT	Hydraulic Quick Couplers
------------------	--------------------------



100 Grainger Parkway, Lake Forest, Illinois 60045-5201
 1-(800) GRAINGER, 1-(800) 472-4643, (847) 535-1000
 www.grainger.com

This file and any associated information and specifications are provided for reference and evaluation purposes only, and is subject to change without notice. Grainger makes no representations, warranties or guarantees as to the appropriateness, accuracy, completeness, or suitability for any purpose, of the file, information or specifications. You are solely responsible for the use of the file, information or specifications.

This drawing is the property of GRAINGER. It contains confidential, proprietary information that is GRAINGER property. Do not disclose to or duplicate for others except as authorized by GRAINGER.

SCALE 1.05

31A963	UNIT
	INCH
	SHEET
	1 of 1

Coupler Body, 1-11-1/2, 1 In. Body, Brass