

Item	Hydraulic Gear Pump	Mounting	SAE AA 2 Bolt
Housing	Aluminum	Ports (Inlet)	7/8-14
Rotation	Right	Ports (Outlet)	3/4-16
Max. RPM	4000	Cover Material	Cast iron
Min. RPM	700	Shaft Extension (In.)	1/2 x 1-1/2 Keyed

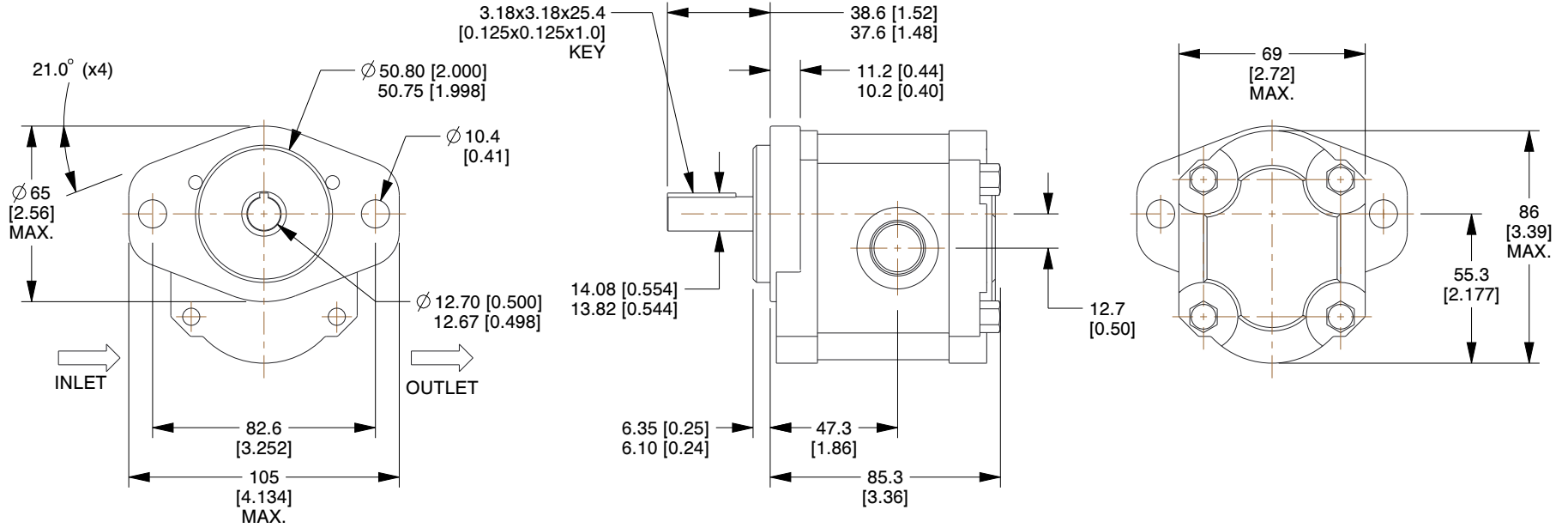

NOTES:

1. MAX. CONTINUOUS PSI: 4000
2. NOMINAL GPM @ 1200 RPM: 1.6
3. GPM @ 1800 RPM & 1000 PSI: 2.2
4. GPM @ 3600 RPM & 1000 PSI: 4.5
5. DISPLACEMENT (CU. IN./REV.): 0.305
6. MAX. INTERMITTENT PRESSURE (PSI): 4000

COMPONENT		Hydraulic Gear Pumps	
1DBC6		UNIT	MM (INCH)
		SHEET	1 of 1
Gear Pump, 0.305 cu in/rev, 4000 PSI Max		SCALE	0.42



100 Grainger Parkway, Lake Forest, Illinois 60045-5201
 1-(800) GRAINGER, 1-(800) 472-4643, (847) 535-1000
 www.grainger.com

This file and any associated information and specifications are provided for reference and evaluation purposes only, and is subject to change without notice. Grainger makes no representations, warranties or guarantees as to the appropriateness, accuracy, completeness, or suitability for any purpose, of the file, information or specifications. You are solely responsible for the use of the file, information or specifications.

This drawing is the property of GRAINGER. It contains confidential, proprietary information that is GRAINGER property. Do not disclose to or duplicate for others except as authorized by GRAINGER.