

Product information presented here reflects conditions at time of publication. Consult factory regarding discrepancies or inconsistencies.



PUMP COMPANY

Zoeller Family of Water Solutions™

MAIL TO: P.O. BOX 16347 • Louisville, KY 40256-0347
SHIP TO: 3649 Cane Run Road • Louisville, KY 40211-1961
(502) 778-2731 • 1 (800) 928-PUMP • FAX (502) 774-3624

visit our web site:
www.zoeller.com

ALARM PANEL for OIL SMART® & OIL GUARD® SYSTEMS INSTALLATION INSTRUCTIONS



⚠ WARNING

1. All installations must be in accordance with the National Electrical Code, and any other applicable state and local electrical requirements.
2. **Do not remove ground pin.** Severe electrical shock could occur.
3. Check with local codes for proper installation.



⚠ WARNING

1. The switch and pump are not rated for explosive environments. This product is intended for hydraulic oils only.

Installation Instructions for 1 1/2" pipe.

1. Review figures 1,2,3,4, and 5.
2. Attach Oil Smart® Liquid Alarm Switch to Quick Mount Bracket using #10 screws and nuts provided (See Figure 1).
3. Snap bracket onto discharge pipe or float tree (See Figure 1).
4. Install Oil Smart® Liquid Alarm Switch at high water level 10" above normal pump "on" level.
5. Place hose clamp on pipe under Quick Mount Bracket (See Figure 1) for reference location of the Oil Smart® Liquid Alarm Switch.
6. For easy maintenance, snap Quick Mount Bracket assembly off and on pipe using the hose clamp as a guide.
7. Mount Oil Smart® Liquid Alarm Switch clear of inlet water at least 1" to 2" away from any metallic material.
8. Mount Alarm Panel and connect to a separate branch GFCI circuit (See Figure 3 or 4).

Installation Instructions other than 1 1/2" pipe.

1. Use the universal PVC bracket and clamp provided.
2. Insert hose clamp through top of bracket (See Figure 2).
3. Mount Oil Smart® Liquid Alarm Switch to universal bracket using #10 screws and nuts provided.
4. Install Oil Smart® Liquid Alarm Switch at high water level 10" above normal pump "on" level using clamp provided.
5. Mount Oil Smart® Liquid Alarm Switch clear of inlet water at least 1" to 2" away from any metallic material.
6. Mount Alarm Panel and connect to a separate branch GFCI circuit (See Figure 3 or 4).

Installation instructions for mounting to basin wall.

Reference FM2364 or FM2104.

For remote Supervisory Control and Data Acquisition (SCADA) (See Figure 5).

TB1:

1. Water - location #8. Normally open
2. Com- location #9.
3. Oil - location #10. Normally open
4. Alarm - location #11. Normally open

Oil Smart® Liquid Alarm Switch Operation

Oil Smart® Liquid Alarm Switch detects high liquid levels and differentiates the presence of oil and water. Activates a red light, audible alarm and oil (yellow) or water (white) indicator light.

Alarm Mode 1 (oil present): If oil is present in the water as the level rises to the Oil Smart® Liquid Alarm Switch, the red and yellow lights will turn on and the alarm will sound.

Alarm Mode 2 (high water): If no oil is present as the level rises to the Oil Smart® Liquid Alarm Switch, the red and white lights will turn on and the alarm will sound.

Testing Oil Smart® Liquid Alarm Switch

- A. Plug alarm panel into electrical outlet (115V).
- B. Fill paper cup with water.
- C. Submerge optical sensor in water (metal probe exposed to air)
- D. Touch a wet paper towel or wet rag to the metal probe. Water indicator light (white), audible and alarm light will turn on. Repeat test using oil.

Maintenance

1. Plastic switch case and metal sensor leads must be kept clean, free of corrosion, mud, soap. Clean switch every four months or as often as environmental conditions dictate.
2. Clean with oil base product like kerosene, solvent or WD40. Do not use soap.

FIGURE 1 Quick Mount Bracket Assembly.

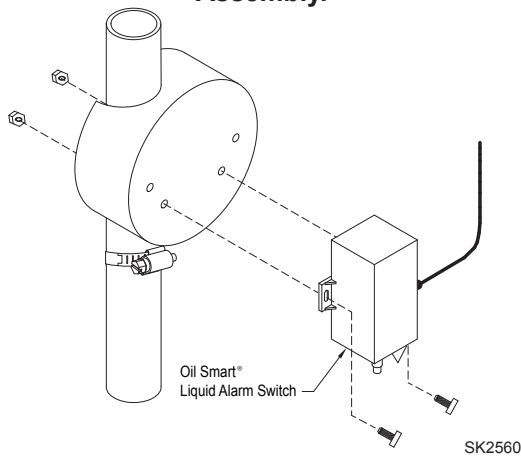

FIGURE 2 Universal PVC Bracket

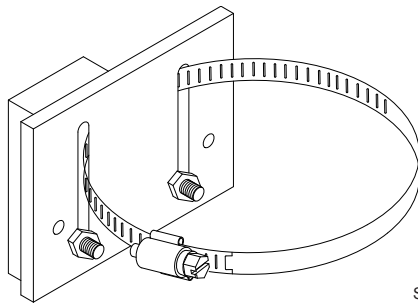
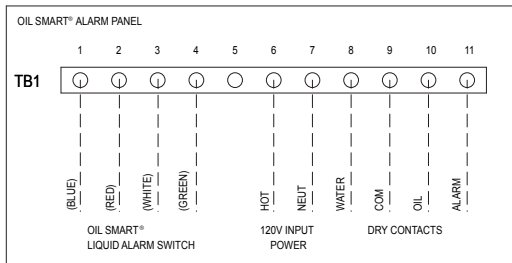

FIGURE 5 OIL SMART® ALARM PANEL WIRING DIAGRAM



Limited Warranty

Manufacturer warrants, to the purchaser and subsequent owner during the warranty period, every new product to be free from defects in material and workmanship under normal use and service, when properly used and maintained, for a period of one year from date of purchase by the end user, or 18 months from date of original manufacture of the product, whichever comes first. Parts that fail within the warranty period, one year from date of purchase by the end user, or 18 months from the date of original manufacture of the product, whichever comes first, that inspections determine to be defective in material or workmanship, will be repaired, replaced or remanufactured at Manufacturer's option, provided however, that by so doing we will not be obligated to replace an entire assembly, the entire mechanism or the complete unit. No allowance will be made for shipping charges, damages, labor or other charges that may occur due to product failure, repair or replacement.

This warranty does not apply to and there shall be no warranty for any material or product that has been disassembled without prior approval of Manufacturer, subjected to misuse, misapplication, neglect, alteration, accident or act of God; that has not been installed, operated or maintained in accordance with Manufacturer's installation instructions; that has been exposed to outside substances including but not limited to the following: sand, gravel, cement, mud, tar, hydrocarbons, hydrocarbon derivatives (oil, gasoline, solvents, etc.), or other abrasive or corrosive substances, wash towels or feminine sanitary products, etc. in all pumping applications. The warranty set out in the paragraph above is in lieu of all other warranties expressed or implied; and we do not authorize any representative or other person to assume for us any other liability in connection with our products.

FIGURE 3 Typical Installation of Oil Smart® Pump Switch and Alarm Panel.

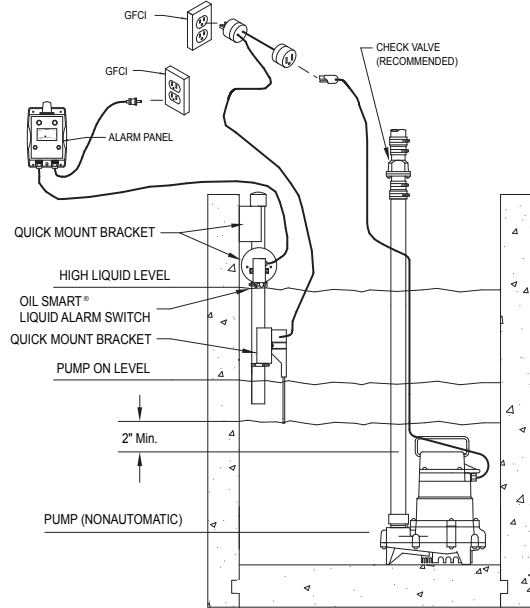
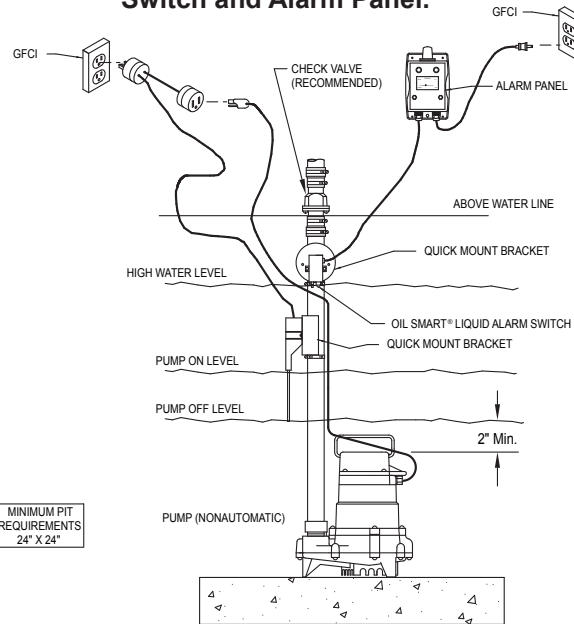

FIGURE 4 Typical Installation of Oil Smart® Pump Switch and Alarm Panel.



Contact Manufacturer at, 3649 Cane Run Road, Louisville, Kentucky 40211, Attention: Customer Service Department to obtain any needed repair or replacement of part(s) or additional information pertaining to our warranty.

MANUFACTURER EXPRESSLY DISCLAIMS LIABILITY FOR SPECIAL, CONSEQUENTIAL OR INCIDENTAL DAMAGES OR BREACH OF EXPRESSED OR IMPLIED WARRANTY; AND ANY IMPLIED WARRANTY OF FITNESS FOR A PARTICULAR PURPOSE AND OF MERCHANTABILITY SHALL BE LIMITED TO THE DURATION OF THE EXPRESSED WARRANTY.

Some states do not allow limitations on the duration of an implied warranty, so the above limitation may not apply to you. Some states do not allow the exclusion or limitation of incidental or consequential damages, so the above limitation or exclusion may not apply to you.

This warranty gives you specific legal rights and you may also have other rights which vary from state to state.

In those instances where damages are incurred as a result of an alleged pump failure, the Homeowner must retain possession of the pump for investigation purposes.