

ASSEMBLY AND INSTALLATION INSTRUCTIONS

Transfer Tank - Models 350-3-01, 352-3-01, 354-3-01 358-3-01 and 360-3-01

IMPORTANT BEFORE YOU BEGIN

Read these instructions and warnings completely before installation.

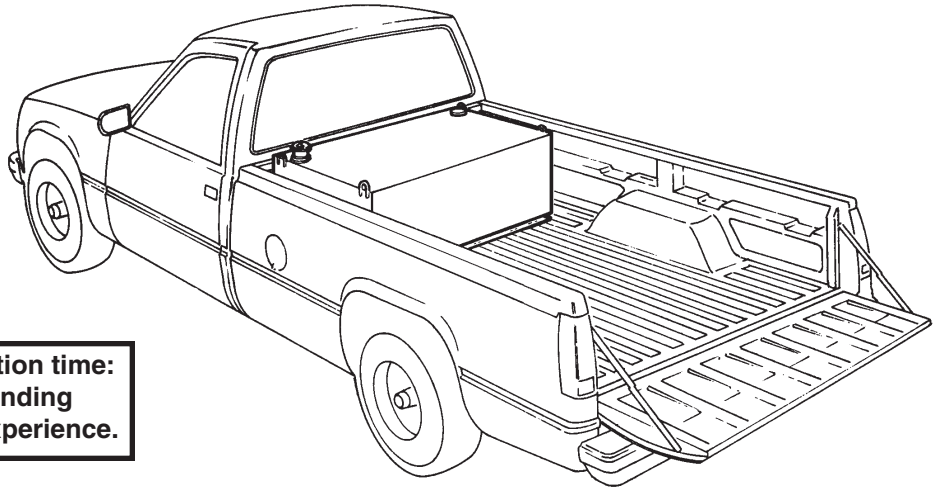

Approximate Assembly & Installation time:
54 min. per unit (0.9 hrs.) depending
on truck equipment installation experience.



DANGER

Use of flammables in this transfer tank may cause an explosion, resulting in serious bodily injury, death, or property damage.

To avoid such risk:

- DO NOT Use this transfer tank to transport, transfer or store flammables, such as gasoline;
- DO NOT Use this transfer tank as an auxiliary fuel tank by connecting it to an existing fuel system;
- DO NOT Use this transfer tank for fueling aircraft;
- DO NOT Modify this transfer tank in any way or use it for any purpose other than its intended use.
- DO Use this transfer tank only for the transport, transfer or storage of diesel fuel only.
- DO Use this transfer tank only in fueling land-based motor vehicles and equipment;
- DO Vent this transfer tank at all times to allow for fuel expansion and to prevent vacuum during fluid or fuel removal.

NOTE:

This transfer tank does not comply with the following specifications:

- Title 49 of the Code of Federal Regulations for the interstate transfer of flammables, explosives, hazardous materials and hazardous wastes.
- Underwriters' Laboratories of Canada C142.13 requirements for transportation of flammables and combustible liquids.

These tanks may also be subject to individual state or province regulations, compliance with which is the responsibility of the owner.

weather guard

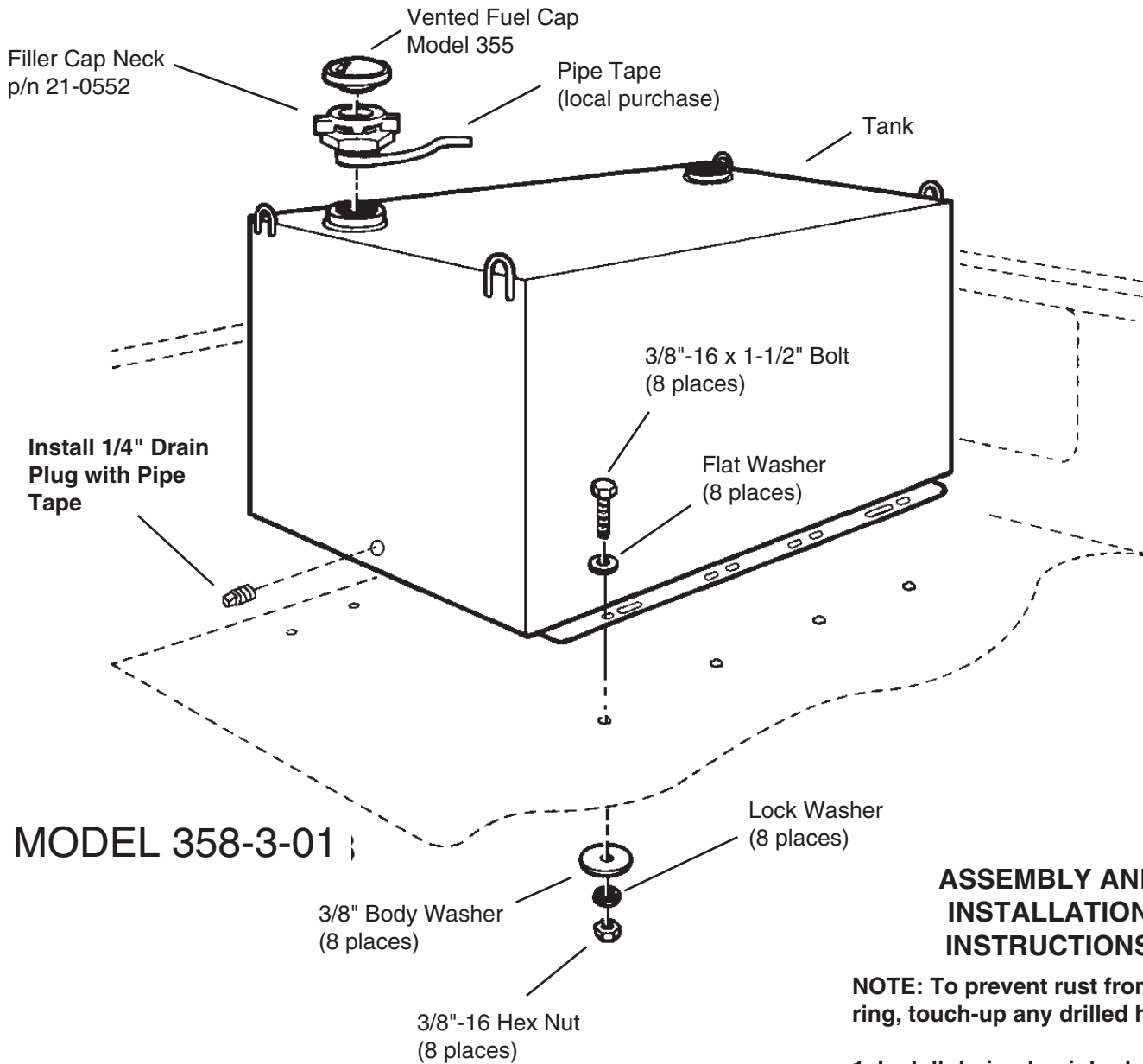

MODEL 358-3-01 ;

ASSEMBLY AND INSTALLATION INSTRUCTIONS

NOTE: To prevent rust from occurring, touch-up any drilled holes.

1. Install drain plug into drain hole.
2. When installing model 352 Transfer Tank with a 27" tool box in a full size short bed pickup, the Tank will need to be mounted with filler openings toward center of the bed to avoid tool box hitting wheel wells. Except full size short wheel base Dodge pickup, where a 27" wide box will not fit.

PARTS LIST

- Transfer Tank
- Filler Cap Neck
- Filler Cap
- Bolt Kit

BOLT KIT

Bolt kit #32-0350 is provided with your tank. Check this bolt kit to be sure the following items are included:

TOOLS REQUIRED

- Electric Drill with 7/16" Drill Bit
- 9/16" Open or Box End Wrench (2)
- Pipe Wrench
- Pipe Tape

| Qty. | Description |
|------|--------------------------|
| 8 | 3/8-16 x 1-1/2" Hex Bolt |
| 8 | 3/8-16 Hex Nut |
| 8 | 3/8" Flat Washer |
| 8 | 3/8" Lock Washer |
| 8 | 3/8" Body Washer |
| 1 | 1/4" Drain Plug |
| 6 | Floor Spacer |

⚠ CAUTION

Transfer Tank bottom must be fully supported by the floor of the truck bed so as not to cause flexing of the tank which could cause stress cracks and leakage of the tank.

3. Center the tank evenly between the bed sides and mark eight mounting holes. For the "L" shaped tanks, mark both holes of the side mounting angles, as well as four evenly spaced holes of the longer front mounting angle. For the Model 358, mark four holes evenly spaced in each mounting angle.

WARNING

All floor mounting bolts near the gas tank area should be installed from the underside of the vehicle, to guard against the gas tank being punctured in the event of a collision.

CAUTION

To keep debris out of your eyes when checking the underside of the vehicle, or when drilling, always wear protective eyewear.

WARNING

Prior to drilling, so as not to cut or puncture fuel tanks, fuel lines, brake lines, electric wires, etc., check under vehicle for locations.

4. Remove the tank and drill the marked hole locations with a 7/16" drill bit.

NOTE: If any drilled holes fall between the ribs on the lower part of the floor, it will be necessary to use Floor Spacers between the Tank mounting angle and the floor.

5. Replace tank and bolt securely.

6. Before installing Filler Cap Neck, wrap threaded end with Pipe tape. Do not use liquid or paste Plumber's pipe dope. Install the filler cap neck, using a pipe wrench to tighten.

7. Install Vented Fuel Cap.

NOTE: Use Pipe Tape when using a manual or electric transfer pump on the tank.

NOTE: Transfer tank and pump must be grounded to prevent static charge build-up.

NOTE:

When warning decals cannot be read or when they do not stay affixed to this transfer tank, the owner of this product is legally responsible for replacing these warning decals for free by contacting: Knaack LLC at 420 E. Terra Cotta Ave., Crystal Lake, IL, 60014 or call 1-800-456-7865 for free replacements.

- NOTICE -

Any modification or unintended use of this product shall immediately void all manufacturer's warranties. Manufacturer disclaims all liability for injuries to persons or property resulting from any modification to, or unintended use of this product.

FUTURE TRANSFER TANK REMOVAL

Empty all of the combustible liquid and use all lifting hooks for safe and controlled removal of transfer tank from the vehicle.

WEATHER GUARD® PRODUCT REFINISHING PROCEDURES

All WEATHER GUARD® products are finished with a polyester powder coating, and it is important to follow these procedures to get proper adhesion. As Knaack LLC cannot control the finishing of the products, the warranty for WEATHER GUARD® products on paint is not applicable on refinished products.

1. Sand the surface to be painted with 180-200 grit sand paper to rough up the surface. This should be followed by wet sanding with a 400 grit wet or dry paper.

2. Wipe down the sanded surface with ketone based thinner. This removes the dust and softens the powder coating for better paint adhesion.

3. Wipe sanded area with a tack rag to remove loose dust and particles before painting.

NOTE: Do not use a lacquer over the powdered coating.

DANGER

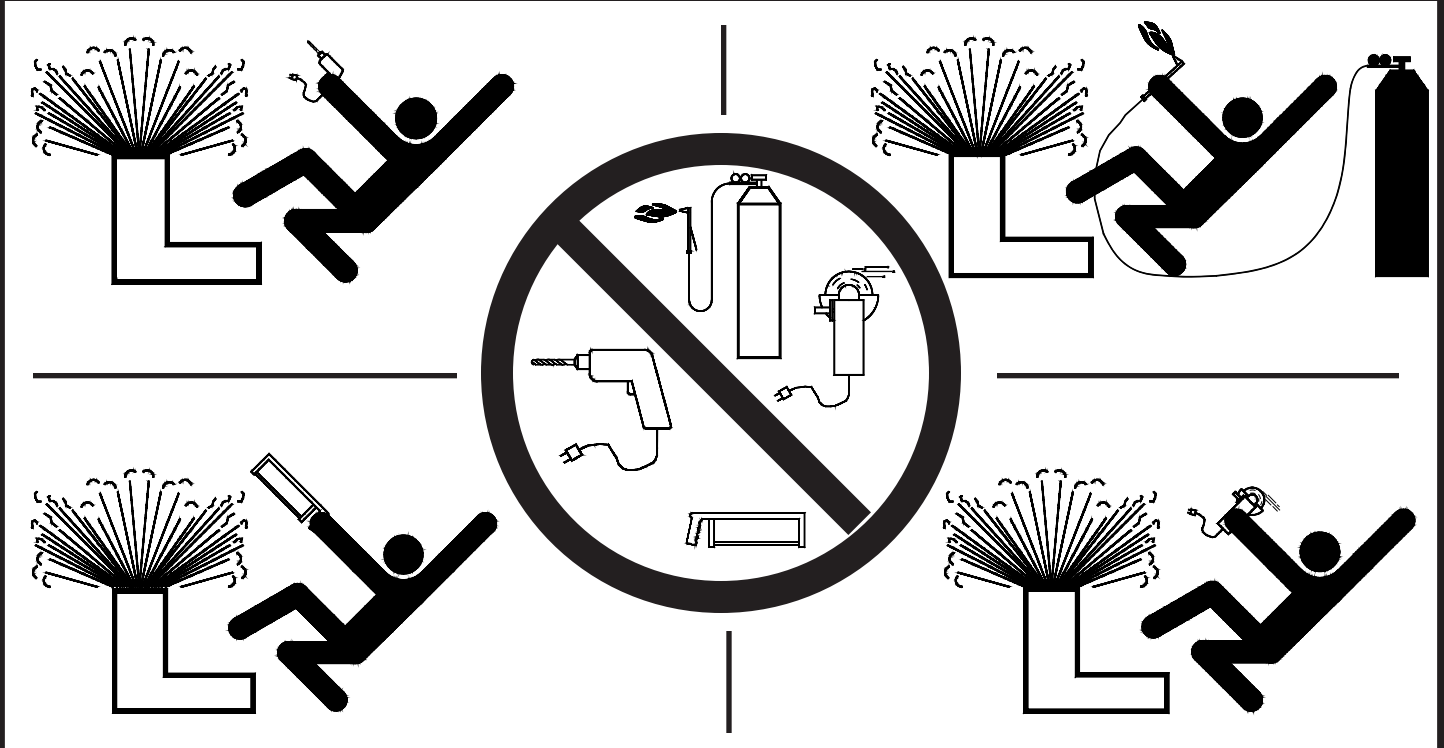

Danger of explosion. Do not drill, grind, saw, weld or use a torch on this product. Doing so could result in serious injury, death or property damage.

WEATHER GUARD® products are protected by one or more of the following patents or trademarks:
U.S. - 842268, 1661625, 1663369, 2228051, 2362167; Canada - 282725, 72467, 428587, 1235100, 1218968; U.K. - 1400720; N.Z. - 296049
other patents and trademarks pending.

Knaack LLC

ATTN: Warranty Claims
420 E. Terra Cotta Avenue
Crystal Lake, IL 60014

If you have any questions, please call toll free at 1-800-456-7865.
©2013 Knaack LLC

