

ALUMINUM TRUCK DOCKBOARD WITH STEEL SAFETY CURB - TAS-10-6048

APPROX WEIGHT: 134.11 lbs.
 DOES NOT INCLUDE WEIGHT OF POWER OR PACKAGING!!!

*** ANY ADDITIONS, DELETIONS, OR OMISSIONS MUST BE CORRECTED ON THIS DRAWING AS THIS DRAWING WILL BE CONSIDERED ALL INCLUSIVE ***
 ALL GRAPHICS PROVIDED ARE FOR REFERENCE ONLY. IF CERTAIN DIMENSIONS ARE CRITICAL PLEASE VERIFY THOSE DIMENSIONS WITH YOUR SALESPERSON

LEGS: RIGHT LEG IS 9", LEFT LEG IS 8". LEGS ARE UNEVEN TO
 CREATE A GAP SO DOCKBOARD CAN BE PICKED UP BY A FORK LIFT

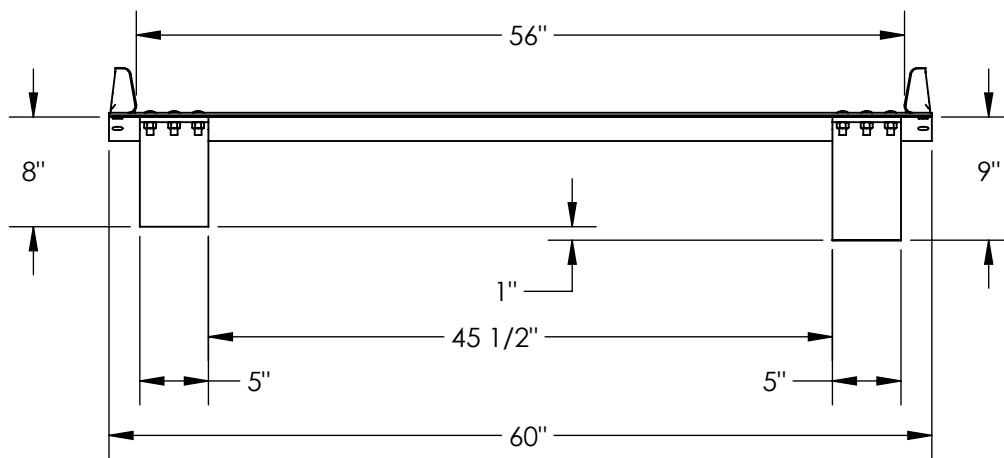
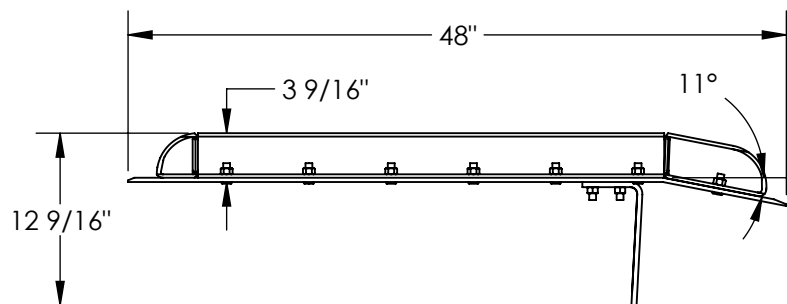
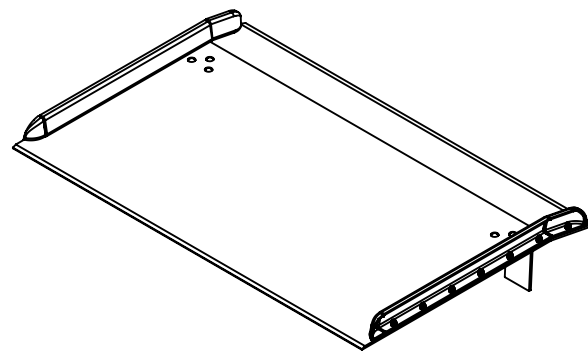

STANDARD FEATURES

- MODEL NUMBER IS: TAS-10-6048
- OVERALL WIDTH IS: 60"
- USABLE WIDTH IS: 56"
- OVERALL LENGTH IS: 48"
- USABLE LENGTH IS: 48"
- OVERALL HEIGHT IS: 12 9/16"
- MAX CAPACITY IS: 10,000 LBS

SPECIAL FEATURES

NONE

APPROVAL	I, THE UNDERSIGNED, AGREE THAT THE PRODUCT AS REPRESENTED SATISFIES DESIGN AND DIMENSION REQUIREMENTS. I ALSO ACKNOWLEDGE MY DUTY TO CONFIRM PRODUCT AND INSTALLATION COMPLIANCE WITH ALL APPLICABLE FEDERAL, STATE AND LOCAL REGULATIONS AND STANDARDS.	
	ALL SPECIAL UNITS ARE NON-RETURNABLE <input type="checkbox"/> As drawn <input type="checkbox"/> As marked	
	Signed: _____	Date: _____
	LEAD TIME WILL START UPON RECEIPT OF SIGNED APPROVAL DRAWING	

DISTRIBUTOR'S NAME:		P.O.#
VESTIL MANUFACTURING		X
DRAWN BY: MTS		W.O.#
DATE: 09/11/2014		X
REFERENCE: X	SCALE: 1:14	SALES: X
QUOTED LEAD TIME: X	QUOTE # X	FILE NAME:
		11-007-033