

HI-DUTY/HI-FRAME STOCKPICKER TRUCK - SPS-HD-2252

APPROX WEIGHT: 182.92 lbs.
DOES NOT INCLUDE WEIGHT OF POWER OR PACKAGING!!!

*** ANY ADDITIONS, DELETIONS, OR OMISSIONS MUST BE CORRECTED ON THIS DRAWING AS THIS DRAWING WILL BE CONSIDERED ALL INCLUSIVE ***
ALL GRAPHICS PROVIDED ARE FOR REFERENCE ONLY. IF CERTAIN DIMENSIONS ARE CRITICAL PLEASE VERIFY THOSE DIMENSIONS WITH YOUR SALESPERSON

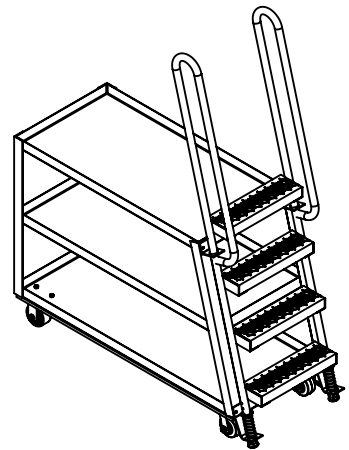
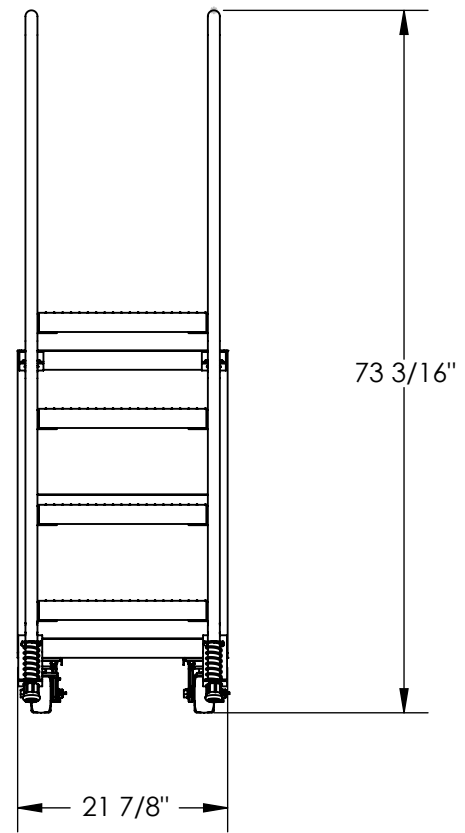
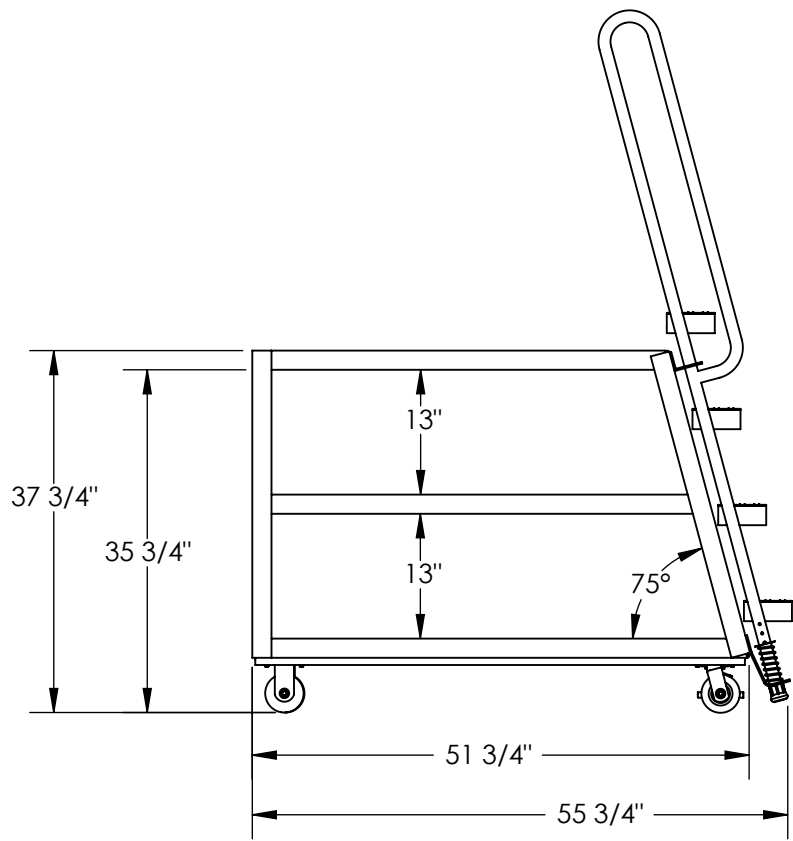

ISOMETRIC VIEW
SCALE: 1:32

STANDARD FEATURES

- MODEL NUMBER: SPS-HD-2252
- OVERALL WIDTH: 21 7/8"
- OVERALL LENGTH: 55 3/4"
- OVERALL HEIGHT: 73 3/16"
- BOTTOM SHELF SIZE: 21 5/8" X 51 5/8"
- TOP SHELF SIZE: 21 5/8" X 43 5/8"
- TOP SHELF HEIGHT: 35 3/4"
- SHELF CLEARANCE: 13"
- 4 X 2 MOLD-ON-RUBBER CASTERS:
TWO SWIVEL, TWO RIGID
- STEEL FRAME CONSTRUCTION
- MAX CAPACITY: 1,000LBS. (500LBS PER SHELF)
- POWDER COATED BLUE FINISH

SPECIAL FEATURES

NONE

A P P R O V A L	I, THE UNDERSIGNED, AGREE THAT THE PRODUCT AS REPRESENTED SATISFIES DESIGN AND DIMENSION REQUIREMENTS. I ALSO ACKNOWLEDGE MY DUTY TO CONFIRM PRODUCT AND INSTALLATION COMPLIANCE WITH ALL APPLICABLE FEDERAL, STATE AND LOCAL REGULATIONS AND STANDARDS.	
	ALL SPECIAL UNITS ARE NON-RETURNABLE	
	[] As drawn [] As marked	
Signed: _____		Date: _____
LEAD TIME WILL START UPON RECEIPT OF SIGNED APPROVAL DRAWING		

DISTRIBUTOR'S NAME:		P.O.#
VESTIL MANUFACTURING		X
DRAWN BY: X		W.O.#
DATE: XX/XX/XX		X
REFERENCE: X	SCALE: 1:20	SALES: X
QUOTED LEAD TIME: X	QUOTE # X	FILE NAME:
		32-007-036