

TBM6 and TBM6S Compression Tool Instructions

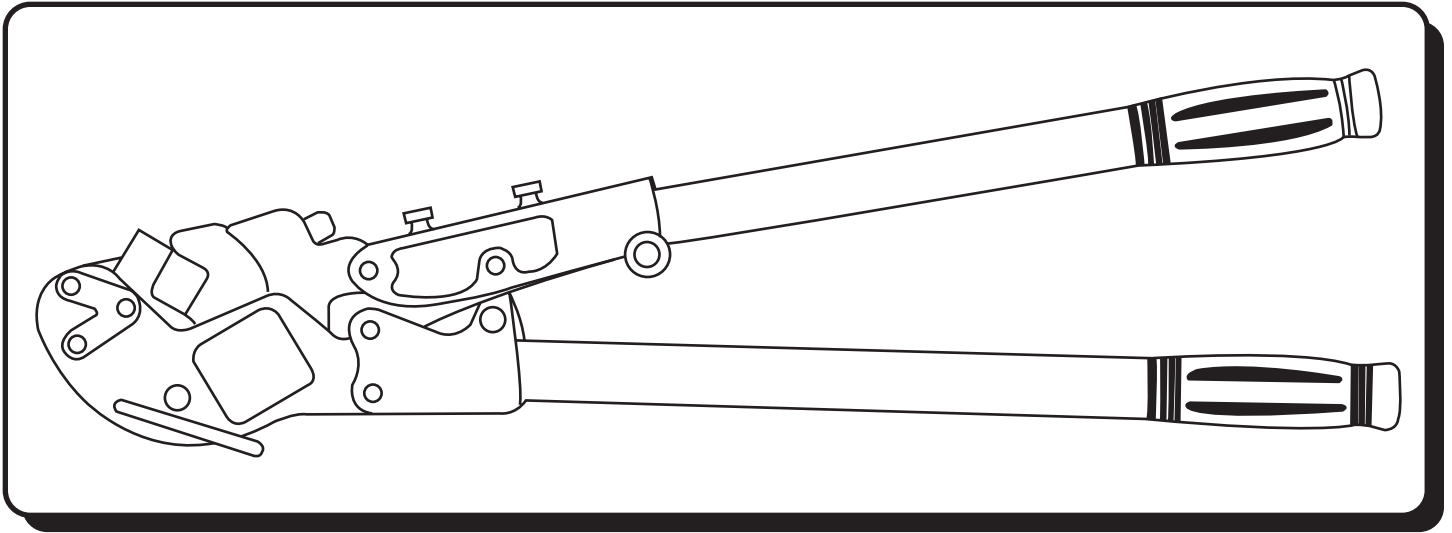

 Read and understand all of the instructions and safety information in this manual before operating or servicing this tool.

Table of Contents

1.0 Operating Instructions	2
1.1 Tool Description	2
1.2 Die Description	2
1.3 Choosing The Die Nest (Sta-Kon®).	2
1.4 Choosing The Die Nest (Color-Keyed®).	2
1.5 Removing, Installing, and Changing Dies	3
1.6 Preparing the Conductor	3
1.7 Making a Compression	3
2.0 Installation Test Procedure.	4
2.1 Installation Test Procedure	4
2.2 Tensile Test Procedure	4
3.0 Calibration Verification.	5
3.1 Visual Inspection	5
3.2 Handle Spread Check	5
3.3 Gaging Procedure	5
3.4 Color-Keyed® Gaging Table	6
3.5 Sta-Kon® Gaging Table	6

1.0

OPERATING INSTRUCTIONS

WARNING

Keep fingers clear of die nests whenever handles are brought together.

WARNING

SHURE STAKE® SAFETY RELEASE

The TBM6S compression tool is equipped with the Shure Stake® full stroke compelling mechanism. If it becomes necessary to release the Shure Stake® Mechanism before completion of the crimp cycle, disengage ratchet as follows. Slightly squeeze handles, and push the dowel pin, releasing the locking mechanism allowing the handles to open.

1.1 TOOL DESCRIPTION

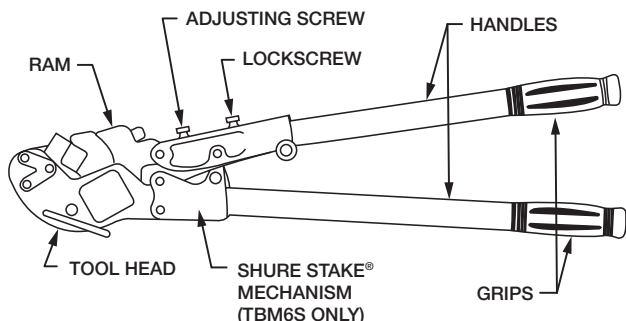

SHURE STAKE® MECHANISM IS DESIGNED TO PROVIDE COMPLETE CLOSURE.

1.2 DIE DESCRIPTION

COLOR-KEYED® DIES

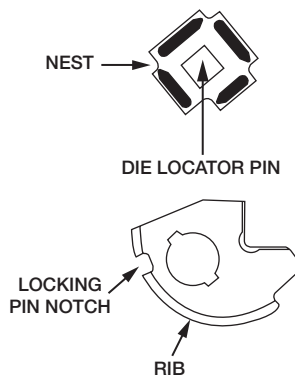

STA-KON® DIES

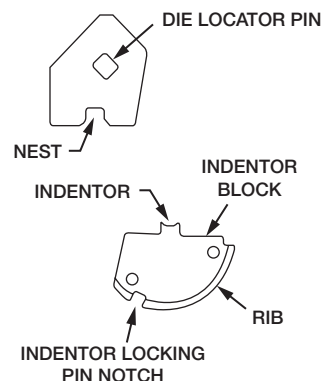

CAUTION

Use only a listed (UL and/or CSA) Thomas & Betts connector with this tool. Any other combination may result in a connection which does not meet established standards.

1.3 CHOOSING THE DIE NEST (STA-KON®)

DESCRIPTION	SIZE	TYPE	DIE CAT. NO.	
			NEST (UPPER)	INDENTOR (LOWER)
NON-INSULATED TERMINALS & SPLICES	D	TUBULAR	11803	11802
		BRAZED		
	E	TUBULAR	11805	
		BRAZED		
	F	TUBULAR	11806	
		BRAZED		
	G	TUBULAR	11806	
	H	TUBULAR	11807	
	J	TUBULAR	11808	
K	TUBULAR	11809		
L	TUBULAR	11810		
M	TUBULAR	11811		
INSULATED TERMINALS & SPLICES	RD	TUBULAR	11821 (SET)	
		BRAZED	11822 (SET)	
	RE	TUBULAR	11823 (SET)	
		BRAZED	11824 (SET)	
	RF	TUBULAR	11824 (SET)	
	RG	TUBULAR	11825 (SET)	
	RH	TUBULAR	11826 (SET)	
	RJ	TUBULAR	11827 (SET)	
	RK	TUBULAR	11828 (SET)	
	RL	TUBULAR	11829 (SET)	
RM	TUBULAR	11829 (SET)		

1.4 CHOOSING THE DIE NEST (COLOR-KEYED®)

Match color on connector to the color on the die. Reference chart.

NOTE: A crimping nest with more than one color band may be used to crimp Color-Keyed® connectors matching any of the nest color bands.

COLOR-KEYED® CONNECTORS

UPPER DIE	UPPER DIE NEST COLORS	USED WITH LOWER DIE CAT. NO.
13478 (1 NEST)	BROWN	13478
13472 (2 NEST)	BLUE & RED GRAY	13476
13474 (4 NEST)	GREEN BLACK & GOLD BROWN ORANGE & TAN	13477
13475 (4 NEST)	RED BLUE PINK PURPLE & OLIVE	13477

COLOR-KEYED® "H" TAPS

"H" TAP CAT. NO.	UPPER DIE CAT. NO.	LOWER DIE CAT. NO.	COLOR CODE
63105	13474	13477	ORANGE
63110	13470	13470	GREEN
63118	13470	13470	GREEN
63125	13470	13470	GREEN
63140	13471	13471	BLUE

1.5

REMOVING, INSTALLING, AND CHANGING DIES

REMOVING DIES

Open handles of tool until fully extended. Pull locking pin all the way down, disengaging it from the lower die. Slip the die along the groove until out of tool. Pull upper die out from under the die retaining spring thus removing it from the tool.

INSTALLING OR CHANGING DIES

Hold tool with die retaining spring facing you and open handles of tool until they are fully extended. Insert the upper die first. Hold the upper die with the desired crimping nest facing toward ram. Insert the upper die under the die retaining spring in the tool head. The die retaining spring will hold the die by pressure on the die locator pin.

Hold the lower die with the rib down and the locking pin notch to the right. Slip rib of lower die into groove in ram. Push the lower die into ram until the die is properly seated and the locking pin snaps into the notch.

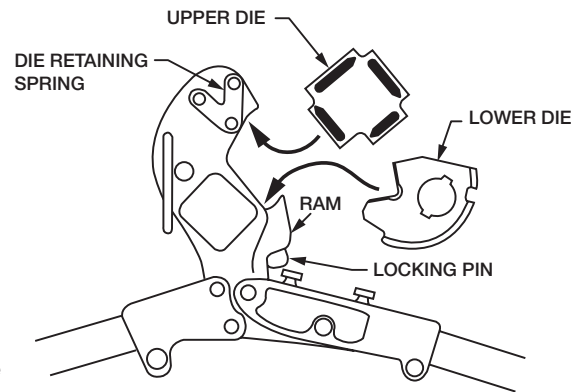

1.6

PREPARING CONDUCTOR

1. Strip insulation properly without cutting or nicking the conductor strands. Refer to the instruction sheet supplied with the connectors regarding strip length.
2. For aluminum cable, smear a thin layer of joint compound onto the cable and brush it in with a wire brush or emery cloth.

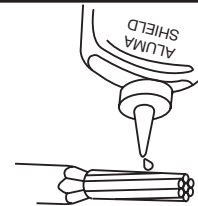

1.7

MAKING A COMPRESSION

1. Insert prepared conductor into connector.
2. **Color-Keyed®** - Locate connector in die grooves of the tool so the die is between the color code marks for copper and on the color code marks for aluminum, see Steps 1, 2 and 3.
Sta-Kon® - Locate terminal in die grooves of the tool so the die is centrally located over barrel of the terminal.
3. Some Color Keyed® connectors require more than one compression. Refer to the instruction sheet supplied with the connectors regarding the number of compressions required. If more than one compression is indicated, the first compression should be in the indicated area nearest to the tongue of a terminal and nearest the center of a splice, and then working progressively toward the end of the barrel.
4. Close handles of tool completely for each compression.

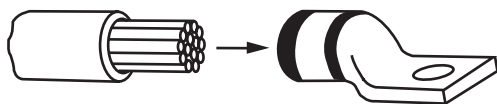

STEP 1

TYPICAL COPPER INSTALLATION

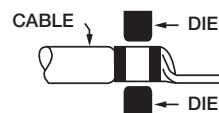

TYPICAL ALUMINUM INSTALLATION

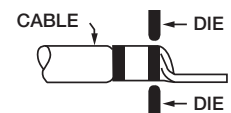

STEP 2

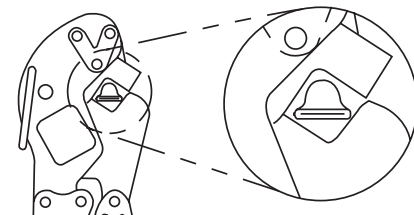

STEP 3

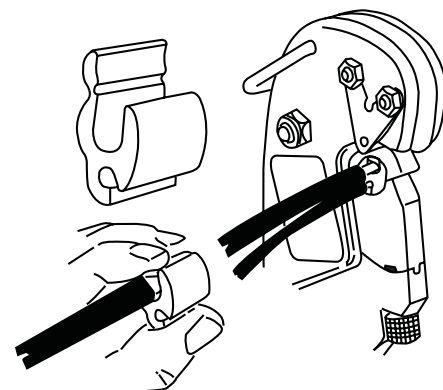

2.0 INSTALLATION TEST PROCEDURE (TBM6S ONLY)

⚠ WARNING ⚠

SHURE STAKE® SAFETY RELEASE The TBM6S compression tool is equipped with the Shure Stake® full stroke compelling mechanism. If it becomes necessary to release the Shure Stake® Mechanism before completion of the crimp cycle, disengage ratchet as follows. Slightly squeeze handles, and push the dowel pin, releasing the locking mechanism allowing the handles to open.

2.1 INSTALLATION TEST PROCEDURE

Using a tool that has passed the calibration requirements install a minimum of six (6) terminals for each die nest on the appropriate wire for which a performance check is required. In order to obtain valid and consistent results, perform installation procedure as follows:

1. Strip conductor approximately 1/4" longer than the connector barrel. (Strip length for test purposes only. For actual installation, refer to the instruction sheet supplied with the connectors.)

⚠ CAUTION ⚠

Care should be taken to strip the insulation of the conductor without cutting or nicking the conductor strands, as this condition will result in premature pull-test failures.

2. For aluminum conductor, smear a thin layer of joint compound onto the cable and brush it in with a wire brush or emery cloth.
3. Insert stripped conductor into connector barrel until it bottoms out.
4. Choose an installing die with the same color marking as the connector.
5. **Color-Keyed®** - Locate connector in die grooves of tool, so that die is between the color code marks for copper and on the color code marks for aluminium, see graphics below.

Sta-Kon® - Locate terminal in die grooves of the tool so the die is centrally located over barrel of the terminal.

6. Some Color Keyed® connectors require more than one compression. Refer to the instruction sheet supplied with the connectors regarding the number of compressions required. If more than one compression is indicated, the first compression should be in the indicated area nearest to the tongue of a terminal and nearest the center of a splice, and then working progressively toward the end of the barrel.
7. Squeeze handles fully closed until SHURE STAKE® mechanism releases.

TYPICAL COPPER INSTALLATION

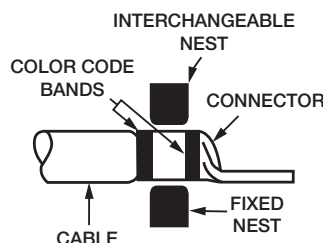

TYPICAL ALUMINUM INSTALLATION

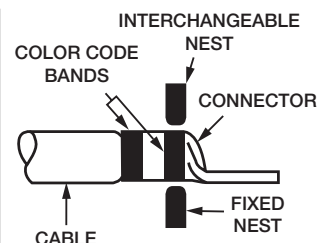

2.2 TENSILE TEST PROCEDURE

1. Install test sample in a tension-testing machine or a suitable pull-test fixture.

NOTE: The pull is to be exerted gradually. An abrupt pull is not a proper test method.

2. Subject each sample to an axial pull which is to be increased until failure of the connection occurs. See graphics below.
3. The pull force required to separate a terminal from its associated wire shall be no less than the minimum pullout (see table on the right).

NOTE: On "C" tap and wire joints, only the smallest wire in each combination is to be tested for pullout.

EXAMPLES OF TENSILE TESTING MACHINES

1. Ametek Testing Equipment Systems, E. Moline, IL 61244. Mechanical Force Gage Model No. D-150M, Testing Stand Model No. CTM.
2. John Chatillion & Sons, Kew Gardens, N.Y., N.Y. 11415. Gage Model No. DPPH-100 or DPPH-200, Testing Stand Model No. HTC.

CABLE SIZE	MIN. PULL-OUT (lbs.*)	
	COPPER	ALUMINUM
12	70	35
10	80	40
8	90	45
6	100	50
4	140	70
2	180	90
1	200	100
1/0	250	125
2/0	300	150
3/0	350	175
4/0	450	225
250	500	250
300	550	275
350	600	300
400	650	325
500	800	400

*Conforms to UL and CSA requirements

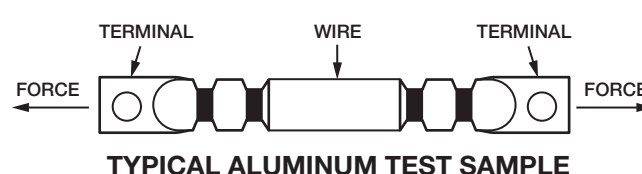
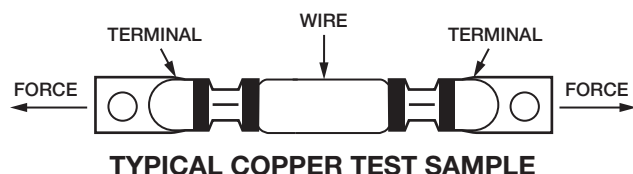

3.0

CALIBRATION VERIFICATION

NOTE: Calibration verification of the tool is mandatory when switching between 13400 Color-Keyed® and 11800 Sta-Kon® series dies. Otherwise, it should be performed whenever damage or suspected damage has occurred or as often as operating conditions warrant.

3.1

VISUAL INSPECTION

1. Tool must be free of cracks, sharp edges and other obvious imperfections that may affect performance of the tool. Nest area must be free of burrs, dents or scratches.

3.2

HANDLE SPREAD CHECK

To ensure the tool will produce a reliable compression, the tool must be properly adjusted. Tool adjustment is mandatory when switching between 13400 Color-Keyed® and 11800 series Sta-Kon® dies.

CHECKING TOOL ADJUSTMENT

1. Insert upper and lower dies in place.
2. Lay tool on a flat surface, open handle **A** and allow it to close under its own weight. The dies should be touching.
3. Measure distance between handle grips. In a properly adjusted tool, the distance should be between 11" and 14". If it is less than 11" or more than 14", the tool needs adjustment. (See graphic below).

ADJUSTING TOOL

1. Loosen lock screw.
2. To increase distance between handles, turn adjusting screw clockwise.
3. To decrease distance between handles, turn adjusting screw counterclockwise.
4. Tighten lock screw.
5. Recheck handle distance. Adjust again, if necessary.

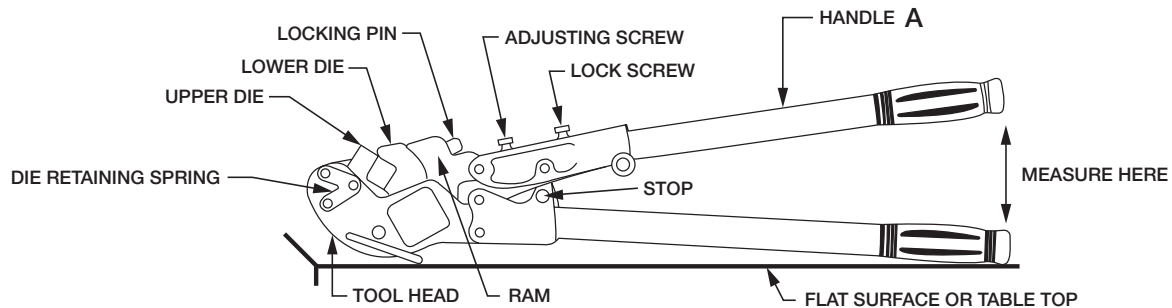

3.3

GAGING PROCEDURE

NOTE: Wipe dies before gaging.

1. Squeeze handles until jaws are fully closed.
2. Select gage pin which can be inserted into nest with minimal hand pressure, see graphic below.
3. Gage pin should fall between the limits shown on tables in section 3.4 & 3.5.

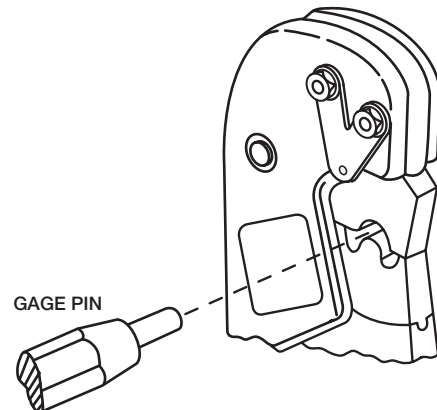

3.4 COLOR-KEYED® GAGING

CONNECTORS AND "H"-TAPS 13400 SERIES DIES

GROOVE COLOR	CAT. NO. UPPER DIE	CAT. NO. LOWER DIE	GAGING MIN. - MAX.
RED	13475	13477	.168 - .177
BLUE	13475	13477	.181 - .201
GRAY	13472	13476	.264 - .276
BROWN	13474	13477	.307 - .321
GREEN	13474	13477	.345 - .359
PINK	13475	13477	.383 - .398
BLACK	13474	13477	.408 - .423
ORANGE	13474	13477	.469 - .487
PRUPLE	13475	13477	.524 - .539
YELLOW	13473	13476	.555 - .575
GOLD	13474	13477	.408 - .423
TAN	13474	13477	.469 - .487
OLIVE	13475	13477	.524 - .539
RUBY	13473	13476	.555 - .575
WHITE	13473	13476	.622 - .637
RED	13472	13476	.704 - .720
BLUE	13472	13476	.704 - .720
GREEN	13470	13470	.808 - .832
BLUE	13471	13471	1.178 - 1.202

NOTE: If tool can not be calibrated, do not attempt repair or adjustment. Call nearest T&B tool service center to arrange for repair service. Any change, modification or alteration of the tool or use by the customer in a manner other than as specified by T&B shall void all warranties express or implied and the customer shall, therefore, assume all liability for any damage or injury caused by said changed, modified or altered tool or improper usage of such tool.

WARRANTY: Thomas & Betts sells this product with the understanding that the user will perform all necessary tests to determine the suitability of this product for the user's intended application. Thomas & Betts warrants that this product will be free from defects in materials and workmanship for the period stated on the enclosed warranty card. Upon prompt notification of any warranted defect, Thomas & Betts will, at its option, repair or replace the defective product or refund the purchase price. Proof of purchase is required. Misuse or unauthorized modification of the product voids all warranties.

Limitations and Exclusions: THE ABOVE WARRANTY IS THE SOLE WARRANTY CONCERNING THIS PRODUCT, AND IS IN LIEU OF ALL OTHER WARRANTIES EXPRESS OR IMPLIED, INCLUDING BUT NOT LIMITED TO ANY IMPLIED WARRANTY OF MERCHANTABILITY OR FITNESS FOR A PARTICULAR PURPOSE, WHICH ARE SPECIFICALLY DISCLAIMED. LIABILITY FOR BREACH OF THE ABOVE WARRANTY IS LIMITED TO COST OF REPAIR OR REPLACEMENT OF THE PRODUCT, AND UNDER NO CIRCUMSTANCES WILL THOMAS & BETTS BE LIABLE FOR ANY INDIRECT, SPECIAL, INCIDENTAL OR CONSEQUENTIAL DAMAGES.

3.5 STA-KON® GAGING

TERMINALS AND SPLICES 11800 SERIES DIES

TERM SIZE	TERM TYPE	WIRE TYPE	DIE CAT. NO.		GAGING ±.010				
			NEST (STATIONARY)	INDENTOR (MOVEABLE)					
D	TUBULAR	AIRCRAFT	11803	11802	.152				
	TUBULAR	CODE							
	BRAZED	CODE							
E	TUBULAR	AIRCRAFT	11805		11802	.167			
	TUBULAR	CODE							
	BRAZED	CODE							
F	TUBULAR	AIRCRAFT	11806			11802	.206		
	TUBULAR	CODE							
	BRAZED	CODE							
G	TUBULAR	AIRCRAFT	11807				11802	.234	
		CODE							
H	TUBULAR	AIRCRAFT	11808	11802				.272	
		CODE							
J	TUBULAR	AIRCRAFT	11809					11802	.250
		CODE							
K	TUBULAR	AIRCRAFT	11810		11802				.266
		CODE							
L	TUBULAR	AIRCRAFT	11811			11802			.312
		CODE							
M	TUBULAR	AIRCRAFT	11811						11802
		CODE							
		CODE							
RD	TUBULAR	AIRCRAFT	11821 (SET)	11802			.170		
	TUBULAR	CODE							
	BRAZED	CODE							
RE	TUBULAR	AIRCRAFT	11822 (SET)				11802	.202	
	TUBULAR	CODE							
	BRAZED	CODE							
RF	TUBULAR	AIRCRAFT	11823 (SET)		11802	.254			
	TUBULAR	CODE							
	BRAZED	CODE							
RG	TUBULAR	AIRCRAFT	11824 (SET)			11802		.321	
		CODE							
RH	TUBULAR	AIRCRAFT	11825 (SET)	11802				.339	
		CODE							
RJ	TUBULAR	AIRCRAFT	11826 (SET)					11802	.370
		CODE							
RK	TUBULAR	AIRCRAFT	11827 (SET)				11802		.382
		CODE							
RL	TUBULAR	AIRCRAFT	11828 (SET)		11802				.456
		CODE							
RM	TUBULAR	AIRCRAFT	11829 (SET)						11802
		CODE							

FOR PARTS OR SERVICE,
CONTACT THOMAS & BETTS TOOL SERVICE CENTER AT 1-800-284-TOOL (8665)

Thomas & Betts Corporation
Memphis, Tennessee
www.tnb.com