



StrongArm®

120 Volt AC ELECTRIC WINCHES

OWNER'S MANUAL

**MODELS SA5000AC, SA5015AC, SA7000AC, SA7015AC,
SA9000AC, SA9010AC, SA9015AC, SA12000AC & SA12015AC**



⚠ WARNING: READ INSTRUCTIONS CAREFULLY BEFORE ATTEMPTING TO INSTALL, OPERATE OR SERVICE THE *STRONGARM* ELECTRIC WINCH. FAILURE TO COMPLY WITH INSTRUCTIONS COULD RESULT IN SERIOUS OR FATAL INJURY. RETAIN INSTRUCTIONS FOR FUTURE REFERENCE.

WINCH RATINGS

ELECTRIC WINCH RATING*

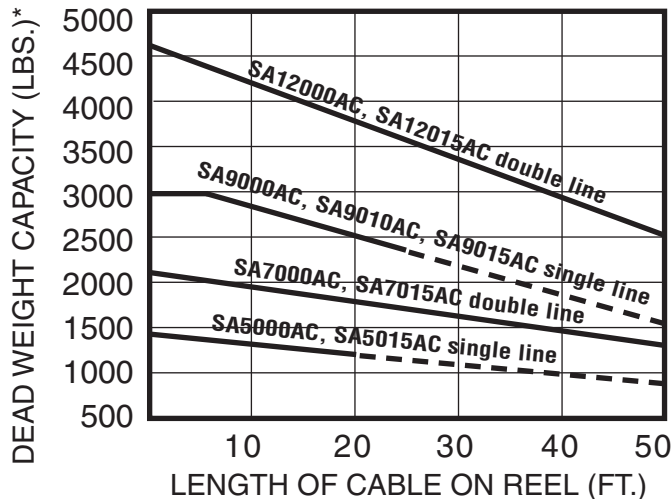

DOUBLE LINE OPERATION

Models SA7000AC, SA7015AC, SA12000AC and SA12015AC are factory equipped with a pulley block and hook and 50' of cable for double line operation. This increases the pulling capacity of the winch as shown, however, care must be taken to allow adequate motor cooling. Note that with double line, a pull of 25' requires reeling in 50' of cable.

For intermittent use only. Ratings at left are based on 10' pull. For longer pulls motor cooling periods must be allowed.

⚠ CAUTION: CONTINUOUS RUNNING IN EXCESS OF 3 MINUTES WILL DAMAGE WINCH MOTOR.

GUIDE TO ROLLING LOAD CAPACITY**

Maximum weight in pounds and kilograms rolling load.

MODEL	PERCENT INCLINE						LOAD CAPACITY*
	5% (3°)	10% (6°)	20% (11°)	30% (17°)	50% (26°)	70% (35°)	
SA5000AC, SA5015AC	8,000 lbs. 3,629 kg	6,000 lbs. 2,722 kg	4,000 lbs. 1,814 kg	3,100 lbs. 1,406 kg	2,200 lbs. 998 kg	1,800 lbs. 816 kg	1,200 lbs. 544 kg
SA7000AC, SA7015AC	12,000 lbs. 5,443 kg	9,000 lbs. 4,082 kg	6,100 lbs. 2,767 kg	4,600 lbs. 2,087 kg	3,300 lbs. 1,497 kg	2,700 lbs. 1,225 kg	1,800 lbs. 816 kg
SA9000AC, SA9010AC, SA9015AC	18,000 lbs. 8,165 kg	13,500 lbs. 6,124 kg	9,100 lbs. 4,128 kg	6,900 lbs. 3,130 kg	5,000 lbs. 2,268 kg	4,100 lbs. 1,860 kg	2,700 lbs. 1,225 kg
SA12000AC, SA12015AC	26,700 lbs. 12,111 kg	20,100 lbs. 9,117 kg	13,600 lbs. 6,169 kg	10,300 lbs. 4,672 kg	7,400 lbs. 3,357 kg	6,100 lbs. 2,767 kg	4,000 lbs. 1,814 kg

APPROXIMATE LOAD SPEED

(FT./MIN.)

	NO LOAD		FULL LOAD	
	Full Reel	Empty Reel	Full Reel	Empty Reel
SA5000AC, SA5015AC	35	16	16	9
SA7000AC, SA7015AC	17.5	8	9.5	6
SA9000AC, SA9010AC, SA9015AC	18	6	7	3.5
SA12000AC, SA12015AC	9	3	4	2

⚠ WARNING: NOT TO BE USED AS A HOIST FOR LIFTING, SUPPORTING OR TRANSPORTING PEOPLE OR LOADS OVER AREAS WHERE PEOPLE COULD BE PRESENT!

(*) Load capacity (dead weight) is a measure of actual maximum force to which the winch system may be subjected.

(**) All capacities shown are with 15' of cable on the reel and 10% rolling friction factor. For full reel of cable adjust capacities according to graph above. Note 5% incline is one-half foot rise in ten feet.

IMPORTANT SAFETY INFORMATION

⚠ WARNING: FAILURE TO READ AND FOLLOW INSTRUCTIONS BELOW COULD RESULT IN SERIOUS OR FATAL INJURY.

⚠ WARNING: NOT TO BE USED AS A HOIST FOR LIFTING, SUPPORTING, OR TRANSPORTING PEOPLE OR LOADS OVER AREAS WHERE PEOPLE COULD BE PRESENT.

⚠ This winch is not designed for movement of human beings. Do not use for scaffolding, elevators, or any other application in which persons could be positioned on or under the load at any time. Do not use as an overhead hoist.

⚠ This electric winch should be respected as power equipment. High forces are created when using a winch, creating potential safety hazards. Never allow children or anyone who is not familiar with the operation of the winch to use it.

⚠ Never exceed rated winch capacity. Dangerously high forces can be created if the load being moved is too large or is allowed to get in a bind, etc. Note that installing longer than normal cable results in increased load on winch. If overloaded, this winch has power enough to break the cable.

⚠ Inspect the winch cable often and replace at the first sign of damage. Never exceed the winch capacity. When cable breaks under tension, it tends to whip toward the winch area. It is recommended that a blanket or rug be placed over the cable during winching operations to minimize this whipping action in case of cable breakage.

⚠ Never apply load to winch with cable fully extended. Keep at least three turns of cable on the reel.

⚠ Keep the winching area free of all unnecessary personnel. Never stand between load and winch.

⚠ When winching operation has been completed, do not depend on the winch to support the load. Always secure the load properly. Use tie down straps or chains.

⚠ The auxiliary handle is provided for emergency use only. Never use the auxiliary handle as an assist to the motor when the motor is running. Always remove the auxiliary handle when it is not in use. Do not operate the winch motor with the handle installed.

⚠ Keep hands and fingers clear of the drum and cable area of the winch when operating. Do not attempt to guide the cable by hand as it rewinds on the drum.

⚠ Special care should be taken with 120-volt AC winch, as with any other 120-volt tools. Some winch models are equipped with a ground fault circuit interrupter in the power cord. Read and follow instructions on the back of the GFCI. The winch should be used only with a three pronged grounded outlet. Do not remove the grounding prong on the power cord for any reason. Do not operate the unit in the rain or when it is wet and never operate the winch while standing in water.

⚠ The winch must be securely attached to a structural member or frame that is capable of sustaining loads in excess of the winch capacity.

⚠ Periodically check the power cord for wear or frays which could cause electrical shorts or shocks.

MOUNTING INSTRUCTIONS

Be sure that the mounting surface is of sufficient strength to support a load well in excess of the rated winch capacity. Fasten the winch to the mounting surface with three 1/2" bolts, nuts, washers, and lockwashers. (See base hole pattern.) Be sure that the winch is positioned so that the cable does not rub the front opening of the winch. Your winch is equipped with key hole slots in the base for use with quick-mounting shoulder studs if desirable. If you wish to use quick-mount studs, they should be mounted securely into the mounting surface. After positioning the winch on the studs, a 3/8" bolt should be placed in one of the other holes available to keep the winch securely in position. For double line use, install an eye-hook on the mounting surface close to the base of the winch for fastening the stationary cable hook. Be sure the eye-hook is of sufficient strength to withstand loads in excess of the single line rating of the winch.

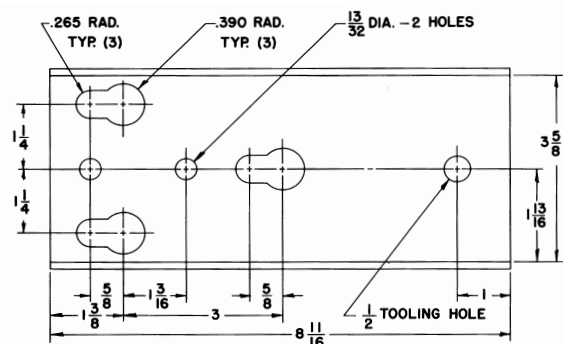

BASE HOLE PATTERN

SA5000AC, SA5015AC, SA7000AC and SA7015AC

Continued on next page

MOUNTING INSTRUCTIONS continued

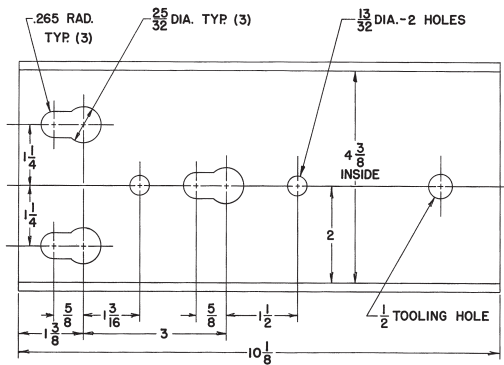

BASE HOLE PATTERN
SA9000AC, SA9010AC, SA9015AC,
SA12000AC and SA12015AC

OPERATING INSTRUCTIONS

All models can be powered in or out. Allowing the switch to return to the off position will automatically stop the winch and hold the load.

For units with the hand held Dynamic Brake Remote Control, press the "In/Out" switch to the desired direction and then push and hold the "Run" switch to power the winch.

⚠ CAUTION: Do not change cable direction while the motor is running. Changing directions prior to releasing the "Run" switch may result in winch or motor damage.

It is recommended that whenever the winch is not being used that it be unplugged from the power supply. The bridge is subject to damage caused by electrical storms or voltage surges if the winch is left plugged in when not in use.

NOTE: Some models are supplied with a GFCI cord set. To ensure protection against electrical shock, test the GFCI before each use. See back of GFCI for test procedure.

NOTE: It is normal for smoke to be produced during the initial power down use.

⚠ WARNING: BECAUSE THE WINCH IS NOT EQUIPPED WITH CIRCUIT BREAKER OVERLOAD PROTECTION, PARTICULAR CARE SHOULD BE TAKEN NOT TO CREATE AN OVERLOAD. PAY ATTENTION TO THE SOUND OF THE WINCH AND THE LOAD BEING PULLED. MAKE CERTAIN THAT THE CABLE TENSION DOES NOT RISE SUDDENLY BECAUSE OF A BIND IN THE LOAD.

⚠ CAUTION: The electric motor is designed for intermittent service only. Extended use without cooling off periods will cause overheating resulting in motor damage. Maximum continuous run time is three minutes.

⚠ WARNING: NEVER ALLOW CHILDREN, OR ANYONE WHO IS NOT FAMILIAR WITH THE OPERATION OF THE WINCH, TO USE IT.

AUXILIARY HANDLE

1. An emergency crank handle is provided for use in the event of a power failure. Remove the electrical power from the winch.
2. Remove the plastic plug from the side of the winch housing and insert the handle so that it completely engages with the drive shaft. The handle can be cranked in either direction.

⚠ WARNING: NEVER OPERATE THE WINCH ELECTRICALLY WITH THE EMERGENCY HANDLE IN POSITION.

3. Always remove the handle from the winch after use and replace the plastic plug.

WINCH MAINTENANCE

For long life and trouble-free operation your winch should periodically be inspected for any required maintenance. This should be done at least once annually and more frequently in adverse conditions such as salt water areas or areas of extreme dust and dirt.

1. Carefully inspect the winch cable for any kinks, frays or abnormal stiffness and replace at the first sign of this kind of damage. Periodic lubrication with a light oil will improve the life of the cable. In order to replace the winch cable, it is necessary to remove the four cover mounting bolts. Be sure that the power is disconnected from the housing and lift the housing off of the winch by gently stretching it open near the lower front corner. Rotate the winch reel so that you have access to the rope clamp. Remove the old cable and replace it with a new cable of the same size. Be sure that the cable passes under both sides of the rope clamp and that the clamp is tightened securely.

NOTE: CABLE IS WOUND OVER THE TOP OF THE DRUM ON MODELS SA5000AC, SA5015AC, SA7000AC, SA7015AC AND UNDER THE DRUM ON MODELS SA9000AC, SA9010AC, SA9015AC, SA12000AC AND SA12015AC. SEE ATTACHMENT METHOD BELOW.

CABLE ATTACHMENT METHODS

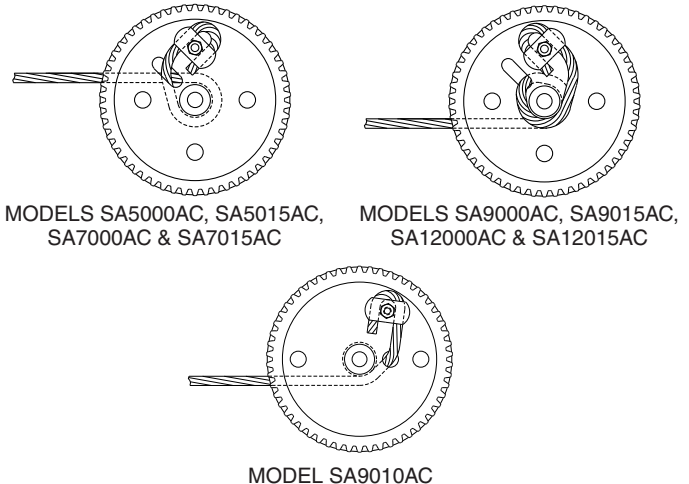

2. With the cover removed as described above, inspect the entire gear train and all drive shafts for any significant wear or loose bearing fits. Grease all of the gears on the inside of

the winch base and apply a drop of oil on all of the bearings in the base. Also, place a drop of oil on the roller clutch. Do not over lubricate these areas and do not use grease in the roller clutch. The brake pads and brake disc must be kept clean and oil free.

3. Check the operation of the roller clutch. Carefully rotate the brake disc and observe the motor shaft. When the disc is turned clockwise the motor shaft should turn with

it. When the disc is turned counterclockwise the motor shaft should not turn. Also, check all nuts, bolts, retaining rings, etc., to be sure that they are tight and secure.

4. If a pulley block and hook is used, check assembly to be sure that the pulley rotates freely on the bronze pulley spacer. Occasional greasing of these two items is recommended.

TROUBLESHOOTING CHART

SYMPTOM	POSSIBLE CAUSE(S)	CORRECTIVE ACTION
Safety hook spreads.	1. Point loading of hook. 2. Load exceeds rated capacity of unit.	1. Replace hook. 2. Lighten load, reduce % of incline or reduce load friction.
Cable snaps.	1. Improperly maintained cable. 2. Overloading.	1. See "Maintenance". 2. Reduce load.
Cable miswrap and/or crushing.	Loose cable being wound onto drum.	Keep tension on cable at all times.
Load creeps when power is OFF.	1. Roller clutch, not engaging. 2. Overloading.	1. Replace. 2. Reduce load.
Damaged level wind spring Models SA9000AC, SA9010AC, SA9015AC, SA12000AC & SA12015AC.	Loose cable.	Keep tension on cable at all times.
Winch motor runs hot.	In operation too long.	Let motor cool for at least 20 minutes. (See Winch Rating Section).
Winch motor fails to run.	Electrical.	Check the following: power supply, wiring, control switch, male/female connections and motor.
Winch pops circuit breaker immediately when plugged in.	Damaged bridge.	Replace bridge and keep winch unplugged when not in use.
GFCI interrupts circuit or will not reset.	Possible short or electrical leakage.	Correct electrical problem and reset GFCI.
GFCI does not test properly.	Faulty GFCI.	Replace GFCI.
Smokes.	Normal on initial power down use.	None.

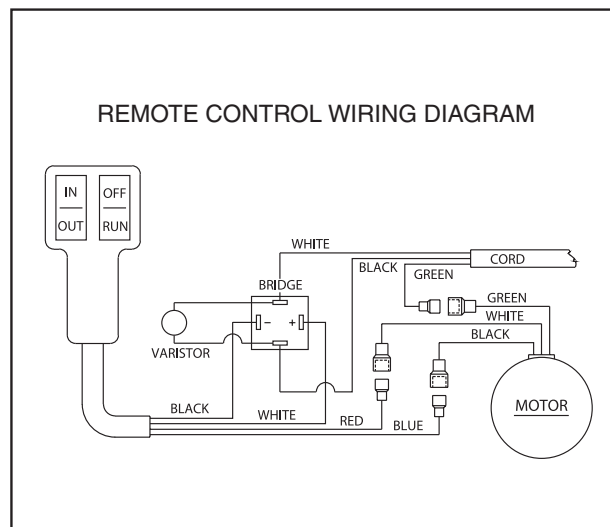
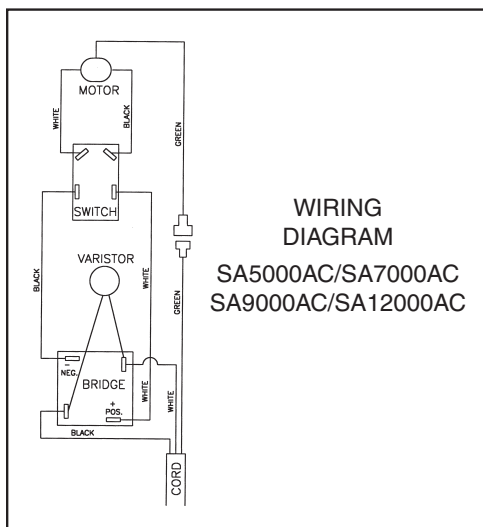

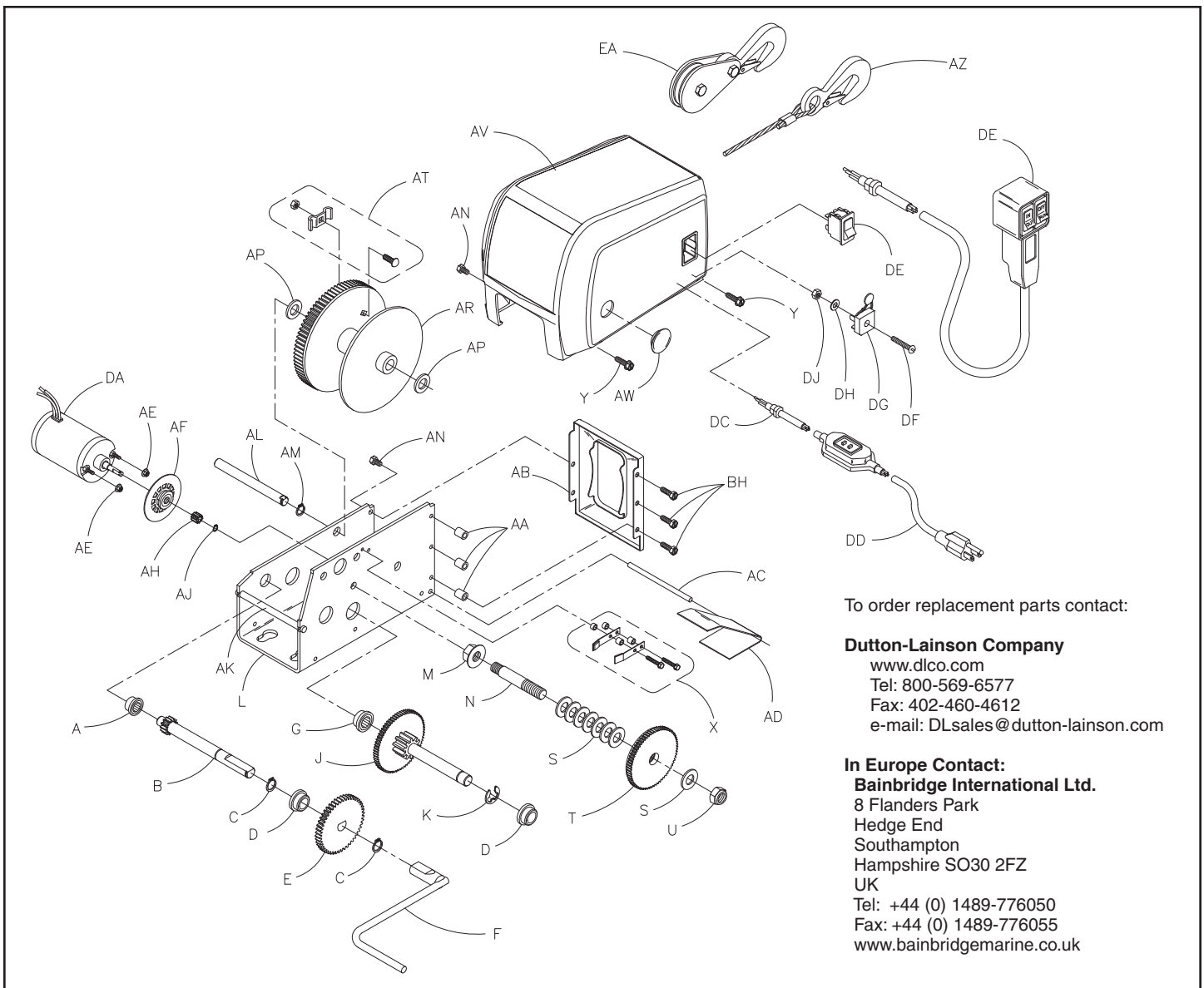

To order replacement parts contact:

Dutton-Lainson Company

www.dlco.com
 Tel: 800-569-6577
 Fax: 402-460-4612
 e-mail: DLsales@dutton-lainson.com

In Europe Contact:

Bainbridge International Ltd.

8 Flanders Park
 Hedge End
 Southampton
 Hampshire SO30 2FZ
 UK
 Tel: +44 (0) 1489-776050
 Fax: +44 (0) 1489-776055
 www.bainbridgemarine.co.uk

SA9000AC, SA9010AC, SA9015AC, SA12000AC, SA12015AC

Ref. Part	Number	Ref. Part	Number	Ref. Part	Number
A Bearing Housing Assy.	304314	AA Spacer (3)	404513	AW Cover Plug	204713
B Primary Drive Shaft Assy.	304304	AB Front Plate	404511	AZ Cable & Hook (Optional) Contact	
C Retaining Ring (2)	205191	AC Level Wind Pin (Optional)	404516	Manuf. for sizes available.	
D Bushing (2)	204012	AD Level Wind (Optional)	204709	BE Top Decal (AC) (Not Shown)	206041
E 56T Gear	204703	AE Nut, 10-32 Locknut (2)	205193	BH Screw 1/4-20x7/8 (3)	205242
F Aux. Handle Assy.	304412	AF Brake Disc Assy. (Roller Clutch)	304422	DA Motor Assy	304921
G Drive Shaft Bearing Housing Assy.	304313	AH 12T Pinion Gear	404522	DC Strain Relief Bushing	205037
J Interm. Drive Shaft Assy.	304814	AJ "E" Ring	205135	DD Electrical Cord, GFCI	5240189
K "E" Ring	205116	AK Base Spacer	404510	DD Cord	205038
L Base	404921	AL Reel Shaft	404514	DE Dual Switch Remote Ass'y	5240890
M Nut, 7/16-20 Locknut	205192	AM Retaining Ring	204468	DE Single Switch Remote Ass'y	5240528
N Clutch Stud	404535	AN Screw, 1/4x20x1/2" (4)	205189	DE Switch	204419
S Washer (8)	204360	AP Washer (2)	205109	DF Screw 8-32x1" Lg.	205180
T Gear Assy.	304319	AR Reel Assy. (SA9010AC)	304823	DG Bridge Assy.	304426
U Nut	205015	AR Reel Assy.	304815	DH Lockwasher - #8 Inter.	205194
X Brake Spring Replacement Kit	5703160	AT Rope Clamp Kit	5243506	DJ Nut, 8-32	205195
Y Screw, 1/4-20x1" (2)	205190	AV Cover (For Remote Switch)	404915	EA Pulley Block & Hook (Complete)	5240270
		AV Cover (CSA)	404594	(Optional)	
		AV Cover (AC)	404631		
		AV Cover (CSA - For Remote Switch)	406050		



A Dependable Company Since 1886
DUTTON-LAINSON COMPANY
 Hastings, NE 68902 U.S.A • Tel 402-462-4141 • Fax 402-460-4612
 E-mail dlsales@dutton-lainson.com • Web Site www.dutton-lainson.com

**MADE IN
 USA**