



# StrongArm®

## 120 Volt AC ELECTRIC WINCHES

# OWNER'S MANUAL

## MODELS SA5000AC, SA7000AC, SA9000AC, SA12000AC



**⚠ WARNING:** READ INSTRUCTIONS CAREFULLY BEFORE ATTEMPTING TO INSTALL, OPERATE OR SERVICE THE **STRONGARM** ELECTRIC WINCH. FAILURE TO COMPLY WITH INSTRUCTIONS COULD RESULT IN SERIOUS OR FATAL INJURY. RETAIN INSTRUCTIONS FOR FUTURE REFERENCE.

## WINCH RATINGS

### ELECTRIC WINCH RATING\*

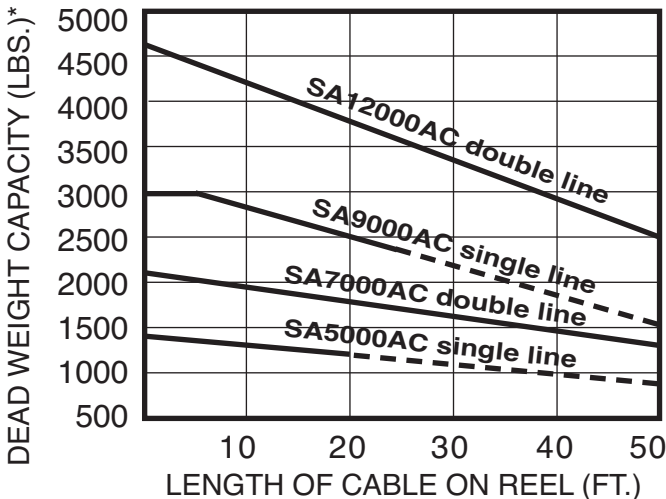

### DOUBLE LINE OPERATION

Models SA7000AC and SA12000AC are factory equipped with a pulley block and hook and 50' of cable for double line operation. This increases the pulling capacity of the winch as shown, however, care must be taken to allow adequate motor cooling. Note that with double line, a pull of 25' requires reeling in 50' of cable.

For intermittent use only. Ratings at left are based on 10' pull. For longer pulls motor cooling periods must be allowed.

MAXIMUM CONTINUOUS RUN TIME 3 MINUTES

**⚠ CAUTION:** CONTINUOUS RUNNING IN EXCESS OF 3 MINUTES WILL DAMAGE WINCH MOTOR.

### GUIDE TO ROLLING LOAD CAPACITY\*\*

Maximum weight in pounds and kilograms rolling load.

MODEL	PERCENT INCLINE						LOAD CAPACITY*
	5% (3°)	10% (6°)	20% (11°)	30% (17°)	50% (26°)	70% (35°)	
SA5000AC	8,000 lbs. 3,629 kg	6,000 lbs. 2,722 kg	4,000 lbs. 1,814 kg	3,100 lbs. 1,406 kg	2,200 lbs. 998 kg	1,800 lbs. 816 kg	1,200 lbs. 544 kg
SA7000AC	12,000 lbs. 5,443 kg	9,000 lbs. 4,082 kg	6,100 lbs. 2,767 kg	4,600 lbs. 2,087 kg	3,300 lbs. 1,497 kg	2,700 lbs. 1,225 kg	1,800 lbs. 816 kg
SA9000AC	18,000 lbs. 8,165 kg	13,500 lbs. 6,124 kg	9,100 lbs. 4,128 kg	6,900 lbs. 3,130 kg	5,000 lbs. 2,268 kg	4,100 lbs. 1,860 kg	2,700 lbs. 1,225 kg
SA12000AC	26,700 lbs. 12,111 kg	20,100 lbs. 9,117 kg	13,600 lbs. 6,169 kg	10,300 lbs. 4,672 kg	7,400 lbs. 3,357 kg	6,100 lbs. 2,767 kg	4,000 lbs. 1,814 kg

### APPROXIMATE LOAD SPEED (FT./MIN.)

	NO LOAD		FULL LOAD	
	Full Reel	Empty Reel	Full Reel	Empty Reel
SA5000AC	35	16	16	9
SA7000AC	17.5	8	9.5	6
SA9000AC	18	6	7	3.5
SA12000AC	9	3	4	2

(\*) Load capacity (dead weight) is a measure of actual maximum force to which the winch system may be subjected.

(\*\*) All capacities shown are with 15' of cable on the reel and 10% rolling friction factor. For full reel of cable adjust capacities according to graph above. Note 5% incline is one-half foot rise in ten feet.

**⚠ WARNING:** NOT TO BE USED AS A HOIST FOR LIFTING, SUPPORTING OR TRANSPORTING PEOPLE OR LOADS OVER AREAS WHERE PEOPLE COULD BE PRESENT!

E  
N  
G  
L  
I  
S  
H

E  
S  
P  
A  
Ñ  
O  
L

F  
R  
A  
N  
Ç  
A  
I  
S

# IMPORTANT SAFETY INFORMATION

**⚠ WARNING: FAILURE TO READ AND FOLLOW INSTRUCTIONS BELOW COULD RESULT IN SERIOUS OR FATAL INJURY.**

**⚠ WARNING: NOT TO BE USED AS A HOIST FOR LIFTING, SUPPORTING, OR TRANSPORTING PEOPLE OR LOADS OVER AREAS WHERE PEOPLE COULD BE PRESENT.**

⚠ This winch is not designed for movement of human beings. Do not use for scaffolding, elevators, or any other application in which persons could be positioned on or under the load at any time. Do not use as an overhead hoist.

⚠ Consult the manufacturer before using this winch in any vertical lifting/lowering applications. Tel. 402-462-4141, Fax 402-460-4613  
E-Mail [dlsales@dutton-lainson.com](mailto:dlsales@dutton-lainson.com)

⚠ This electric winch should be respected as power equipment. High forces are created when using a winch, creating potential safety hazards. Never allow children or anyone who is not familiar with the operation of the winch to use it.

⚠ Never exceed rated winch load. Dangerously high forces can be created if the load being moved is too large or is allowed to get in a bind, etc. Note that installing longer than normal cable results in increased load on winch. If overloaded, this winch has power enough to break the cable.

⚠ Winch is equipped with a high-quality aircraft cable capable of handling the rated winch load. Never exceed the rated capacity. Do not use vehicle pulling power to increase the pulling capacity of your winch. When cable breakage occurs under tension, the cable tends to whip toward the winch area. It is recommended that a blanket or rug be placed over the cable during winching operations to minimize this whipping action in case of cable breakage.

⚠ Never apply load to winch with cable fully extended. Keep at least three turns of cable on the reel.

⚠ Keep the winching area free of all unnecessary personnel. Never stand between load and winch.

⚠ When winching operation has been completed, do not depend on the winch to support the load. Always secure the load properly. Use tie down straps or chains.

⚠ The auxiliary handle is provided for emergency use only. Never use the auxiliary handle as an assist to the motor when the motor is running. Always remove the auxiliary handle when it is not in use. Do not operate the winch motor or allow the winch to free wheel with the handle installed.

⚠ Special care should be taken with 120-volt AC winches, as with any other 120-volt tools. It is recommended that whenever a 120-volt AC winch is out-of-doors that it be used with a ground fault circuit interrupter. The winch should be used only with a three pronged grounded outlet. Do not remove the grounding prong on the power cord for any reason. Do not operate the unit in the rain or when it is wet. Avoid using the winch around water or water pipes and never operate the winch while standing in water.

⚠ Periodically check the power cord for wear or frays which could cause electrical shorts or shocks.

⚠ Keep hands and fingers clear of the drum and cable area of the winch when operating. Do not attempt to guide the cable by hand as it rewinds on the drum.

⚠ The winch must be securely attached to a structural member or frame that is capable of sustaining loads in excess of the winch capacity. When attaching the winch to a vehicle, make sure the mounting pad area is rigidly supported by the vehicle frame. Always block the wheels to prevent vehicle from rolling when pulling a load with the winch.

⚠ When releasing a load with the clutch, maintain control of the speed. Excess speed could result in winch damage and serious personal injury.

## MOUNTING INSTRUCTIONS

1. Be sure that the mounting surface is of sufficient strength to support a load well in excess of the rated winch capacity.
2. Fasten the winch to the trailer winch stand (or other mounting surface) with three 1/2" bolts, nuts, washers and lock washers. Be sure that the winch is positioned so that the cable does not rub the front opening of the winch.
3. For double line use, install an eyehook on the winch stand close to the base of the winch for fastening the stationary cable hook. (see Fig. 1) Be sure the eyehook is of sufficient strength to withstand loads in excess of the single line rating of the winch.

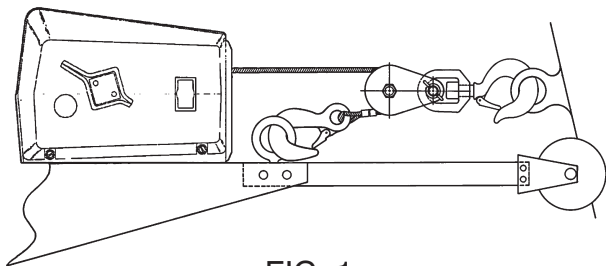
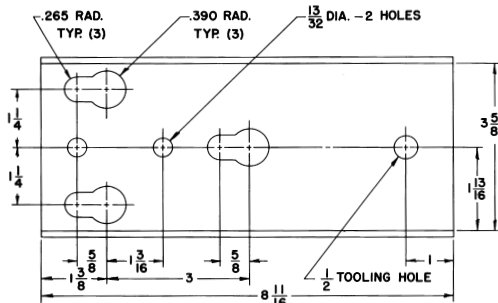
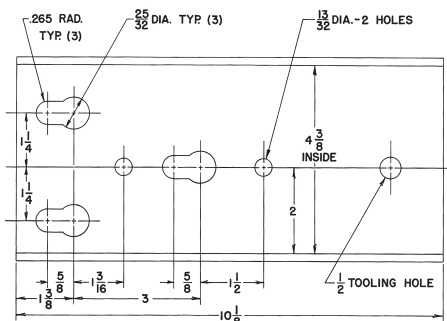

FIG. 1

4. Your winch is equipped with keyhole slots in the base for use with quick mounting shoulder studs, if desirable. (See FIG. 2&3) If you wish to use quick mount studs, they should be mounted securely into the winch stand. After positioning the winch on the studs, a 3/8" bolt should be placed in one of the other holes available to keep the winch securely in position.

FIG. 2  
BASE HOLE PATTERN  
(SA5000AC & SA7000AC)FIG. 3  
BASE HOLE PATTERN  
(SA9000AC & SA12000AC)

## LOADING AND UNLOADING UNDER POWER

With the clutch in the engaged gears position, you may power the winch in either the "in" or "out" direction.

1. To operate the unit, simply press the switch "in" for loading and "out" for unloading.
2. Allowing the switch to return to the OFF position will automatically stop the winch and lock the load in position.

NOTE: It is normal for smoke to be produced during the initial power down use.

**⚠ WARNING: BECAUSE THE WINCH IS NOT EQUIPPED WITH CIRCUIT BREAKER OVERLOAD PROTECTION, PARTICULAR CARE SHOULD BE TAKEN NOT TO CREATE AN OVERLOAD. PAY ATTENTION TO THE SOUND OF THE WINCH AND THE LOAD BEING PULLED. MAKE CERTAIN THAT THE CABLE TENSION DOES NOT RISE SUDDENLY BECAUSE OF A BIND IN THE LOAD.**

**⚠ CAUTION: The electric motor is designed for intermittent service only. Extended use without cooling off periods will cause overheating resulting in motor damage. Maximum recommended continuous run time is three minutes.**

3. It is recommended that whenever the winch is not being used that it be unplugged from the power supply. The bridge is subject to damage caused by electrical storms or voltage surges if the winch is left plugged in when not in use.

## CLUTCH OPERATION

1. The clutch lever provides a means for releasing a load without power while maintaining control of the speed and provides for free wheeling so that cable can be removed from the winch by hand. The clutch lever is spring loaded so that it returns to the engaged position when released. The lever will, however, remain in the free wheeling position if rotated completely forward to free wheel.
2. In order to release a load without power, rotate the clutch lever slowly and carefully forward toward "Free Wheel." When the load begins to move, it can be controlled by the clutch lever. Careful, slow movement of the lever will provide smooth control of the load.

**⚠ WARNING: ALWAYS MAINTAIN CONTROL OF THE LOAD. ALLOWING EXCESS SPEED COULD RESULT IN WINCH DAMAGE AND SEVERE PERSONAL INJURY.**

3. Remember that the gear train and brake mechanism are completely disengaged in the "Free Wheel" position and in order to power the winch or hold a load in position, the lever must be allowed to return to the "Engaged Gears" position.

NOTE: It is not necessary to turn the clutch lever completely to the "Engaged Gears" position manually. The spring tension built into the winch provides adequate force on the clutch lever.

**⚠ CAUTION: Never force clutch lever in either direction.**

## AUXILIARY HANDLE

1. An emergency crank handle is provided for use in the event of a power failure. Remove the electrical power from the winch.

**⚠ WARNING: NEVER OPERATE THE WINCH ELECTRICALLY WITH THE EMERGENCY HANDLE IN POSITION.**

2. Remove the plastic plug from the side of the winch housing and insert the handle so that it completely engages with the drive shaft. The handle can be cranked in either direction with the clutch in the engaged position. To make cranking easier, the clutch can be placed in the free wheel position while holding onto the emergency handle.

**⚠ WARNING: IF THE CLUTCH IS PLACED IN FREE WHEEL FOR HAND CRANKING, BE SURE TO MAINTAIN A FIRM GRIP ON THE HANDLE AT ALL TIMES.**

Because the emergency crank handle for models SA9000AC and SA12000AC attaches to the clutch side of the winch, it is equipped with a spring operated clip which will be depressed by the clutch handle in the free wheel position when cranking in a clockwise direction to retrieve the cable. This clip is a safety feature and will re-engage the clutch mechanism in the event that the operator loses control of the handle with a load on the winch. (See FIG. 4)

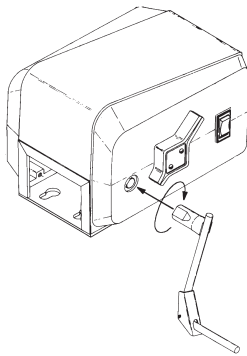

Emergency Handle  
Illustration

FIG. 4

**⚠ WARNING: EVEN WITH THIS SAFETY FEATURE THE HANDLE WILL STILL SPIN VIOLENTLY ONE OR TWO TURNS BEFORE RE-ENGAGING THE CLUTCH TO STOP THE WINCH. DO NOT LOSE CONTROL.**

3. Always remove the handle from the winch after use and replace the plastic plug.

## WINCH MAINTENANCE

For long life and trouble-free operation your winch should periodically be inspected for any required maintenance. This should be done at least once annually and more frequently in adverse conditions such as salt water areas or areas of extreme dust and dirt.

1. Carefully inspect the winch cable for any kinks, frays or abnormal stiffness and replace at the first sign of this kind of damage. Periodic lubrication with a light oil will improve the life of the cable. In order to replace the winch cable, it is necessary to remove the clutch handle, by removing the two clutch

handle screws, and the four cover mounting bolts. Be sure that the power is disconnected from the housing and lift the housing off of the winch by gently stretching it open near the lower front corner. Rotate the winch reel so that you have access to the rope clamp. Remove the old cable and replace it with a new cable of the same size. Be sure that the cable passes under both sides of the rope clamp and that the clamp is tightened securely. NOTE: CABLE IS WOUND OVER THE TOP OF THE DRUM ON MODELS SA5000AC AND SA7000AC AND UNDER THE DRUM ON MODELS SA9000AC AND SA12000AC. SEE ATTACHMENT METHOD BELOW (FIG. 5).

## CABLE ATTACHMENT METHODS

FIG. 5

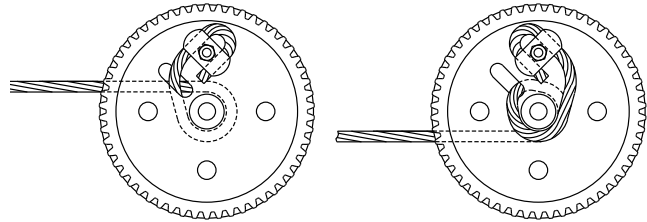

Model SA5000/7000AC

Model SA9000/12000AC

2. With the cover removed as described above, inspect the entire gear train and all drive shafts for any significant wear or loose bearing fits. Grease all of the gears on the inside of the winch base and apply a drop of oil on all of the bearings in the base. Also, very sparingly oil all of the bearings in the clutch mechanism and place a drop of oil on the roller clutch. Do not over lubricate these areas and do not use grease in the roller clutch. The clutch mechanism and the brake pads and brake disc must be kept clean and oil free.
3. Check the operation of the roller clutch. Carefully rotate the brake disc and observe the motor shaft. When the disc is turned clockwise the motor shaft should turn with it. When the disc is turned counter-clockwise the motor shaft should not turn. Also, check all nuts, bolts, retaining rings, etc., to be sure that they are tight and secure.
4. If the clutch has been slipping and requires adjustment the following procedures should be used. The clutch is adjustable in ten degree increments. With a screwdriver and pliers, remove the end of the clutch spring from the hole in the winch base. The spring tension is quite high so be careful to maintain a firm grip on the spring. The O-ring should be rotated so that the cut out portions align with the lugs on the spring keeper. (See FIG. 6)  
The ring can then be expanded with a pencil or similar object and the spring keeper can be lifted free from the clutch nut. Rotate the keeper clockwise 10 degrees and install on the next serration in the clutch nut. Reinstall O-ring and rotate slightly so that the cut outs are not in line with the lugs on the spring keeper and reinstall the clutch spring into the hole in the base. Adjustment of the clutch more than 10 degrees to 20 degrees should normally not be necessary. With only spring pressure (do not forcibly

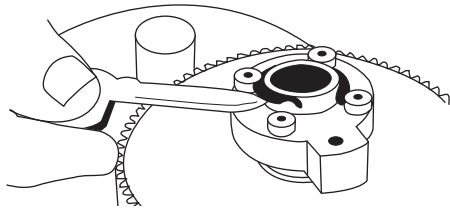

**O-Ring Illustration**

**FIG. 6**

tighten the clutch mechanism) the spring lug on the spring keeper should come to rest at approximately the 2:30 o'clock position. (See FIG. 7)

5. Check the pulley block and hook assembly (MODELS SA7000AC AND SA12000AC) to be sure that the pulley rotates freely on the bronze pulley spacer. Occasional greasing of these two items is recommended.

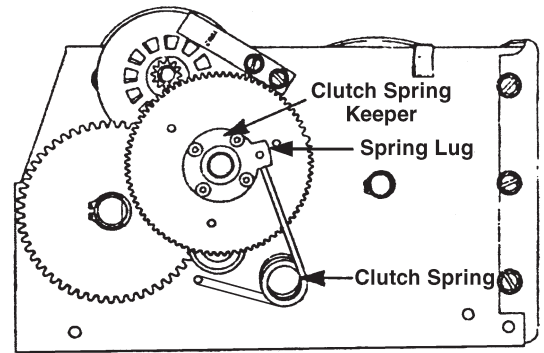

**FIG. 7**

**Clutch Spring Illustration**

E  
N  
G  
L  
I  
S  
H

## TROUBLESHOOTING CHART

SYMPTOM	POSSIBLE CAUSE(S)	CORRECTIVE ACTION
Safety hook spreads	<ol style="list-style-type: none"> <li>1. Point loading of hook</li> <li>2. Load exceeds rated capacity of unit</li> </ol>	<ol style="list-style-type: none"> <li>1. Replace hook</li> <li>2. Lighten load, reduce % of incline or reduce load friction</li> </ol>
Cable snaps	<ol style="list-style-type: none"> <li>1. Improperly maintained cable.</li> <li>2. Overloading</li> </ol>	<ol style="list-style-type: none"> <li>1. See "Maintenance"</li> <li>2. Reduce load</li> </ol>
Cable miswrap and/or crushing	Loose cable being wound onto drum	Keep tension on cable at all times
Load creeps when power is OFF	<ol style="list-style-type: none"> <li>1. Brake/clutch out of adjustment</li> <li>2. Roller clutch, not engaging</li> <li>3. Overloading</li> </ol>	<ol style="list-style-type: none"> <li>1. Adjust (see Maintenance).</li> <li>2. Replace.</li> <li>3. Reduce load.</li> </ol>
Winch motor runs but fails to wind cable	<ol style="list-style-type: none"> <li>1. Clutch is slipping.</li> <li>2. Gear train is damaged.</li> </ol>	<ol style="list-style-type: none"> <li>1. Check clutch lining for grease or oil. See "Maintenance" for clutch adjustment procedure.</li> <li>2. Check and Repair</li> </ol>
Winch motor runs hot	In operation too long	Let motor cool for at least 20 minutes. (See Winch Rating Section.)
Winch motor fails to run	Electrical	Check the following: power supply, wiring, control switch, male/female connections and motor.
Cable will not pull out (free wheel)	<ol style="list-style-type: none"> <li>1. Sticking cable</li> <li>2. Sticking clutch</li> </ol>	<ol style="list-style-type: none"> <li>1. Avoid cable miswrap.</li> <li>2.a. "Jog" power switch with clutch in free wheel (No load only).</li> <li>b. Disassemble, clean &amp; readjust clutch, see "Maintenance".</li> </ol>
Smokes	Normal on initial power down use	None

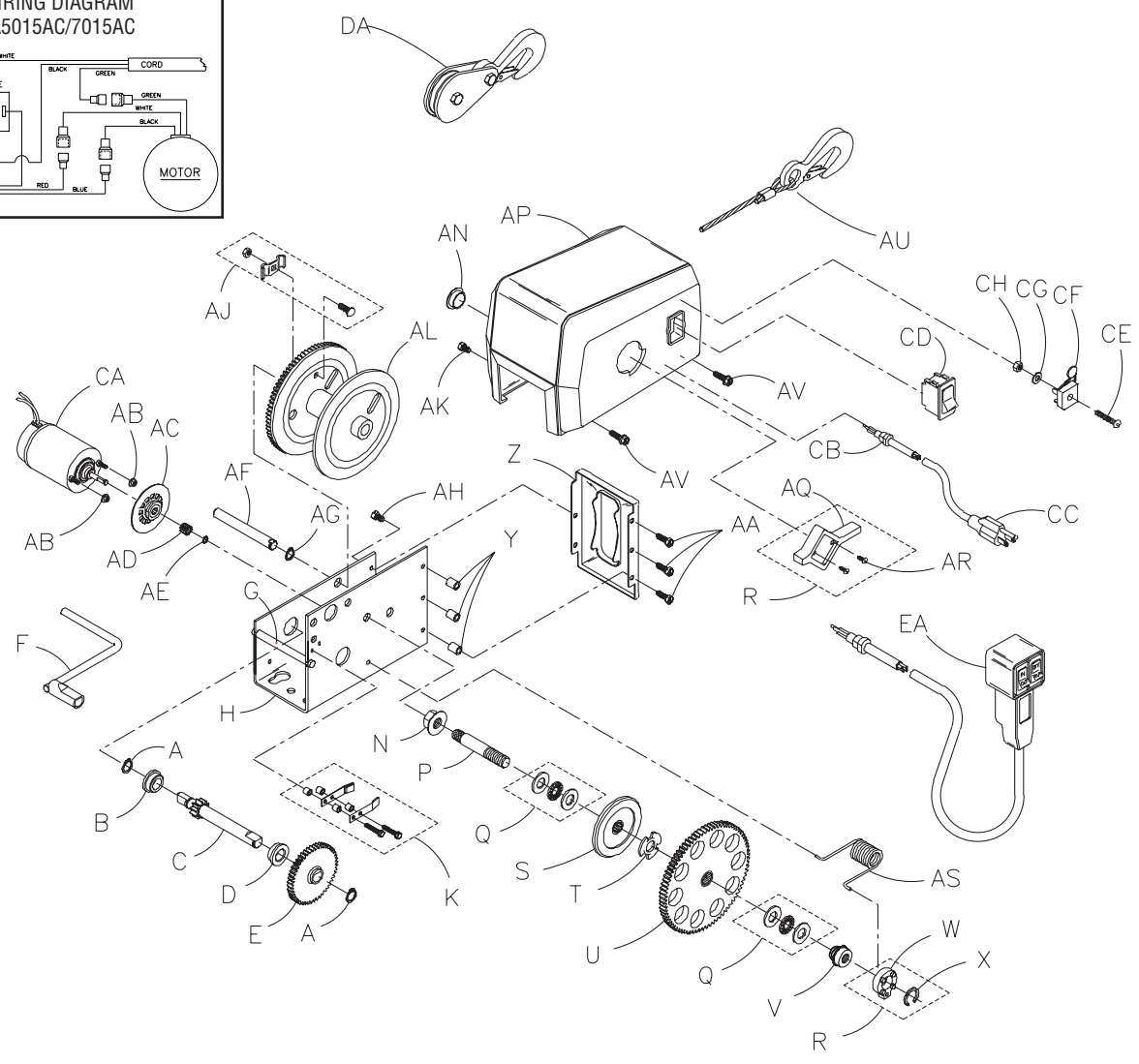
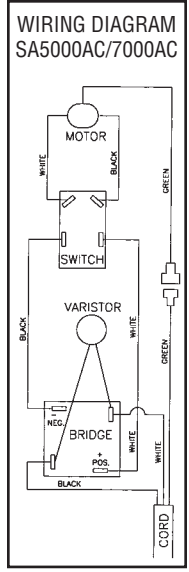
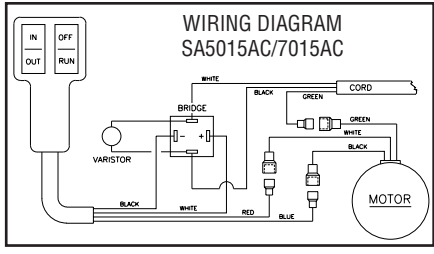

# SA5000AC and SA7000AC PARTS LIST

Ref. Part	Number	Ref. Part	Number	Ref. Part	Number
A Retaining Ring (2)	205191	AA Screw, 1/4-20x5/8 (3)	205238	<b>MOTOR PARTS</b>	
B Bushing	204012	AB Locknut, 10-32 (2)	205193	CA Motor Ass'y.	304921
C Drive Shaft Ass'y.	304813	AC Brake Disc Ass'y.	304407	CB Strain Relief Bushing	204912
D Bushing	204009	AD Motor Pinion	404522	CC Cord	205038
E 56T Gear	204703	AE 'E' Ring	205135	CD Switch	204419
F Handle Ass'y.	304412	AF Reel Shaft	404559	CE Cap Screw	205180
G Base Spacer	404557	AG Retaining Ring	204468	CF Bridge Ass'y.	304426
H Base	404922	AH Screw, 1/4-20x3/8 (2)	205337	CG Washer	205194
K Brake Spring Replacement Kit	5703186	AJ Cable Clamp Kit	304617	CH Hex Nut, 8-32	205195
N Locknut, 7/16-20	205192	AK Screw, 1/4-20x3/4 (2)	205338		
P Clutch Stud	404517	AL Reel Ass'y.	304812	<b>PULLEY BLOCK</b>	
Q Thrust Bearing Replacement Kit (Includes Item X)	5703194	AN Cover Plug	204713	DA Pulley Block & Hook (Complete)	5240270
R Clutch Handle Replacement Kit (Inc. Items W, X, AQ & AR)	5703178	AP Cover-SA5000AC/7000AC	404564		
S Clutch Gear Ass'y.	306100	AP Cover-SA5015AC/7015AC	404582	<b>REMOTE SWITCH</b>	
T Finger Spring Washer	205200	AQ Clutch Handle	204712	EA Switch Ass'y.	5240890
U 120T Gear Ass'y.	306102	AR Screw, #4 (2)	205196		
V Clutch Handle Nut	404518	AS Clutch Spring	204661		
W Clutch Spring Keeper	204721	AU Cable & Hook-3/16x20' (SA5000AC)	5240692		
X 'O' Ring	204770	AU Cable & Hook-3/16x50' (SA7000AC)	5240445		
Y Front Plate Spacer (3)	404562	AV Screw, 1/4-20x7/8 (2)	205242		
Z Front Plate	404553	AW Top Decal (Not Shown)	204895		
		AY D-L Decal (Not Shown)	204729		
		AZ Clutch Decal (Not Shown)	204731		

To order replacement parts contact:  
**Dutton-Lainson Company**  
 www.dlco.com  
 Tel: 800-569-6577 • Fax: 402-460-4612  
 e-mail: DLsales@dutton-lainson.com

**In Europe Contact:**  
**Aqua-Marine International Ltd.**  
 8 Flanders Park • Hedge End, Southampton  
 Hants, England SO30 2FZ  
 Tel: +44 (0) 1489-776050  
 Fax: +44 (0) 1489-776055  
 e-mail: sales@aqua-marineint.co.uk

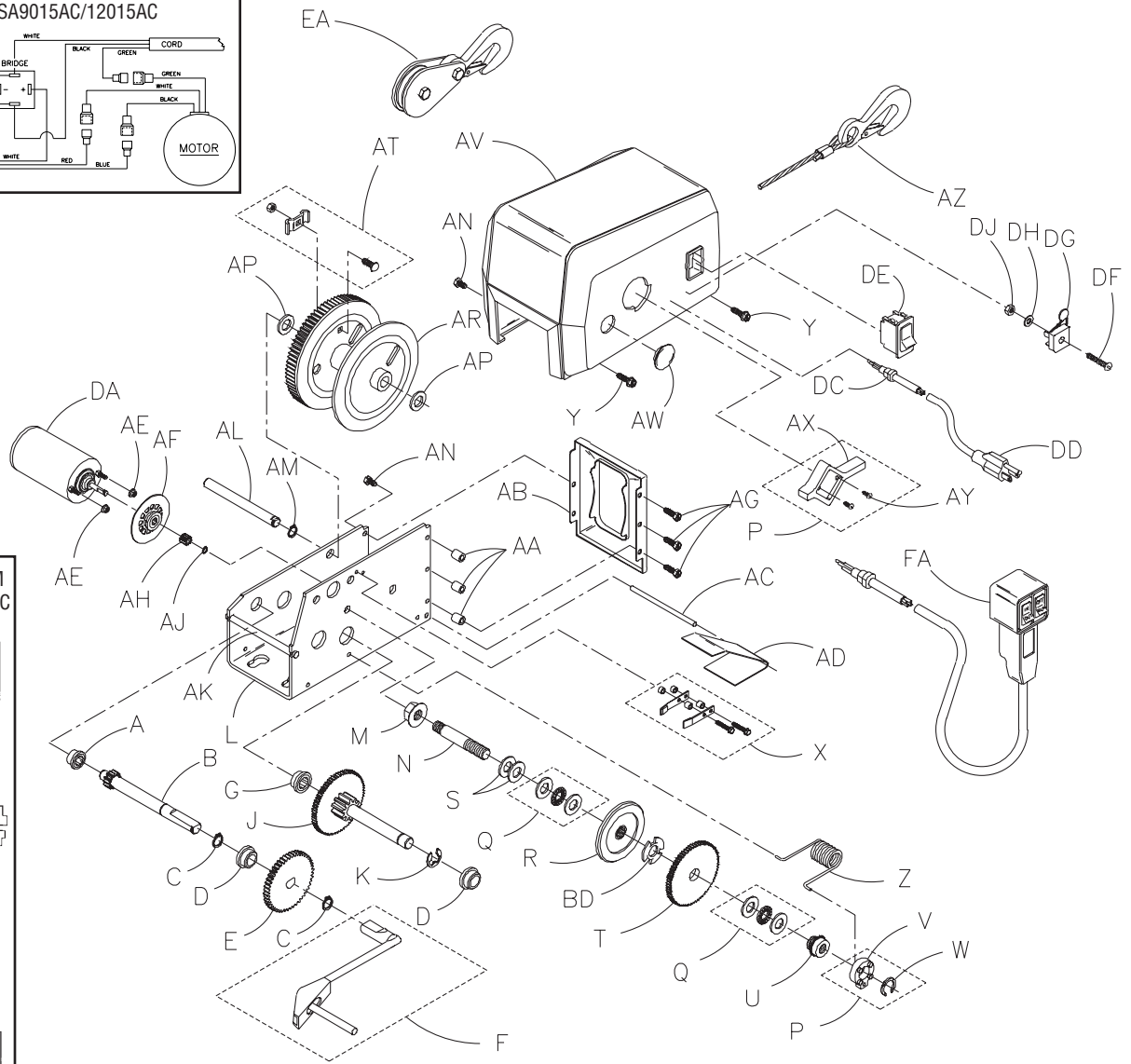
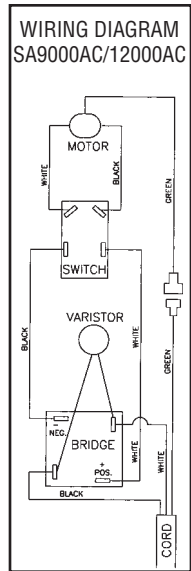
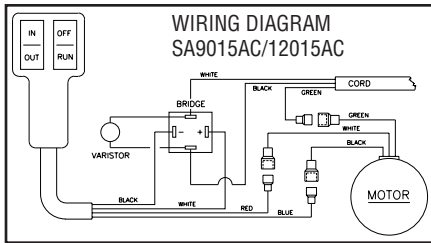

## SA9000AC and SA12000AC PARTS LIST

Ref. Part	Number	Ref. Part	Number	MOTOR PARTS	Number
A Bearing Housing Assy.	304314	AC Level Wind Pin	404516	DA Motor Assy	304921
B Primary Drive Shaft Assy.	304304	AD Level Wind	204709	DC Strain Relief Bushing	205037
C Retaining Ring (2)	205191	AE Nut, 10-32 Locknut (2)	205193	DD Electrical Cord	205038
D Bushing (2)	204012	AF Brake Disc Assy.	304422	DE Switch	204419
E 56T Gear	204703	AG Screw, 1/4-20x7/8 (3)	205242	DF Screw - 8-32x1"	205180
F Aux. Handle Assy.	5703079	AH 12T Pinion Gear	404522	DG Bridge Assy	304426
G Drive Shaft Bushing	304313	AJ "E" Ring	205135	DH Washer	205194
Housing Assy.		AK Base Spacer	404510	DJ Nut - 8-32	205195
J Interm. Drive Shaft Assy.	304814	AL Reel Shaft	404514	<b>PULLEY BLOCK</b>	
K "E" Ring	205116	AM Retaining Ring	204468	EA Pulley Block & Hook (Complete)	5240270
L Base	404921	AN Screw, 1/4x20x1/2" (4)	205189	<b>REMOTE SWITCH</b>	
M Nut, 7/16-20 Locknut	205192	AP Washer (2)	205109	FA Switch Assy	5240890
N Clutch Stud	404517	AR Reel Assy.	304815		
P Clutch Handle Replacement Kit	5703178	AT Rope Clamp Kit	5243506		
(Includes Items V, W, AX & AY)		AV Cover-SA9000/12000AC	204747		
Q Thrust Bearing Replacement Kit	5703194	AV Cover-SA9015AC/12015AC	204630		
(Includes Item W, O-Ring)		AW Cover Plug	204713		
R Clutch Gear Assy	306100	AX Clutch Handle	204712		
S Washer (2)	204360	AY Screw - #4x1/2	205196		
T 84T Gear Assy	306101	AZ Cable & Hook	5240478		
U Clutch Handle Nut	404518	(7/32x25") (SA9000AC)			
V Clutch Spring Keeper	204721	AZ Cable & Hook	5240452		
W "O"-Ring	204770	(7/32x50") (SA12000AC)			
X Brake Spring Replacement Kit	5703160	BD Finger Spring Washer	205200		
Y Screw, 1/4-20x1" (2)	205190	BE Top Decal (Not Shown)	204737		
Z Clutch Spring	204711	BG DL Decal (Not Shown)	204729		
AA Spacer (3)	404513	BH Clutch Decal (Not Shown)	204731		
AB Front Plate	404511				

To order replacement parts contact:  
**Dutton-Lainson Company**  
 www.dlco.com  
 Tel: 800-569-6577 • Fax: 402-460-4612  
 e-mail: DLsales@dutton-lainson.com

**In Europe Contact:**  
**Aqua-Marine International Ltd.**  
 8 Flanders Park • Hedge End, Southampton  
 Hants, England SO30 2FZ  
 Tel: +44 (0) 1489-776050  
 Fax: +44 (0) 1489-776055  
 e-mail: sales@aqua-marineint.co.uk



**ELECTRIC WINCH  
SERVICE CENTERS**

**FLORIDA**

Hagood Brothers Marine  
1121 West Church St.  
Orlando, FL 32805  
Tel: 407-843-4220

**MISSOURI**

Stewart Enterprises  
Route 2, Box 33C  
Cameron, MO 64429  
Tel: 816-632-6578

**NEBRASKA**

Dutton-Lainson Company  
1601 West 2nd  
Hastings, NE 68902  
Tel: 402-462-4141

**NEW YORK**

American Marine  
2161 Jericho Turnpike  
Commack, NY 11724  
Tel: 631-543-6433

E  
N  
G  
L  
I  
S  
H

These authorized centers will be able to supply parts and technical service on all StrongArm® Electric Winches  
For warranty claims follow instruction given in "Limited One Year Warranty."

**DECLARATION OF CONFORMITY** - Dutton-Lainson Company, Hastings, NE 68902-0729 U.S.A. manufactures and declares that the winch identified above fulfills all relevant provisions of the Directive 2006/42/EC. The technical file may be obtained from the persons listed below.

Hastings, NE USA  
January 4, 2010

*Ron Hease*  
Senior Vice President  
Dutton-Lainson Company

Peter Munday  
Bainbridge International Limited  
Unit 8, Flanders Park, Flanders Road, Hedge End  
Southampton, Hampshire, SO30 2FZ

**NOTES**

**WINCH MODEL NUMBER:** \_\_\_\_\_ **WINCH DATE CODE:** \_\_\_\_\_  
**DATE PURCHASED:** \_\_\_\_\_ **(LOCATED INSIDE FRAME AT REAR)**

\_\_\_\_\_  
\_\_\_\_\_  
\_\_\_\_\_  
\_\_\_\_\_  
\_\_\_\_\_  
\_\_\_\_\_  
\_\_\_\_\_