

# SPEAKMAN NEO™

## Showerhead S-3010

SPECIFICATION

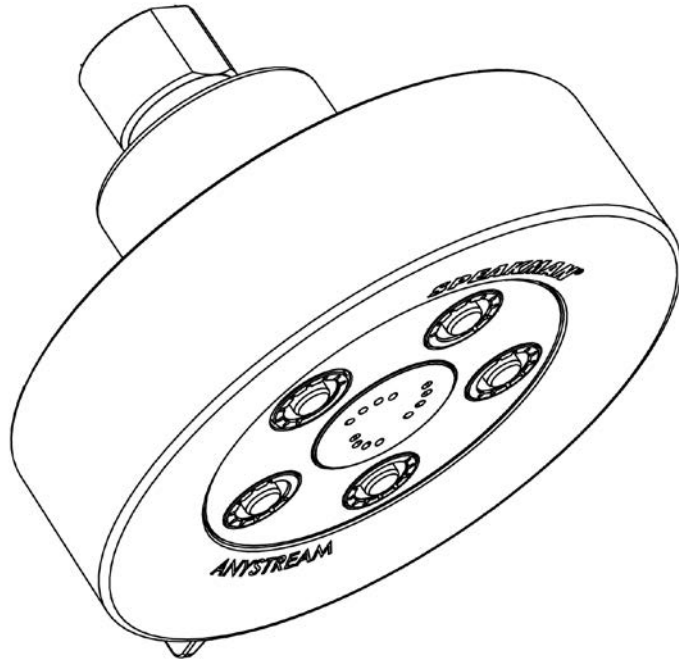

### FEATURES:

- 50 adjustable spays
- Massage spray setting
- Modern design
- 360° spray adjusting faceplate

### AVAILABLE FINISHES:

ADD SUFFIX TO MODEL #

- Polished Chrome (standard)
- Brushed Nickel  -BN
- Polished Nickel  -PN

### COMPLIANCE:

- Certified to ASME A112.18.1/CSA B125.1 standards
- WaterSense certified (E2)



### OPTIONS:

- 2.0 gpm (7.6 L/min) flow rate  -E2

### WARRANTY:

- 1 year limited

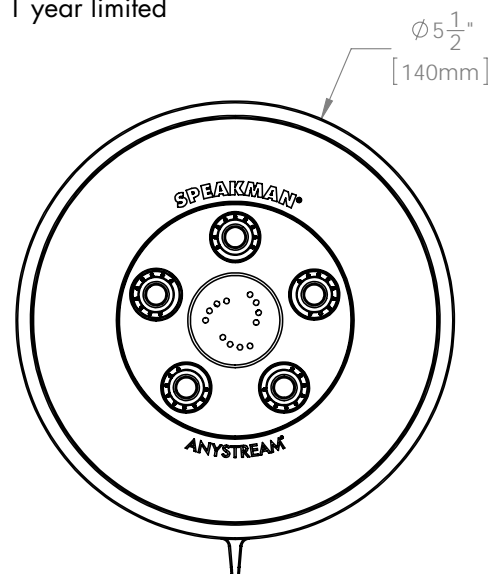
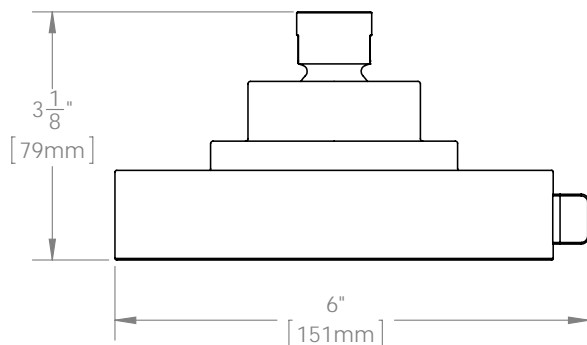

NOTE: 1. All dimensions are in inches (millimeters) unless otherwise specified and are subject to change without notice.

THIS SPACE FOR ARCHITECT/ENGINEER APPROVAL.

# SPEAKMAN®

400 ANCHOR MILL ROAD | NEW CASTLE, DE 19720  
P: 800-537-2107 | F: 800-977-2747  
WWW.SPEAKMANCOMPANY.COM

REVISION DATE: MAY 2013

Management Systems  
Registered to ISO 9001