



Valves, Automation & Controls

# **SERIES 84/99** **& FS84/FS99**



*HIGH PERFORMANCE 3-PIECE BALL VALVE  
REDUCE & FULL PORT, STANDARD & FIRE SAFE*

**SMITH-COOPER**  
INTERNATIONAL

# Design & Features

## 3-Piece Design

In-line serviceable swing-out center section allows easy access to internal valve components without disturbing alignment of pipe.

## Stem Design

Live loaded, bottom entry, blowout proof anti-static stem features packing that extends valve cycle life over conventional ball valves and is the best choice for actuation.

## Fully Encapsulated Body Seals

A tongue and groove design between the body and the end cap aligns the pipe end with the ball.

## ISO 5211 Integral Mounting Pad

Ideal for actuation. Centering lip feature assures precise alignment of bracket, stem and coupler. Actuators may be retrofitted on existing Series 84 without disruption of line integrity. Allows for secondary containment unit to be added when necessary.

## Lockable Handle

Series 84/99 Valves come standard with locking device.

## Slotted Seat Design

Relief slots help equalize body pressure, reduce torque and assure leak-tight sealing. Seats also provide a wiping action that cleans ball and seats each time valve is cycled.

## Choice of Seats and Seals

A wide variety of seat and seal materials are readily available for the most demanding applications, including Buna, Delrin, Nova\*, PEEK, EPDM, Viton®, TFE, RTFE, TFM®, Grafoil, and UHMWPE.

## Variety of End Combinations

A wide choice of optional end connections are available including, but not limited to threaded ends, socket weld ends, butt weld ends, flush bottom tank pads, flanged ends.

## Encapsulated Body Bolts

Heavy duty stainless steel bolting is protected from outside environment assuring valve integrity.

## Traceability

Heat numbers are provided on all valve bodies and ends. CMTR's (certified mill test reports) are available upon request.

## Parts & Materials

Series 84 - 3" - 4"  
Series 99 - 2½" - 3"

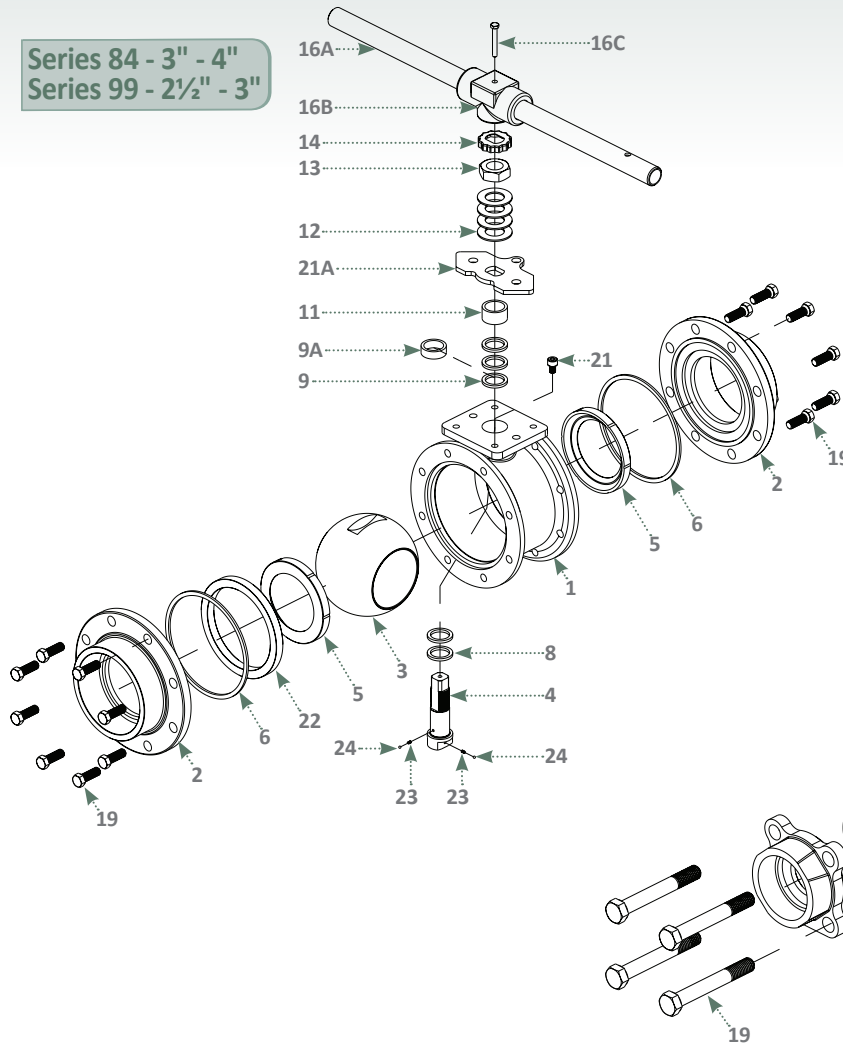

Series 84 - ¼" - 2½"  
Series 99 - ¼" - 2"

Series 84 - 2 1/2" uses wrench & wrench block, Series 99 - 2" uses wrench & wrench block

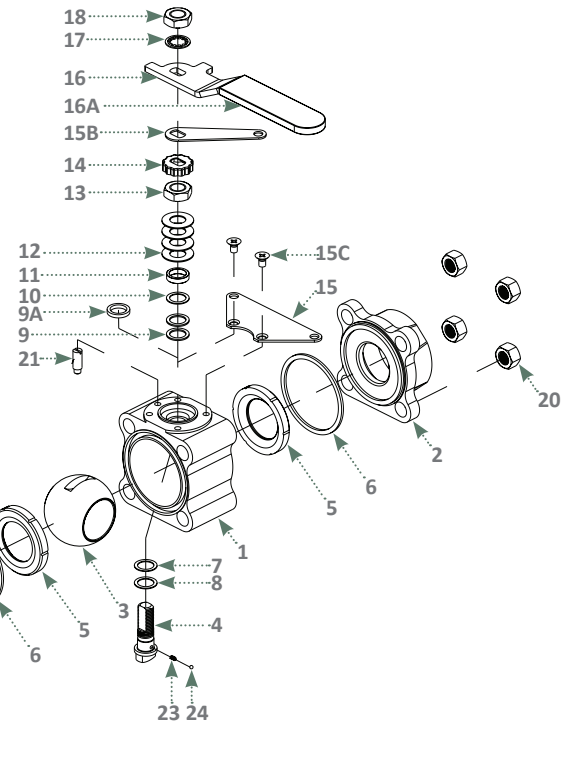

PART NO.	PART	QTY.	MATERIAL
1	Body	1	316 Stainless Steel ASTM A351 CF8M Carbon Steel ASTM A216 WCB Alloy 20 ASTM A351 CN7M Hastelloy C ASTM A494 Gr. CW-12MW
2	Ends Cap	2	316L Stainless Steel ASTM A351 CF3M Carbon Steel ASTM A216 WCB Alloy 20 ASTM A351 CN7M Hastelloy C ASTM A494 TYPE CW-12MW
3	Ball	1	316 Stainless Steel Alloy 20 Hastelloy C
4	Stem	1	316 Stainless Steel 17-4PH Alloy 20 Hastelloy C
5	Seat	2	PTFE RTFE TFM Nova UHMWPE Viton Delrin
6	Body Seal	2	PTFE Graphite Buna UHMWPE Viton
7	Thrust Bearing	1	Nova (UHMWPE with UHMWPE Seats)
8	Thrust Bearing	1	PEEK (UHMWPE with UHMWPE Seats)
9	Stem Packing	2	Nova (UHMWPE with UHMWPE Seats)
9A	Stem Packing	1-2	Graphite
10	Seal Protector	1	PEEK

PART NO.	PART	QTY.	MATERIAL
11	Gland	1	300 Series Stainless Steel
12	Belleville Washer	4	300 Series Stainless Steel
13	Packing Nut	1	300 Series Stainless Steel
14	Lock Tab	1	300 Series Stainless Steel
15	Lower Lock Latch	1	300 Series Stainless Steel
15B	Upper Lock Latch Bolt	1	300 Series Stainless Steel
15C	Latch Bolt	1	300 Series Stainless Steel
16	Handle (¼"-2")	1	300 Series Stainless Steel
16A	Wrench (3" & 4")	1	Galvanized
16B	Wrench Block	1	300 Series Stainless Steel
16C	Hex Head Bolt	1	300 Series Stainless Steel
17	Lock Washer	2	300 Series Stainless Steel
18	Handle Nut (¼"-2")	1	300 Series Stainless Steel
19	Body Bolts	4	304 Stainless Steel
20	Nuts	4	316 Stainless Steel
21	Stop Pin	1	300 Series Stainless Steel
21A	Stopper	1	300 Series Stainless Steel
22	Seat Retainer	1	300 Series Stainless Steel Carbon Steel
23	Anti-Static Spring	1	Hard Drawn Stainless Steel
24	Anti-Static Ball	1	300 Series Stainless Steel

# Dimensions

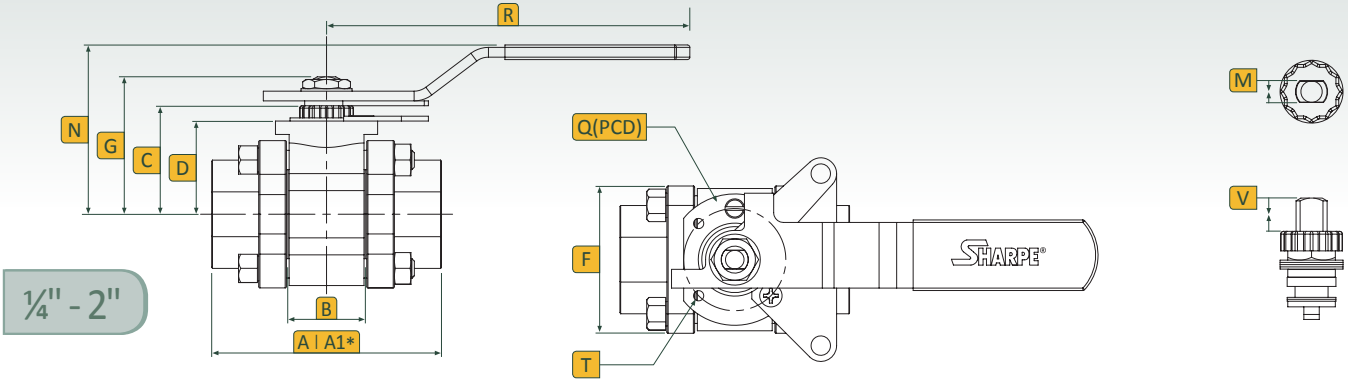

1/4" - 2"

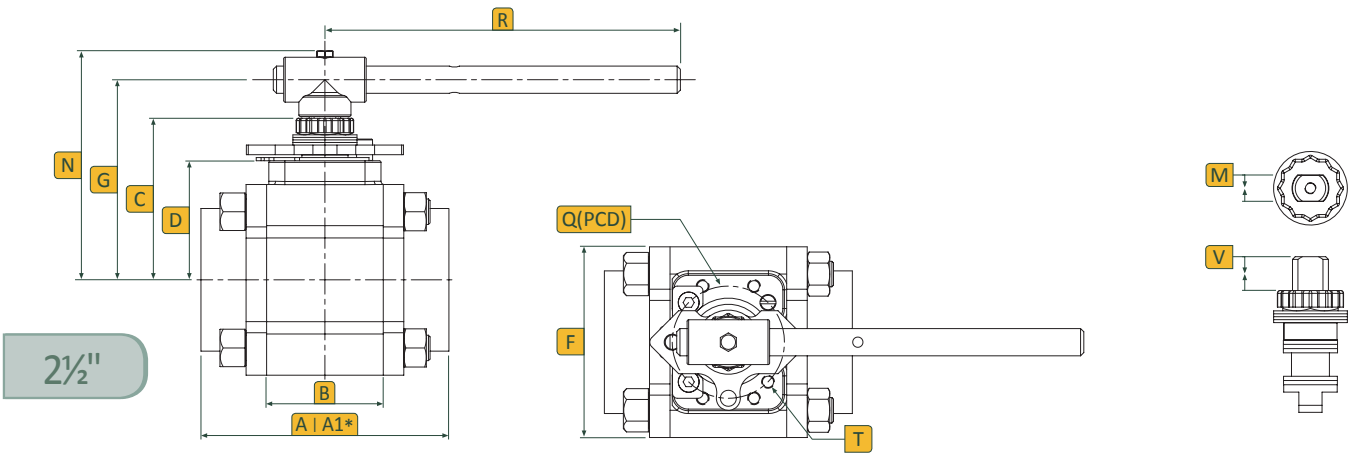

2 1/2"

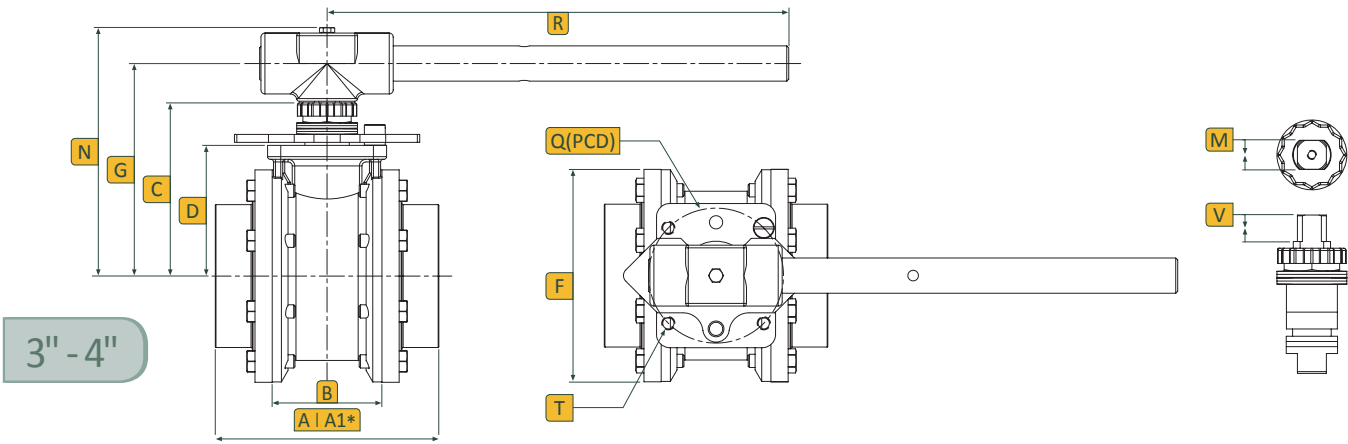

3" - 4"

84 Reduce port / 99 Full port

84	99	A*	A1*	B	C	D	F	G	L	M	N	ø Q (ISO)	R	T	V
1/4", 3/8", 1/2"	1/4", 3/8"	2.62	2.62	0.82	1.22	1.06	1.81	1.58	3/8"-24 UNF	0.220	2.15	1.42 (F03)	4.53	M5 x PO.8	0.34
3/4"	1/2"	2.87	2.87	0.97	1.27	1.13	1.94	1.65	3/8"-24 UNF	0.220	2.28	1.42 (F03)	4.53	M5 x PO.8	0.39
1"	3/4"	3.72	3.72	1.25	1.73	1.51	2.38	2.23	1/2"-20 UNF	0.295	2.70	1.65 (F04)	5.79	M5 x PO.8	0.52
1 1/4"	1"	4.25	4.25	1.61	1.90	1.70	2.78	2.43	1/2"-20 UNF	0.295	2.89	1.65 (F04)	5.79	M5 x PO.8	0.53
1 1/2"	1 1/4"	4.58	4.50	1.90	2.17	1.73	3.12	2.90	3/4"-18 UNF	0.342	3.15	1.97 (F05)	6.78	M6 x P1.0	0.73
2"	1 1/2"	5.03	5.06	2.21	2.39	1.90	3.60	3.09	3/4"-18 UNF	0.342	3.37	1.97 (F05)	6.78	M6 x P1.0	0.73
2 1/2"	2"	5.88	5.87	2.87	3.98	2.85	4.77	4.88	M20 x P2.5	0.551	5.61	2.75 (F07)	8.73	M8 x P1.25	0.74
3"	2 1/2"	6.65	6.65	3.27	5.01	3.89	6.46	6.14	1" - 14 UNS	0.748	6.14	4.02 (F10)	13.74	M10 x P1.5	0.69
4"	3"	8.43	8.43	4.29	5.60	4.48	8.00	6.73	1" - 14 UNS	0.748	7.81	4.02 (F10)	13.74	M10 x P1.5	0.69

\* A - 84 Face to Face dimenson for threaded, butt weld & socket weld ends | \* A1 - 99 Face to Face dimenson for threaded, butt weld & socket weld ends

# Technical Information

Pressure-Temperature Ratings Series 84/99

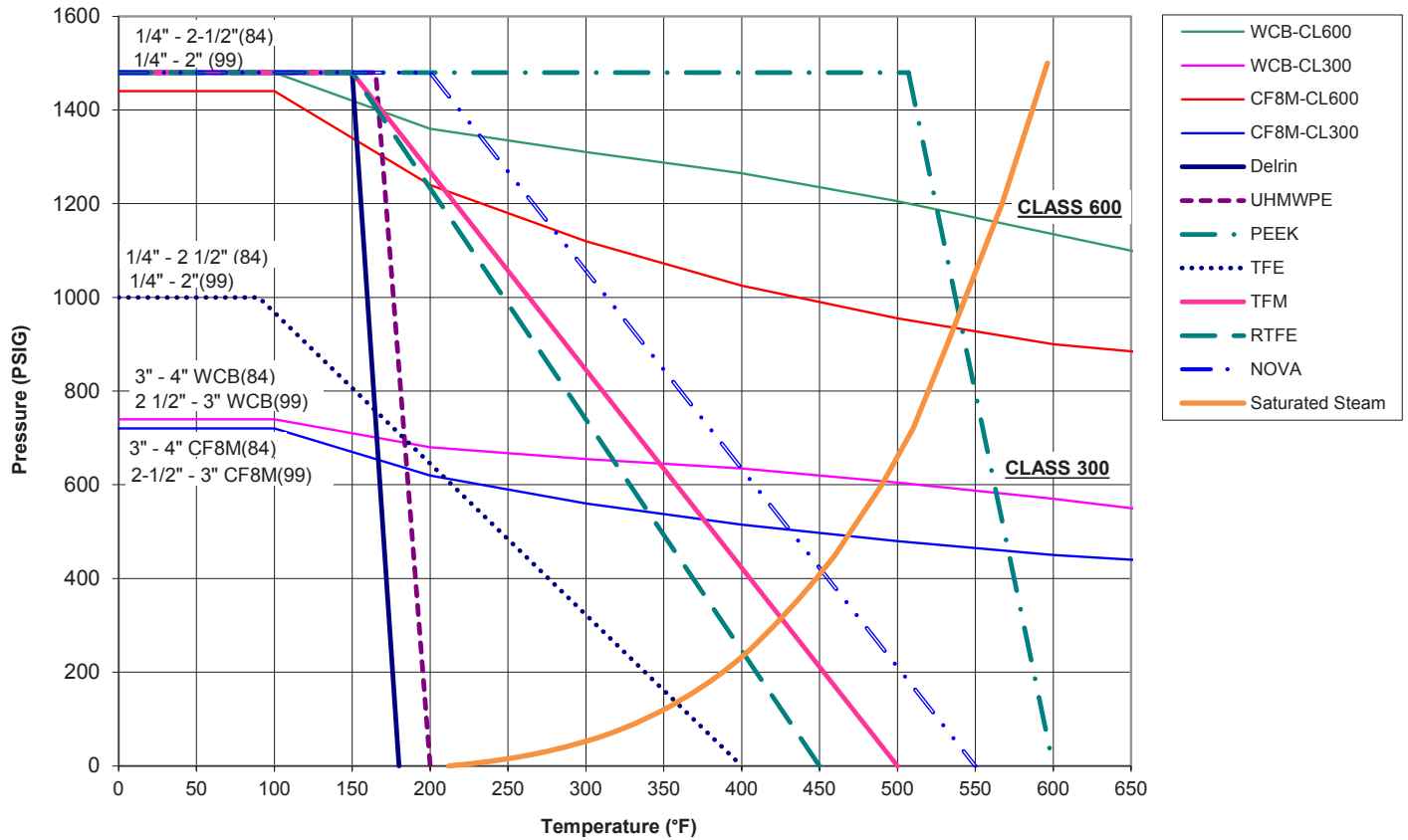

Note:  
 The maximum pressure/temperature ratings of the valve assemblies are limited to lowest of the body or seat material fitted.  
 The valve body ratings are based on ASME B16.34 rating for materials.  
 The graphs are based on laboratory testing and our experience in field.  
 The seat ratings depend on the material, design, application and function.  
 For higher pressure rating above 1,480 psig, please consult with Sharpe Valves.

Performance Data

84	99	Cv Flow Coefficient	Equivalent Length of Pipe (Feet)	Approx. Weight (lbs.)	Port Size
1/4"		8	1.9	1.20	.44
3/8"	1/4"	8	1.9	1.20	.44
1/2"	3/8"	8	1.9	1.20	.44
3/4"	1/2"	12	6.3	1.70	.56
1"	3/4"	32	3.1	3.00	.81
1 1/4"	1"	46	6.3	4.00	1.00
1 1/2"	1 1/4"	80	4.3	6.00	1.25
2"	1 1/2"	120	7.5	8.00	1.50
2 1/2"	2"	240	5.00	25.00	2.00
3"	2 1/2"	350	8.3	30.00	2.50
4"	3"	720	10.4	50.20	3.25

1. Delrin and UHMWPE seats should not be used for steam service.
2. Delrin must not be used in Oxygen applications.

Applicable Standards	
Body Wall Thickness	ASME B16.34
SW & Threaded Ends	ASME B16.11
Butt-weld Ends	ASME B16.25
Flange Dimensions	ASME B16.5
Basic Design	ASME B16.34 (note 1)
Testing (Options)	ASME B16.34 API 598

Note 1: When specified, valves can be furnished in accordance with ASME B16.34 requirements.



# How To Order Series 84/99 & FS84-FS99

<b>1"</b> Size	<b>FS84</b> Series	-	<b>2</b> Body&Ends	<b>2</b> Ball & Stem	<b>R</b> Seat	<b>G</b> Seal	-	<b>TE</b> Ends	-	<b>OH</b> Options
<b>Valve Size</b>	<b>Valve Series</b>		<b>Body &amp; Ends</b>		<b>Seat</b>	<b>Body Seal</b>		<b>Ends</b>		<b>Options</b>
¼"	84 Standard Port		2 Alloy 20		T* PTFE	G Graphite-Impregnated		TE Threaded Ends (NPT)		OH Oval Handle (up to 2")
⅜"	99 Full Port		4* Carbon Steel		R* RTFE	M TFM®		SW Socket Weld		L Lockable Ext. Stem
½"	FS84 Fire Safe		5 Hastelloy C		M* TFM®	T PTFE		BW10 Buttweld SCH 10*		SF Silicone Free (as per MFG's standards)
¾"	FS99 Fire Safe		6* 316 Stainless Steel		U Delrin®	U UHMWPE		BW40 Buttweld SCH 40		A NACE
1"					N* Nova	V Viton®		BW80 Buttweld SCH 80*		VB Vented Ba ll
1¼"					P Virgin PEEK			1 150# Flanged RF		X Oxygen Clean
1½"					U UHMWPE			3 300# Flanged RF		
2"								TP Flush Bottom Tank Pad		
2½"										
3"										
4"										
			<b>Ball &amp; Stem</b>							
			2 Alloy 20							
			5 Hastelloy C							
			6 316 Stainless Steel							
			17-4PH Stem / 316 Stainless Steel Ball							

\* Items approved for fire safe valves | Viton® is a registered trademark of E.I. DuPont. TFM is a registered trademark of Dyneon, LLC



SMITH-COOPER®  
INTERNATIONAL

