



**Safety Technology
International, Inc.**

UB-2 2" Universal Button

UB-2/LTUL Universal Button with Latching Timer



ADA
for operation

For UB-2/LTUL the enclosed timer is to be used and installed per the enclosed LT-1UL installation sheet. For access control installations, power for the LT-1UL Timer must be supplied by a power source listed to UL294. When used for access control, this device shall be used as part of an access controlled egress door system. It is up to the local AHJ to allow use of this device in place of an automatic sensor. For higher security installations, lower time limits should be used.

Pour les modèles UB-2/LTUL, la minuterie intégrée doit être installée et utilisée suivant la fiche d'installation LT-1UL fournie. Pour les installations de contrôle d'accès, l'alimentation de la minuterie LT-1 doit être fournie par une source homologuée UL294. Lorsque cet appareil est utilisé aux fins de contrôle d'accès, il doit faire partie d'un système de porte de sortie à accès contrôlé. Il incombe donc à l'AHJ local d'autoriser l'utilisation de cet appareil au lieu d'un capteur automatique. Pour les installations de sécurité plus renforcée, des délais inférieurs doivent être utilisés.

We protect the things that protect you.

NOTES

It is important to read, understand and follow all instructions provided with this product. It is the installer's responsibility to comply with NFPA 70 & 101, NEC, mounting specifications according to ADA and other applicable electrical codes. For Type SM (Self Monitored) rating, the term Emergency message may be installed on Model UB-1 when used in a system with a Listed, compatible Releasing Device. All other applications are rated Type NM (Non-Monitored) for non-emergency signaling. To avoid electrical shock, DO NOT attempt to install this product when power is on. ADA mounting compliance requires the operable part of the initiating device shall not be less than 3 1/2 ft. (1.1m) or greater than 4 1/2 ft. (1.37m) above finished floor surface. After installation and testing are complete, provide a copy of this manual to all personnel responsible for testing and maintenance of this product.

REMARQUES

Il est important de lire, de comprendre et de suivre toutes les instructions fournies avec ce produit. Il incombe à l'installateur de se conformer aux normes NFPA 70 et 101, NEC, aux spécifications de montage selon l'ADA et aux autres codes de l'électricité en vigueur. Pour les cotes de type SM (auto surveillée), le message d'Urgence peut être apposé sur le modèle UB-1 lorsqu'il est utilisé dans un système intégrant un dispositif de déclenchement compatible et homologué. Toutes les autres applications sont cotées de Type NM (non surveillée) pour la signalisation non urgente. Pour éviter un choc électrique, NE tentez PAS d'installer ce produit lorsqu'il est sous tension. La conformité aux règles d'installation de l'ADA exige que la partie utilisable du dispositif de déclenchement soit installée à une hauteur située entre 3 1/2 pi (1,1 m) et 4 1/2 pi (1,37 m) au-dessus du plancher fini. Une fois l'installation et les essais terminés, vous devez fournir une copie de ce manuel à l'ensemble du personnel chargé de l'essai et de l'entretien de ce produit.

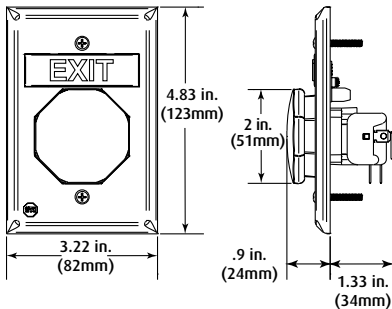

SWITCH RATING

2 Independent Form "C" contacts
UB-2 rated at: 10A, 1/2 HP, 125/250 VAC
6A, 30 VDC

100,000 Operations

Temperature: -40° to 185°F (-40° to 85°C)

Model UB-2/LTUL

Form C contacts on timer rated:
30 VDC 3A, 1.0 pf

1 TO CHANGE BUTTON COLOR AND ROUND MESSAGE

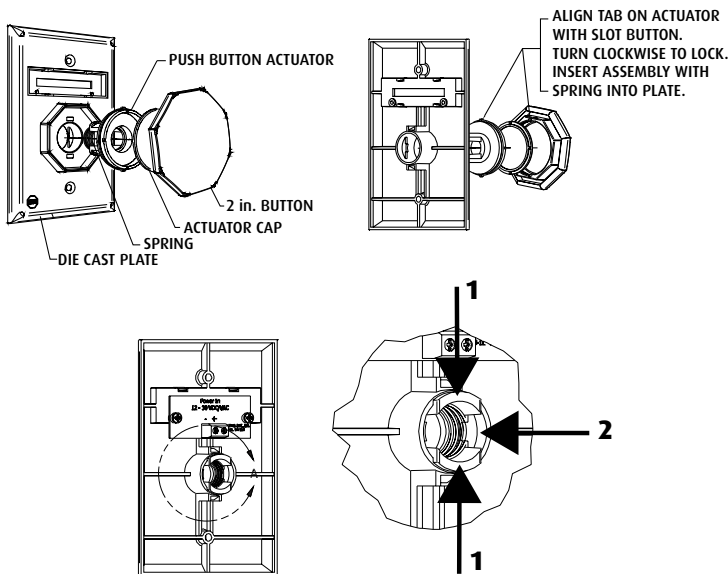

1. Choose button message and color. If same as existing, proceed to **2**
2. To remove push button actuator assembly, squeeze actuator tabs in direction of #1 arrows.
3. Push actuator through plate in direction of #2 arrow.
4. Align actuator cap to push button actuator. Align button slots to tabs on push button actuator.
5. Snap button onto push button actuator and rotate right to lock.
6. Insert spring into push button actuator.
7. Squeeze legs of push button actuator and align into die cast plate.

2 CHANGE TOP MESSAGE

Refer to notes on pg. 2 for "EMERGENCY" message use.

1. Remove LED circuit board.
2. Remove current message by pushing in and down on tabs 1 and 2 with a small screwdriver. If necessary, also push in and down on tabs 3 and 4. Once message is loose, remove from the front of the plate.
3. Select new message and snap into place. Blank plates are included to create your own custom message.

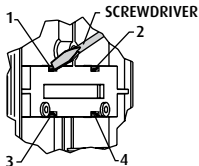
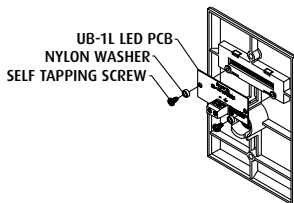

3 INSTALL OR REMOVE CONTACT BLOCK

INSTALL

To attach, align tabs (as shown) and gently snap **top, then bottom**. Be sure to hear **BOTH** tabs snap into place. (Can be reversed if wiring comes from the top of the box.)

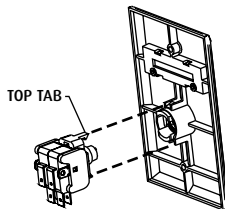

REMOVE

Repeat **STEP A** for the top and bottom tab before removing contact block.

Step A: Position small flat screwdriver blade under tab and gently rotate until tab disengages. The contact block will rotate a little. Do **NOT** pull yet.

Step B: Repeat for opposite tab.

Step C: When both tabs are disengaged, pull the contact block straight off.

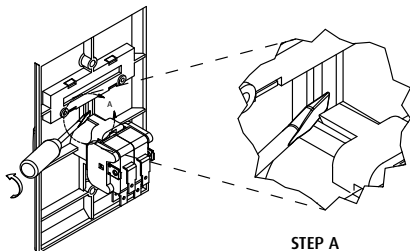

STEP A

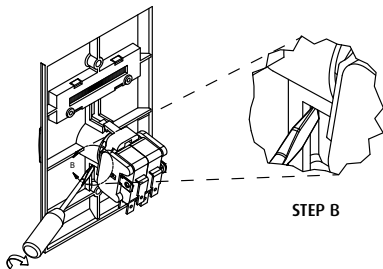
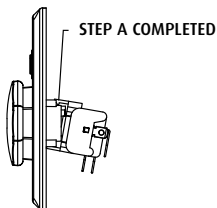

STEP B

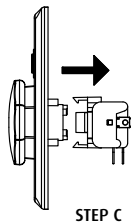

4 ATTACH POWER FOR LED (IF DESIRED)

(See drawing)

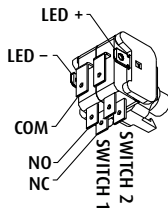
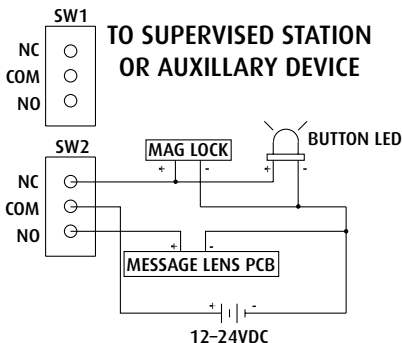

	<u>NORMAL POSITION</u>	<u>BUTTON ACTIVATED</u>
MAGNETIC LOCK	ON	OFF
BUTTON LAMP	ON	OFF
MESSAGE LAMP	OFF	ON

NOTE

LED connection: The polarity shown is factory installed. LED is polarity sensitive. If LED does not light, switch positive and negative wiring or remove LED and rotate 180°. 24 volt is included and will operate on 12 volts; however not as bright. 12 volt LED's are also available.

5 MOUNT BUTTON ONTO ELECTRICAL BOX

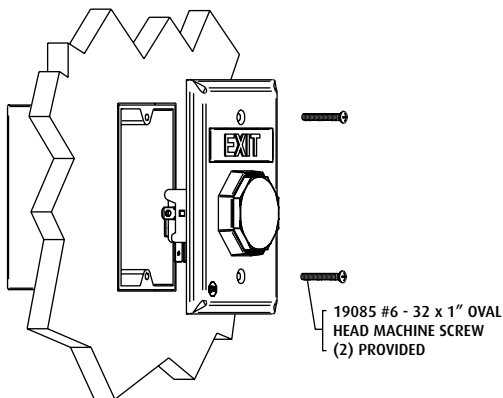

6 CUSTOM LABELS

To create your own custom label, size to fit in .48h x 2.23w area as shown below.

Also available online at: www.sti-usa.com/ublabel

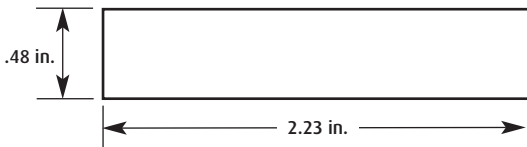

WARRANTY

Three year guarantee against breakage of polycarbonate in normal use (one year on electro mechanical and electronic components).

Electronic warranty form at www.sti-usa.com/wc14.

ACCESSORIES

DESCRIPTION	PART #
CONTACT BLOCK	SUB-UB-1C
COLOR MATCH BACK BOX KIT	SUB-71100A - COLOR (red, blue, green, white or yellow)
CUSTOM LABEL APPLIED TO BLANK MESSAGE PLATES	UB-1CL-COLOR (blue, green, white or yellow)
<u>24 VOLT LED</u>	
WHITE (STANDARD)	10147
RED	10145
BLUE	10141
GREEN	10143
<u>12 VOLT LED</u>	
RED	10144
BLUE	10140
GREEN	10142
<u>COVERS</u>	
BOPPER STOPPER	STI-6518
UNIVERSAL STOPPER	STI-13000 Series
STOPPER II	STI-1100 Series
See website for complete cover details	



Safety Technology International, Inc.

2306 Airport Rd • Waterford, MI 48327
Phone: 248-673-9898 • Fax: 248-673-1246
info@sti-usa.com • www.sti-usa.com

Safety Technology International (Europe) Ltd.

Unit 49G Pipers Road • Park Farm Industrial Estate • Redditch
Worcestershire • B98 0HU • England • Tel: 44 (0) 1527 520 999
Fax: 44 (0) 1527 501 999 • Freephone: 0800 085 1678 (UK only)
E-mail: info@sti-europe.com • Web: www.sti-europe.com

