



**Safety Technology
International, Inc.**

UB-1PN Universal Pneumatic Button



ADA
for operation

We protect the things that protect you.

NOTES

It is important to read, understand and follow all instructions provided with this product. It is the installer's responsibility to comply with NFPA 70 & 101, NEC, mounting specifications according to ADA and other applicable electrical codes. To avoid electrical shock, DO NOT attempt to install this product when power is on. ADA mounting compliance requires the operable part of the initiating device shall not be less than 3 1/2 ft. (1.1m) or greater than 4 1/2 ft. (1.37m) above finished floor surface. After installation and testing are complete, provide a copy of this manual to all personnel responsible for testing and maintenance of this product.

* For access control installations, power for the UB-1PN must be supplied by a power source Listed to UL294. When used for access control, this device shall be used as a part of an access controlled egress door system. It is up to the local AHJ to allow use of this device in place of an automatic sensor. For higher security installations, lower time limits should be used.

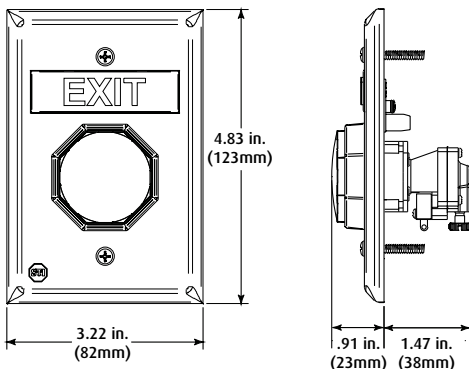

SWITCH RATING Independent Form "Z" contacts

Rated at: 10A @ 240 VAC

Operating Temp: 15° to 120°F (-9° to 49°C)

1,000,000 Cycles

1 TO CHANGE BUTTON COLOR AND ROUND MESSAGE

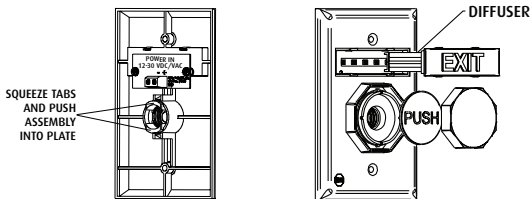

1. Choose button message and color. If same as existing, proceed to **2**
2. If choosing a new message, remove button. On the back side of the plate, squeeze tabs and push actuator assembly into plate just enough to grasp the button and remove.
3. From the front of the plate, push actuator back into original position.
4. Choose button message. Blank plate is available for your custom message.
 - a. Insert button message, align 4 notches on actuator.
 - b. Select color lens. Align top and bottom notches with tabs on actuator and push until it snaps together.

2 CHANGE TOP MESSAGE

1. Remove LED circuit board.
2. Remove current message by pushing in and down on tabs 1 and 2 with a small screwdriver. If necessary, also push in and down on tabs 3 and 4. Once message is loose, remove from the front of the plate.
3. Select new message and snap into place. Blank plates are included to create your own custom message.

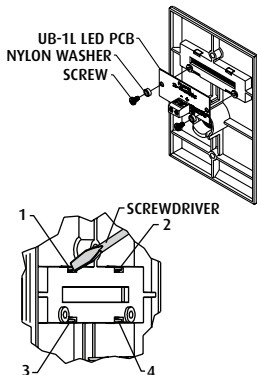

3 INSTALL OR REMOVE CONTACT BLOCK

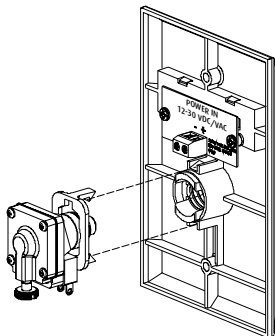

CONTACT INFORMATION

INSTALL

To attach, align tabs (as shown) and gently snap **top, then bottom**. Be sure to hear **BOTH** tabs snap into place. Contacts can be rotated 180° if desired.

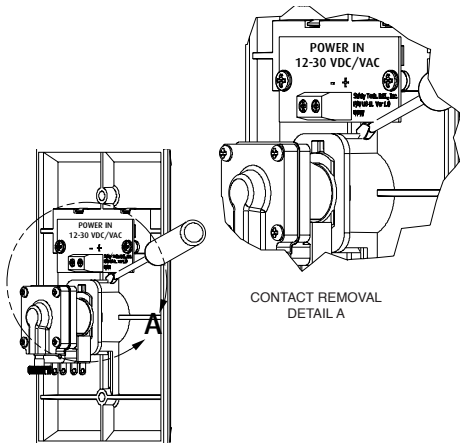

CONTACT REMOVAL
DETAIL A

REMOVE

To remove, use a small flat blade screwdriver. Position screwdriver blade under tab and gently rotate screwdriver until tab disengages. Repeat for opposite tab.

4 ATTACH POWER FOR LED (IF DESIRED)

(See drawing)

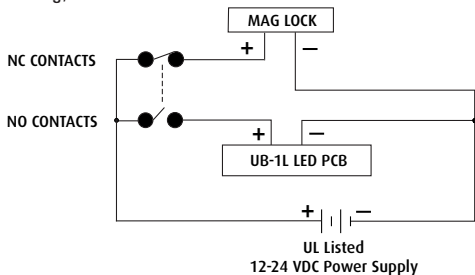

	<u>NORMAL POSITION</u>	<u>BUTTON ACTIVATED</u>
MAGNETIC LOCK	ON	OFF
MESSAGE LAMP	OFF	ON

CONTACT DIAGRAM

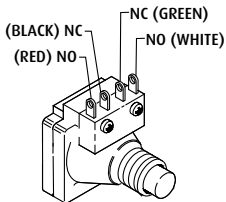

CONTACTS
One set NO and one set NC

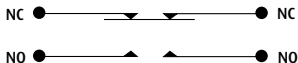

SWITCH INFORMATION

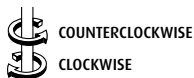

TIMER RANGE ADJUSTMENT SCREW
ADJUSTMENT RANGE - 2 TO 60 SECONDS

TIMER FACTORY SET TO MINIMUM TIME SETTING. TO INCREASE TIME, TURN SCREW CLOCKWISE IN 1/4 TURN INCREMENTS. WHEN CLOSE TO DESIRED TIME, TURN SCREW IN VERY FINE INCREMENTS TO DESIRED SETTING.
CAUTION: OVER-TIGHTENING MAY CAUSE DAMAGE TO TIMER.

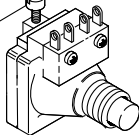

5 MOUNT BUTTON ONTO ELECTRICAL BOX

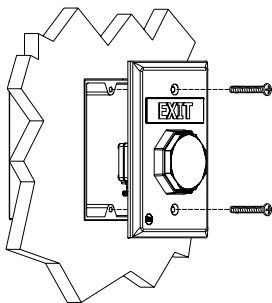

6 CUSTOM LABELS

To create your own custom label, size to fit in .48h x 2.23w as shown below.

Also available online at: www.sti-usa.com/ublabel

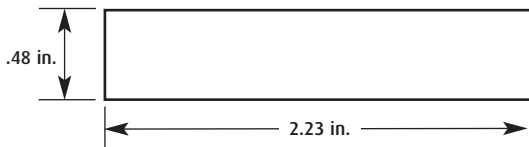

ACCESSORIES

DESCRIPTION	PART #
CONTACT BLOCK	SUB-UB-1PNC
COLOR MATCH BACK BOX KIT	SUB-71100A-COLOR (red, blue, green, white or yellow)
CUSTOM LABEL APPLIED TO BLANK MESSAGE PLATES	UB-1CL-COLOR (blue, green, white or yellow)
<u>24 VOLT LED</u>	
WHITE (STANDARD)	10147
RED	10145
BLUE	10141
GREEN	10143
<u>12 VOLT LED</u>	
RED	10144
BLUE	10140
GREEN	10142
<u>COVERS</u>	
BOPPER STOPPER	STI-6518
UNIVERSAL STOPPER	STI-13000 Series
STOPPER II	STI-1100 Series
See website for complete cover details	

WARRANTY

Three year guarantee against breakage of polycarbonate in normal use (one year on electro mechanical and electronic components).

Electronic warranty form at www.sti-usa.com/wc14.



**Safety Technology
International, Inc.**

2306 Airport Rd • Waterford, MI 48327
Phone: 248-673-9898 • Fax: 248-673-1246
info@sti-usa.com • www.sti-usa.com



Safety Technology International (Europe) Ltd.

Unit 49G Pipers Road • Park Farm Industrial Estate • Redditch
Worcestershire • B98 0HU • England • Tel: 44 (0) 1527 520 999
Fax: 44 (0) 1527 501 999 • Freephone: 0800 085 1678 (UK only)
E-mail: info@sti-europe.com • Web: www.sti-europe.com