

STI Horn/Strobe Damage Stoppers®



STI-1210B



STI-1221E



STI-1217



STI-1225



ADA
Compliant

MEA
STI-1210 AND
STI-1221 ONLY

PRODUCT OVERVIEW

These virtually indestructible covers (slotted for horn or speaker units and solid for strobe-only alarms) are designed to stop vandalism and accidental damage. Molded of clear, thick, UV-stabilized polycarbonate material, they are backed by a three year guarantee against breakage in normal use. Slots in the STI-1210, 1215, 1217 and 1219 allow the horn to be heard. The STI-1221, 1225, 1227 and 1229 are for strobes only. Many tough, clear spacers are available for larger strobe/horn units, retrofits, surface-mount and weather resistant applications. For the STI-1210/1221 series, spacer A has a four inch deep enclosed backbox, spacer B has an enclosed backbox molded with an integral double-gang outlet box. Spacer C has an open back for retrofit applications. Spacer D accommodates deeper units and applications with exposed conduit electrical connections. Spacer E has an open back frame for flush-mount applications. An appliance mounting plate comes with the STI-1219/1229. Unique Enviro Kits are available for extreme conditions where dampness or water is present.

FEATURES

- Helps prevent accidental and intentional damage or vandalism.
- Enviro Kit available for harsh conditions.
- Various backbox and spacer depths are available to accommodate special applications.
- Covers are UV-stabilized.
- See chart for light and sound loss information.
- Typical working properties of polycarbonate are -40° to 250°F (-40° to 121°C).
- Easy access for service.
- See STI-1229HTR heated Type 4X enclosure for strobes in freezing conditions.
- Three year guarantee against breakage of polycarbonate in normal use.

STI Horn/Strobe Damage Stoppers®

MODELS AVAILABLE

- STI-1210A** Horn/Strobe Damage Stopper cover and enclosed backbox, 4" deep, weather resistant
- STI-1210B** Horn/Strobe Damage Stopper cover and enclosed backbox with double-gang outlet box
- STI-1210C** Horn/Strobe Damage Stopper cover open backbox with external mounting tabs
- STI-1210D** Horn/Strobe Damage Stopper cover and open backbox with conduit knockout
- STI-1210E** Horn/Strobe Damage Stopper cover and open backbox for flush mount
- STI-1221A** Strobe Damage Stopper cover and enclosed backbox, 4" deep, weatherproof with drain vent, Type 3R
- STI-1221A4X** Strobe Damage Stopper cover and enclosed backbox, 4" deep, weatherproof, Type 4X
- STI-1221B** Strobe Damage Stopper cover and solid enclosed backbox and double-gang outlet box
- STI-1221C** Strobe Damage Stopper cover and open backbox with external mounting tabs
- STI-1221D** Strobe Damage Stopper cover and open backbox with conduit knockout
- STI-1221E** Strobe Damage Stopper cover and open backbox for flush mount
- SUB-84** Tamper resistant screws
- SUB-121** Enviro Kit for D and E models
- SUB-122** Enviro Kit for B and C models
- SUB-06297D** "D" spacer only
- SUB-06297E** "E" spacer only
- STI-1283** Backplate for "D" and "E" models
- 19038** Bit for tamper resistant screws
- SUB-6297B20** 3/4" conduit hub for "B" and "C" backbox outdoor rated)

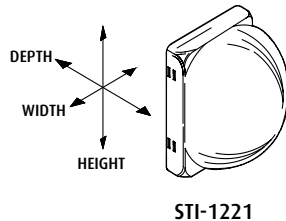
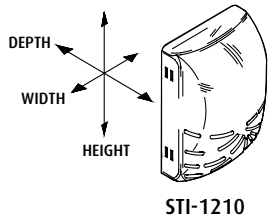

STI-1210 Series Horn/Strobe Covers				STI-1221 Series Strobe Covers		
Spacer	H	W	D	H	W	D
A	8.5 in. (216mm)	6.5 in. (165mm)	6.25 in. (159mm)	8.5 in. (216mm)	6.5 in. (165mm)	6.25 in. (159mm)
B	8.5 in. (216mm)	6.5 in. (165mm)	3.5 in. (89mm)	8.5 in. (216mm)	6.5 in. (165mm)	3.5 in. (89mm)
C	8.5 in. (216mm)	6.5 in. (165mm)	4.75 in. (120mm)	8.5 in. (216mm)	6.5 in. (165mm)	4.75 in. (120mm)
D	8.5 in. (216mm)	6.5 in. (165mm)	5.75 in. (146mm)	8.5 in. (216mm)	6.5 in. (165mm)	5.75 in. (146mm)
E	8.5 in. (216mm)	6.5 in. (165mm)	4 in. (102mm)	8.5 in. (216mm)	6.5 in. (165mm)	4 in. (102mm)

APPROVALS & WARRANTY

TESTING

- It has been tested and approved or listed by:
 - Underwriter Laboratories and Canadian UL File S7025
 - cUL approval for UL 1638 only
 - CSFM needs local approval
 - MEA STI-1210 and STI-1221 series only
 - UL Listed for fire voice speakers for STI-1210 series only
 - ADA Compliant

WARRANTY

Three year guarantee against breakage of polycarbonate in normal use.

Performance Review Manufacturer

STI-1210 SERIES	Light Loss %
ADT SECURITY (ADTG1-V Series), EST/EDWARDS(G1-V Series, G1-HV Series, G1-HOV Series, EG1-V Series, EG1-HV Series, EG1-HOV Series), HONEYWELL (XLSG1-V, XLSG1-HV, XLSG1-HOV Series), MIRCOM (MG1-V, MG1-HV, MG1-HOV Series), SIEMENS (G1-V Series), ZITON PTY LTD (ZG1-V Series)	40%
EST/EDWARDS (2440S, 202 Series), HONEYWELL (XLS202 Series), MIRCOM (MS Series), MIRTONE (MG1-V Series), SIEMENS (202 Series)	43%
AMSECO-(SL24W-153075 CLEAR, A, B, G or R, SL24C-3075110 A, B, G or R, CSL24W-A, B, G or R, CSL24C-A, B, G or R), MIRCOM (FS-240), POTTER ELECTRIC (AS-24-153075R, AS-24-153075W)SYSTEM SENSOR (SS24110ADA)	47%
SYSTEM SENSOR (P2, PC2, P4, PC4, SX, SC)	53%
STI-1221 SERIES	
AMSECO-(SL24W-153075 CLEAR, A, B, G or R, SL24C-3075110 A, B, G or R, CSL24W-A, B, G or R, CSL24C-A, B, G or R), MIRCOM (FS-240), POTTER ELECTRIC (AS-24-153075R, AS-24-153075W)	26%
DETECTION SYSTEMS (GES24 Series), GENTEX (GES24 Series), HARRINGTON SIGNAL (GES24 Series), NATIONAL TIME & SIGNAL (GES24 Series), SECUTRON (GES24 Series)	31%
ADT SECURITY (ADTG1-V Series), EST/EDWARDS (G1-V Series, G1-HV Series, G1-HOV Series, EG1-V Series, EG1-HV Series, EG1-HOV Series), HONEYWELL (XLSG1-V Series, XLSG1-HV Series, XLSG1-HOV Series), MIRCOM (MG1-V, MG1-HV, MG1-HOV Series), SIEMENS (G1-V Series), ZITON PTY LTD. (ZG1-V Series)	34%
AMSECO (SL24W-153075), SYSTEM SENSOR (SS24110ADA)	37%
EST/EDWARDS (2440S, 202 Series), HONEYWELL (XLS202 Series), MIRCOM (MS Series), MIRTONE (MG1-V Series), SIEMENS (202 Series)	45%
FARADAY LLC (2700)	57%
SYSTEM SENSOR (P2, PC2, P4, PC4, SX, SC)	61%

Use of horn/strobe cover on audible device decreases the sound output by 6dB(A).

SPACER

DESCRIPTION

- A** Enclosed backbox, 4" deep (includes neoprene gasket)
- A4X** Enclosed backbox, 4" deep Type 4X (includes silicone gasket)
- B** Enclosed backbox with double-gang outlet box
- C** Open backbox with external mounting tabs
- D** Open backbox with conduit knockout
- E** Open backbox for flush mount

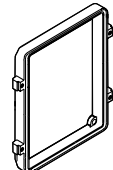
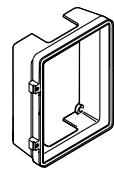
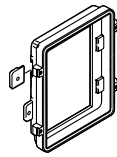
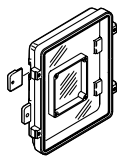
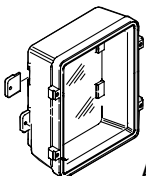

STI Stopper® Dome

Dimensions and Technical Information

MODELS AVAILABLE

- STI-1215** Stopper Dome for Horn/ Speaker/Strobe for flush mount
- STI-1217** Stopper Dome for Horn/ Speaker/Strobe with open backbox
- STI-1219** Stopper Dome for Horn/ Speaker/Strobe with enclosed backbox
- STI-1225** Stopper Dome for Strobe only flush mount
- STI-1227** Stopper Dome for Strobe only with open backbox
- STI-1229*** Stopper Dome for Strobe only with enclosed backbox, Type 4X

- STI-1212** Spacer kit
- STI-1222** Enclosed backbox for Stopper Dome
- STI-1284** Single Gang Mounting Adapter for STI-1219 and STI-1229

- SUB-84** Tamper resistant screws
- SUB-123** Enviro Kit includes three gaskets
- 19038** Bit for tamper resistant screws

*Hazardous models available. See STI-1229.

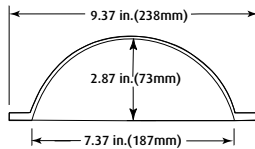

STI-1215 / STI-1225

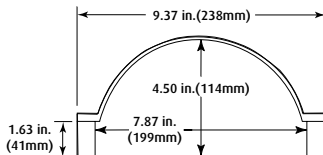

STI-1217 / STI-1227

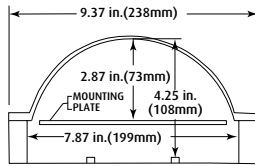

STI-1219 / STI-1229

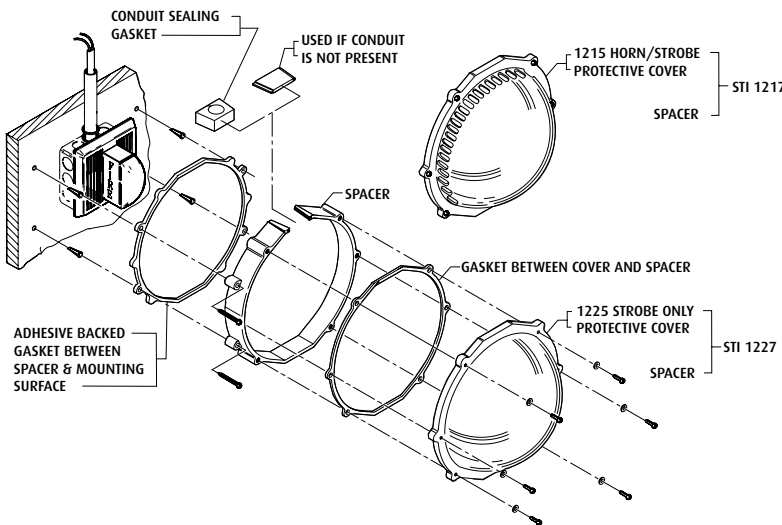

APPROVALS & WARRANTY

TESTING

- It has been tested and approved or listed by:
 - Underwriter Laboratories and Canadian UL File S7025
 - cUL approval for UL 1638 only
 - CSFM needs local approval
 - For hazardous applications in Canada, to meet cUL, your strobe must be ULC Listed
 - ADA Compliant

WARRANTY

Three year guarantee against breakage of polycarbonate in normal use.

Performance Review Manufacturer

STI-1215/17/19 SERIES	Light Loss %
ADT SECURITY (ADTG1-V Series), EST/EDWARDS (G1-V Series, G1-HV Series, G1-HOV Series, EG1-V Series, EG1-HV Series, EG1-HOV Series), HONEYWELL (XLSG1-V Series, XLSG1-HV Series, XLSG1-HOV Series), MIRCOM (MG1-V Series, MG1-HV Series, MG1-HOV Series), MIRTONE (MG1-V Series), SIEMENS (G1-V Series), ZITON PTY LTD (ZG1-V SERIES)	20%
AMSECO (SL24W-153075), AMSECO-COLORED LENSES (SL24W-153075 A, B, G or R, SL24C-3075110 A, B, G or R, CSL24W-A, B, G or R, CSL24C-A, B, G or R), MIRCOM (FS-240), POTTER ELECTRIC (AS-24-153075R, AS-24-153075W)	22%
FARADAY (2700), SIEMENS (U-MCS Series)	23%
DETECTION SYSTEMS (GES24 Series, GES24-15/75), GENTEX (GES24 Series, GES224-15/75), HARRINGTON SIGNAL (GES24 Series, GES24-15/75), NATIONAL TIME & SIGNAL (GES24 Series, GES24-15/75), SECUTRON (GES24 Series, GES24-15/75)	27%
SYSTEM SENSOR (SS24110ADA)	26%
EST/EDWARDS (2440S Series, 202 Series), HONEYWELL (XLS202 Series), MIRCOM (MS Series), SIEMENS (202 Series)	33%
WHEELOCK (RSS-24MCW)	34%
WHEELOCK (RSS-24MCC)	36%
SYSTEM SENSOR (P2, PC2, P4, PC4, SX, SC)	39%
STI-1225/27/29 SERIES	
SYSTEM SENSOR (P2, PC2, P4, PC4, SX, SC)	28%
WHEELOCK (RSS-24MCW)	31%
ADT SECURITY (ADTG1-V Series), EST/EDWARDS (G1-V Series, G1-HV Series, G1-HOV Series, EG1-V Series, EG1-HV Series, EG1-HOV Series), HONEYWELL (XLSG1-V Series, XLSG1-HV Series, XLSG1-HOV Series), MIRCOM (MG1-V Series, MG1-HV Series, MG1-HOV Series), MIRTONE (MG1-V Series), SIEMENS (G1-V Series), ZITON PTY LTD. (ZG1-V SERIES)	32%
FARADAY (2700), SIEMENS (U-MCS Series)	33%
EST/EDWARDS (2440S Series, 202 Series), HONEYWELL (XLS202 Series), MIRCOM (MS Series), SIEMENS (202 Series)	34%
WHEELOCK (RSS-24MCC)	35%
SYSTEM SENSOR (SS24110ADA)	36%
AMSECO (SL24W-153075), AMSECO-COLORED LENSES (SL24W-153075 A, B, G or R, SL24C-3075110 A, B, G or R, CSL24W-A, B, G or R, CSL24C-A, B, G or R) SCM24W), DETECTION SYSTEMS (GES24 Series, GES24-15/75), GENTEX (GES24 Series, GES224-15/75), HARRINGTON SIGNAL (GES24 Series, GES24-15/75), HONEYWELL (XLSG1-HOV Series), MIRCOM (FS-240), NATIONAL TIME & SIGNAL (GES24 Series, GES24-15/75), POTTER ELECTRIC (AS-24-153075R, AS-24-153075W), SECUTRON (GES24 Series, GES24-15/75)	37%

Sound loss for STI-1215, 1217 and 1219

Horns: Amseco Audible Horn Sounders - 6.2 dBA

Speakers: Siemens Adapter Series (0.5, 1, or 2 watt taps only) - 4.1 dBA

STI Horn/Strobe Damage Stoppers®

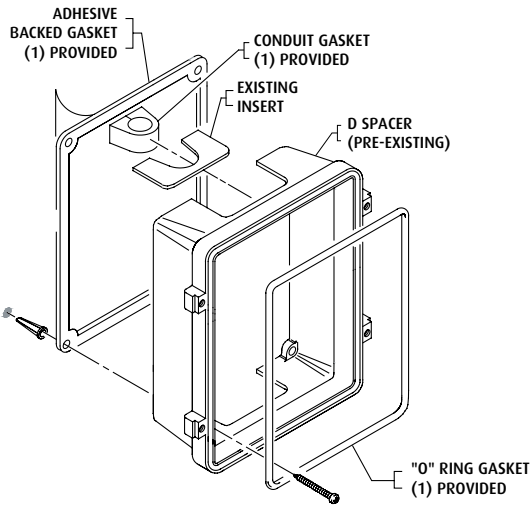

SUB-121

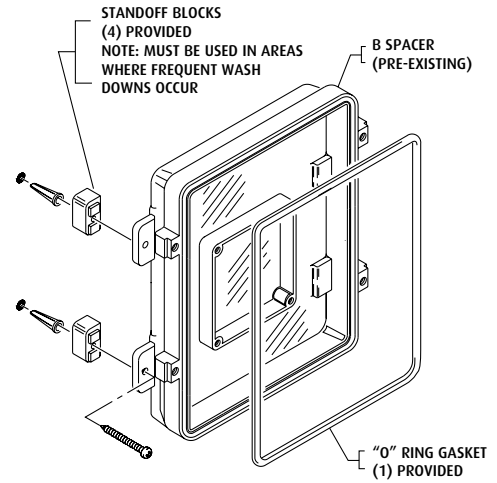

**STI-1210B
 STI-1221B**

SUB-122

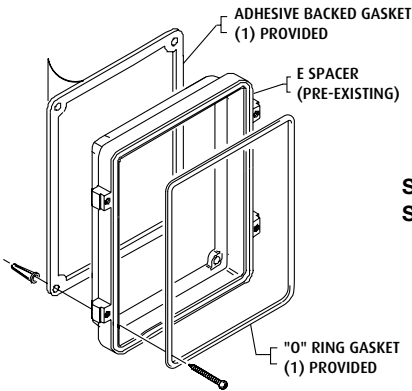

**STI-1210E
 STI-1221E**

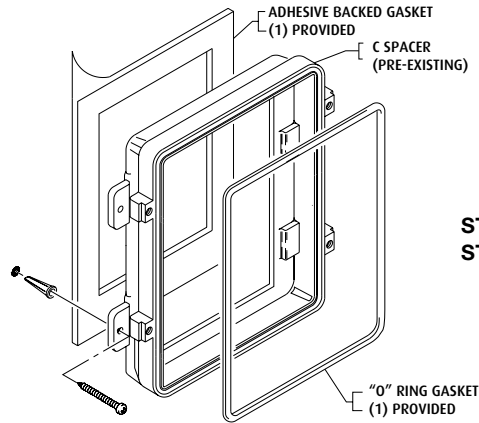

**STI-1210C
 STI-1221C**

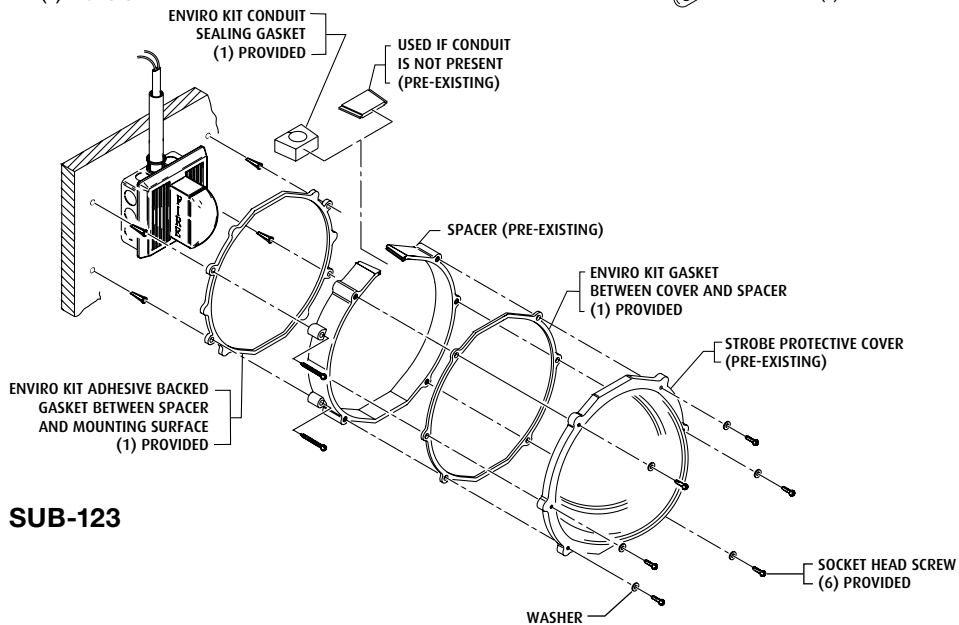

SUB-123



**Safety Technology
 International, Inc.**

2306 Airport Road
 Waterford, Michigan
 48327, USA

Tel: 248-673-9898
 Fax: 248-673-1246
 Toll-free: 800-888-4STI
 info@sti-usa.com
 www.sti-usa.com

Unit 49G Pipers Road
 Park Farm Industrial Estate
 Redditch, Worcestershire
 B98 0HU England

Tel: 44 (0) 1527 520 999
 Fax: 44 (0) 1527 501 999
 Free: 0800 085 1678 (UK)
 www.sti-europe.com