

The Wire Guard Collection

"We Protect the Things that Protect You."

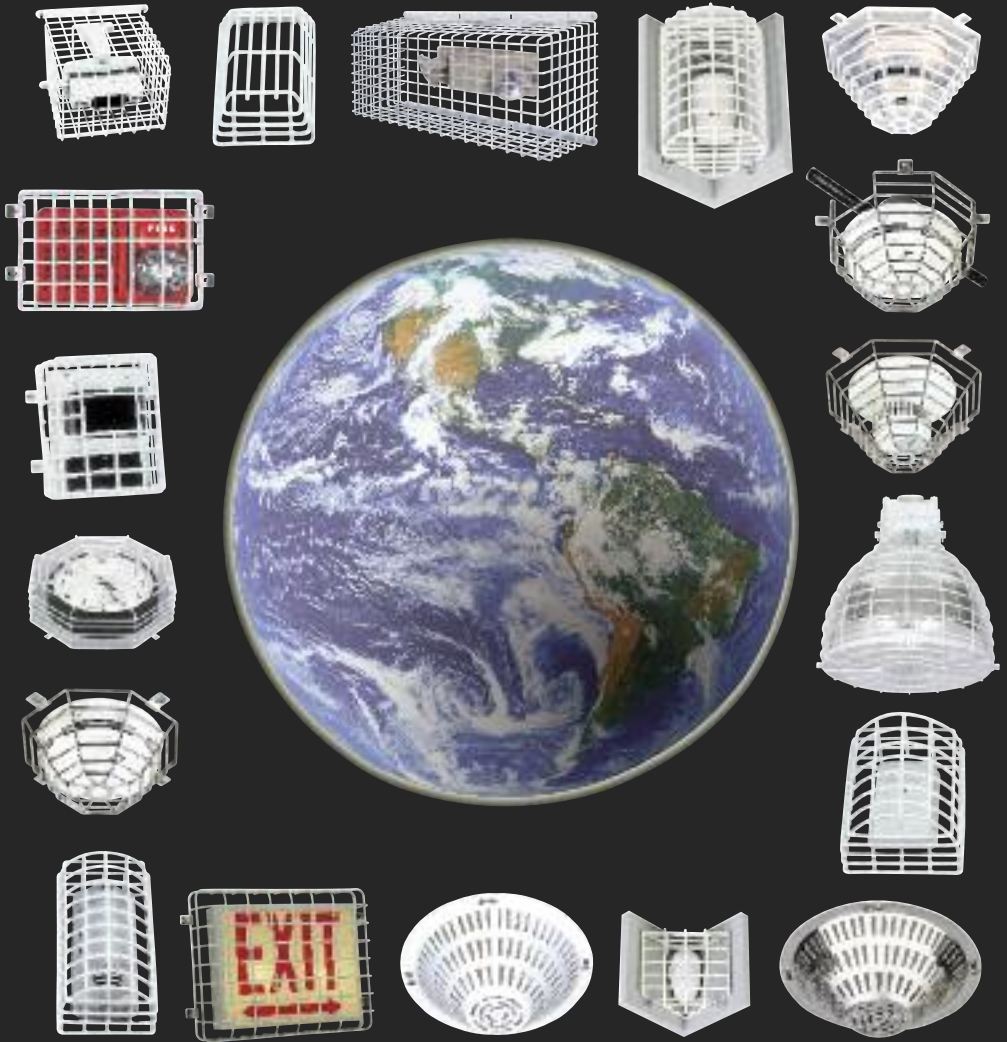

Safety Technology International, Inc.

Steel Web Stoppers®

STI Wire Guards



STI-9601



STI-9602



STI-9605



STI-9604



STI-9609



STI-9610



STI-9713



These UL Listed guards are for areas where abuse to smoke detectors is severe. To create them, STI borrowed from nature's master builder, the spider, to create a web of protection from vandalism and accidental damage. Constructed of 9-gauge steel wire, with corrosion resistant polyester coating, these Stoppers are extremely difficult to break. Installation and service are easy with models for both flush and surface

mounting. Many models are available to fit virtually all smoke detectors. Models available for smoke detectors without conduits are the STI-9604 for smaller size units, the STI-9601 for low-profile detectors and the STI-9609 for high-profile units. Allowing for conduit spacing are the STI-9605 (for smaller size detectors), STI-9602 (low profile) and STI-9610 (high profile). The STI-9713 is for use with photoelectric smoke detectors.

FEATURES

- Patented weblike octagon shape of 9-gauge coated steel wire makes them extremely difficult to break.
- Fast, easy installation.
- Tamper resistant hardware is available.
- Many models to fit virtually all smoke detectors available today.
- Simple removal for servicing detector.
- May be spray painted once prior to installation to match decor.
- UL and cUL Listed (No. S3504) and CSFM (7300-1416:100) approved.
- STI-9713 UL Listed (No. S3504) for specific detectors (see spec sheet for details).
- Three year guarantee against breakage in normal use.

Dimensions and Technical Information

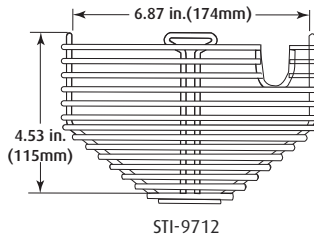
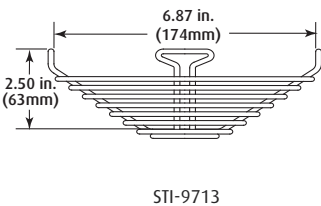
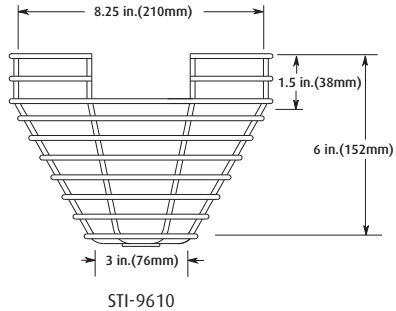
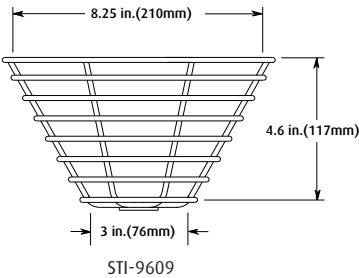
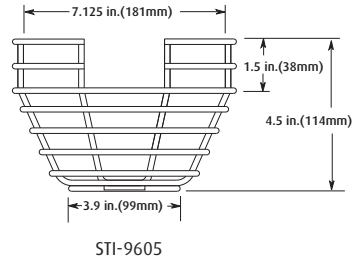
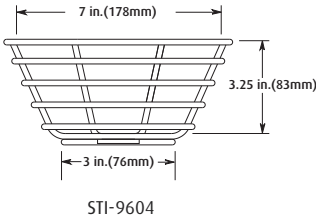
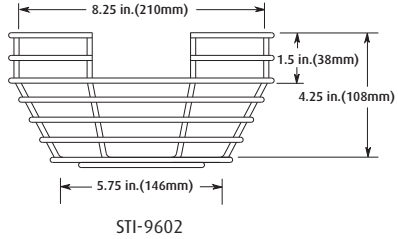
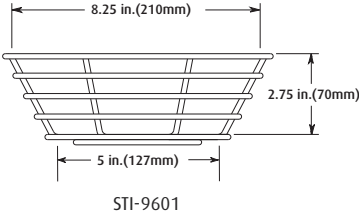

NOTE: All models are UL Listed except STI-9712.

Steel Web Stoppers



STI-9604-SS



STI-9609-SS



STI-9605-SS



As their polyester coated cousins, these Stoppers feature 9-gauge stainless steel wire construction in a weblike design that creates protection against abuse to

smoke detectors. Many sizes available for flush and surface mounting.

See page 3 for product dimensions.

FEATURES

- Patented weblike octagon shape of 9-gauge steel wire makes them extremely difficult to break.
- Tamper resistant hardware is available.
- Many models to fit virtually all smoke detectors available today.
- Simple removal for servicing detector.
- May be spray painted once prior to installation to match decor.
- UL and cUL Listed (No. S3504) and CSFM (7300-1416:100) approved.
- Three year guarantee against breakage in normal use.
- Fast, easy installation.

Smoke Beam Guards



STI-9706



STI-9623



STI-9624



STI-9840



STI-9841



STI-9625

Protect projected beam type smoke detectors in large areas such as gymnasiums, warehouses and auditoriums. STI-9623 is used on Detection Systems 240 and DS 241 long-range projected beam smoke detectors.

STI-9625 designed for use on the 6424 System Sensor Infrared Beam Smoke Detector. STI-9624 designed to protect Fireray 50/100R. STI-9706 (flush mount) and STI-9707 (surface mount) are used on System Sensor 1224.

PART #	HEIGHT	WIDTH	DEPTH
STI-9623	7.75 in. (196 mm)	6 in. (152 mm)	6 in. (152 mm)
STI-9624	8.875 in. (225 mm)	5.5 in. (140 mm)	4.75 in. (120 mm)
STI-9625	7.875 in. (200 mm)	10.25 in. (260 mm)	12.625 in. (321 mm)
STI-9706	10.82 in. (275 mm)	9.32 in. (237 mm)	4 in. (120 mm)
STI-9707	11 in. (280 mm)	9.62 in. (244 mm)	5.5 in. (140 mm)
STI-9840	6.61 in. (168 mm)	6.61 in. (168 mm)	5.78 in. (147 mm)
STI-9841	11.52 in. (293 mm)	10 in. (256 mm)	3.58 in. (91 mm)

FEATURES

- Tough construction of 9-gauge coated steel wire makes STI Smoke Beam Guards extremely difficult to break.
- Coated with a tough, corrosion resistant polyester shell.
- Protection against misalignment and false alarms.
- Designed to protect both transmitter and receiver units.
- Three year guarantee against breakage in normal use.

Smoke Detector Damage Stopper®



STI-8230-SS



STI-8200-W



certain smoke detectors only

Stainless Steel

This heavy-duty, 1.2 mm stainless steel cover features a natural resistance to corrosion. This makes it an excellent choice for any application where food is present as well as use in water treatment plants and correctional facilities. It is available for flush mount (STI-8200-SS) or with a conduit spacer for surface mount (STI-8230-SS, shown). Easy to install, it helps assure the smoke detector will remain operational in applications where vandalism and accidental damage are causing false fire alarms or high maintenance costs.

Coated Cold Rolled Steel

Here is a protective cover for persons who prefer the strength and durability of steel but need not be concerned with the presence of food in the area. It is fabricated from 1.5 mm cold rolled steel with a white corrosion resistant polyester coating. As the stainless steel cover, it is available for flush mount (STI-8200-W, shown) or with a spacer for surface mount (STI-8230-W). Tamper resistant hardware is available for all models if added protection against vandalism is a concern.

Stainless Steel (1.2 mm)

STI-8200-SS	Smoke detector cover - flush mount
STI-8201-SS	Spacer for conduit applications
STI-8230-SS	Cover and Spacer - surface mount

Cold Rolled Steel coated white (1.5 mm)

STI-8200-W	Smoke detector cover - flush mount
STI-8201-W	Spacer for conduit applications
STI-8230-W	Cover and Spacer - surface mount
SUB-82	Tamperproof screws for flush mounted covers
19038	Snake eye bit for use with SUB-82
STI-8170	Mounting backplate for flush and surface mount models. Recommended for irregular and unstable mounting surfaces such as drop ceilings and beams.

FEATURES

- Cover is UL and cUL Listed for System Sensor SSD-2251, FCI ASD-PL, Secutron MRI-2251, EST 2251F and Honeywell TC806B1001 for ceiling and wall mount applications.
- Aesthetically pleasing stainless steel or coated cold rolled steel.
- They help assure smoke detectors will be operational when needed.
- Exceptional durability.
- Covers protect against severe vandalism and accidental damage.
- Available conduit spacers allow them to be easily mounted over surface mount applications with or without conduit.
- Easy installation and easy removal for servicing detectors.
- Tamper resistant hardware is available for all models.

Smoke Detector Damage Stopper®

Dimensions and Technical Information

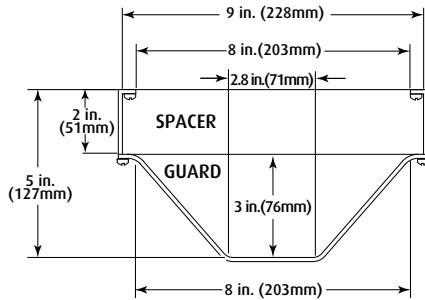
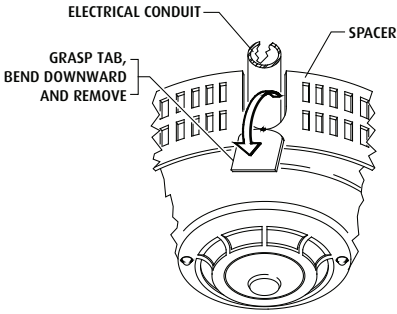

PRODUCT DIMENSIONS

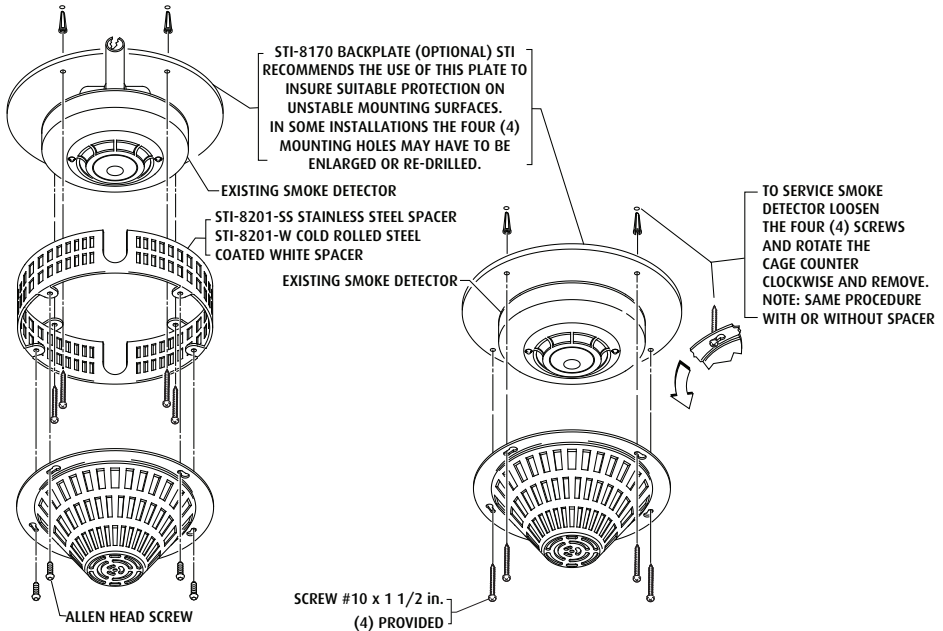

SURFACE MOUNT INSTALLATION

FLUSH MOUNT INSTALLATION

Speaker/Strobe Damage Stopper® and Horn/Strobe/Speaker Damage Stopper®

STI Wire Guards

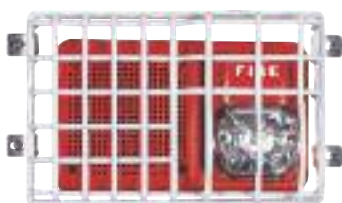

STI-9717



STI-9720

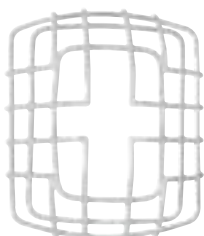

STI-9705



STI-9708-R



STI-9714



MODEL	HEIGHT	WIDTH	DEPTH
STI-9705	7.40 in. (188mm)	6.15 in. (156mm)	3.39 in. (84mm)
STI-9705-R	7.40 in. (188mm)	6.15 in. (156mm)	3.39 in. (84mm)
STI-9708	7.49 in. (190mm)	6.74 in. (171mm)	6.09 in. (155mm)
STI-9708-R	7.49 in. (190mm)	6.74 in. (171mm)	6.09 in. (155mm)
STI-9711	8.26 in. (210mm)	8.26 in. (210mm)	3.54 in. (90mm)
STI-9714	8.55 in. (217mm)	8.55 in. (217mm)	6.23 in. (158mm)
STI-9717	6.1 in. (155mm)	9.3 in. (238mm)	2.4 in. (61mm)
STI-9720	6.1 in. (155mm)	9.3 in. (238mm)	4.9 in. (125mm)

These tough wire guards are designed to protect appliances against vandalism and accidental damage. They consist of tough, 9-gauge steel wire coated with corrosion resistant white or red polyester,

which offers excellent security. Weblike shape helps unit take tough knocks in stride. Tamper resistant hardware and bit available.

FEATURES

- Helps prevent accidental or intentional damage and vandalism.
- Weblike shape of 9-gauge steel wire makes them extremely difficult to break.
- STI-9717 and STI-9720 (not UL Listed) designed to fit over System Sensor notification appliances SP2R1224MC and SP2W1224MC.
- STI-9705, STI-9708, STI-9711 and STI-9714 are UL/cUL Listed.
- Simple removal for servicing or routine maintenance.
- Three year guarantee against breakage in normal use.



STI-9618



STI-9619



STI-9620



STI-9621



STI-9622

STI customers asked for them, tough guards to protect PIR, microwave or dual technology motion detectors. These Stoppers do the job. They are extremely effective in reducing malfunctions and high maintenance costs where vandalism

or accidental damage is prevalent. Plus, they do not interfere with effective range of detectors. Sizes to fit virtually all motion detectors, including two for corner mount applications. Tamper resistant hardware is available.

PART #	HEIGHT	WIDTH	DEPTH
STI-9618	4.62 in.(117 mm)	5.37 in.(136 mm)	3 in.(76 mm)
STI-9619	7.75 in.(196mm)	5.37 in.(136mm)	5.62 in.(142mm)
STI-9620	6.25 in.(159 mm)	4 in.(102 mm)	2.25 in.(57 mm)
STI-9621	7 in.(178 mm)	5.75 in.(146 mm)	4.5 in.(114 mm)
STI-9622	8.75 in.(222 mm)	4 in.(102 mm)	3.75 in.(95 mm)

FEATURES

- Construction of 9-gauge, welded steel wire.
- Coated with a tough, corrosion resistant polyester shell.
- Protection against both vandalism and accidental damage.
- Designed so there is no interference with the operation or usefulness of the protected unit.
- Three year guarantee against breakage in normal use.

Exit Sign Damage Stopper®

STI Wire Guards

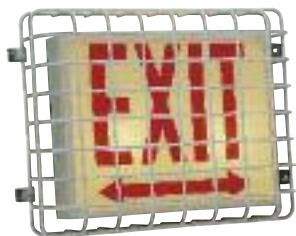

STI-9640



STI-9740

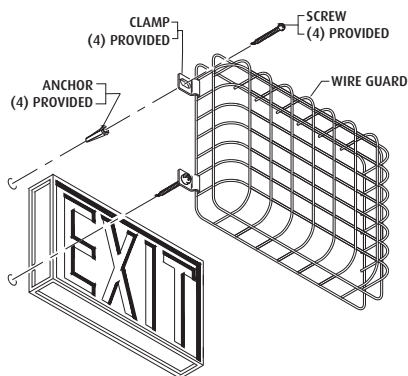

Wherever exit signs are at risk from either intentional or accidental damage, installation of these tough wire guards is the solution to the problem. These guards cover a wide range of exit sign models

available today. Installation is simple with anchors and screws provided. Tamper resistant screws (SUB-82) and a matching bit (19038) are available.

FEATURES

- Tough construction of 9-gauge polyester coated steel wire makes it extremely difficult to break.
- Large enough to cover a wide range of exit signs.
- Simple removal for light bulb replacement.
- Tamper resistant hardware is available.
- May be painted prior to installation to match decor.
- Fast, easy installation.
- STI-9640 measures 13.75 in. wide x 10.5 in. high x 2.75 in. deep (349mm x 267mm x 70mm).
- STI-9740 measures 20.5 in. wide x 15.5 in. high x 6 in. deep (520mm x 394mm x 152mm).
- Guard may reduce projected light values. Verify correct exit light requirements when using guard (NFPA 101).
- Three year guarantee against breakage in normal use.

Clock/Bell Damage Stopper®



STI-9632

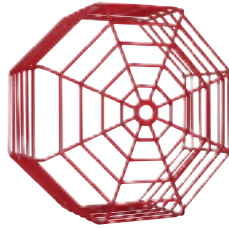

STI-9631-R

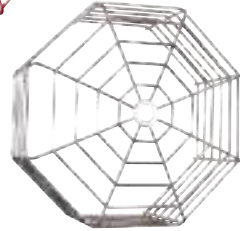

STI-9631-SS

These tough covers are designed to protect clocks, bells and similar instruments. Their octagon shape also helps them take tough knocks in stride. They are ideal for areas where abuse is severe. Because they are white in color, users report that their clock numbers

are easier to see than with darker competitive guards. Guards are also available in red for large volume orders. Multiple sizes and tamper resistant hardware are available. STI-9631-R and STI-9631-SS are available for larger quantity orders only.

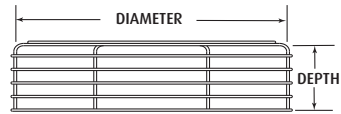
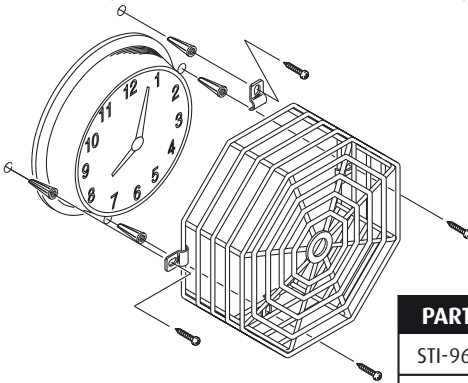

PART #	DIAMETER	DEPTH
STI-9631	10.5 in.(267mm)	6 in.(152mm)
STI-9632	16.5 in.(419mm)	6 in.(152mm)
STI-9633	20 in.(508mm)	6 in.(152mm)

FEATURES

- Weblike octagon shape of 9-gauge coated steel wire makes them extremely difficult to break.
- Fast, easy installation.
- Simple removal for servicing or routine maintenance.
- Tamper resistant hardware is available.
- Many models to fit a wide range of

- units.
- May be painted prior to installation to match decor.
- Three year guarantee against breakage in normal use.

Bay Light Damage Stopper®

STI Wire Guards



STI-9702



STI-9709

Special order. Contact customer service for lead times.

These tough, 9-gauge polyester coated steel wire guards help protect Hubbell® Superbay lights against both vandalism and accidental damage. They are easy to install with all fasteners provided. Guard bolts directly to the transformer

(not the reflective lens like most other guards) providing more strength to protect the expensive reflector. Light bulb replacement is easy without the removal of the guard.

FEATURES

- Offers protection against vandalism and accidental damage for warehouse or sport facility lights.
- Constructed of tough 9-gauge steel wire.
- Installation is fast and simple with screws and nuts provided.
- Fits reflector mounting kit in all positions.
- STI-9702 fits 3 Hubbell models: WA-22, WD-22 and BL-WA22.
- STI-9709 fits existing Hubbell WA25 series.
- Three year guarantee against breakage in normal use.

Light Damage Stopper® and Emergency Light Damage Stopper®



STI-9649



STI-9703

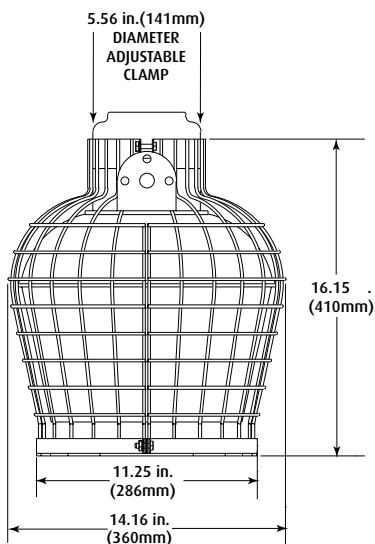

STI-9796

MODEL	HEIGHT	WIDTH	DEPTH
STI-9641	10.7 (271mm)	14.6 (370mm)	4 (101mm)
STI-9644	8.7 (220mm)	17.75 (450mm)	5.25 (133mm)
STI-9645	13.75 (349mm)	21.6 (548mm)	5.9 (149mm)
STI-9649	10.75 (273mm)	24.75 (629mm)	11.25 (286mm)
STI-9703	5.0 (127mm)	13.5 (343mm)	4 (101mm)
STI-9730	12 (305mm)	12 (305mm)	12 (305mm)

These Stoppers help protect important security devices from theft and vandalism. They are constructed of tough 9-gauge steel wire coated with corrosion

resistant polyester. Highly recommended for areas where abuse is severe or it is imperative security devices continue to operate.

FEATURES

- Offers protection against vandalism and accidental damage for important security devices.
- Installation is fast and simple with screws and anchors provided.
- Constructed of tough 9-gauge steel wire coated with corrosion resistant polyester.
- Three year guarantee against breakage in normal use.

Fluorescent Light Damage Stoppers®

STI Wire Guards



STI-9651

Special order. Contact customer service for lead times.

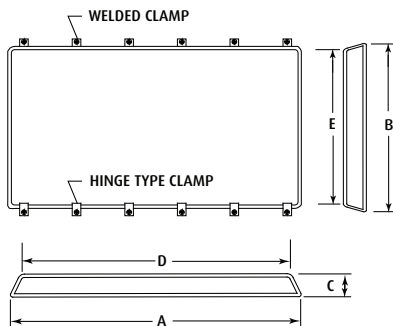

STI-9880 and STI-9881

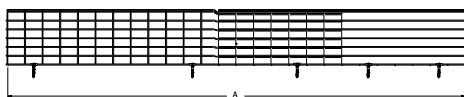
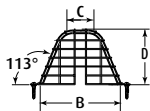

	A*	B	C	D
STI-9651	53.50 in. (1359mm)	29.50 in.(750mm)	50 in.(1270mm)	4 in.(102mm)
STI-9880	59 in. (1500mm)	9.5 in.(242mm)	4 in.(110mm)	6 in.(152mm)
STI-9881	94 in. (2400mm)			

* **STI-9880** Adjustable length reduces to 47.25 in.(1200mm)

STI-9881 Adjustable length reduces to 70.87 in.(1800mm)

Here is a way to help assure large fluorescent lights continue to illuminate important areas and to avoid frequent replacement of bulbs because of vandalism, accidental damage or other abuse. They are easy to install with all

screws and anchors provided. Constructed of tough wire coated with corrosion resistant polyester. To help accommodate various fluorescent twin-tube lighting fixtures, the STI-9880 and STI-9881 are adjustable in length.

FEATURES

- Constructed of corrosion resistant, polyester coated steel wire.
- Helps assure continued illumination of key areas.
- The STI-9880 and STI-9881 are adjustable in length to help accommodate various fluorescent twin-tube lighting fixtures.
- Protects against vandalism and accidental damage.
- Easy to install and easy removal for service.
- Three year guarantee against breakage in normal use.

Custom Wire Guards

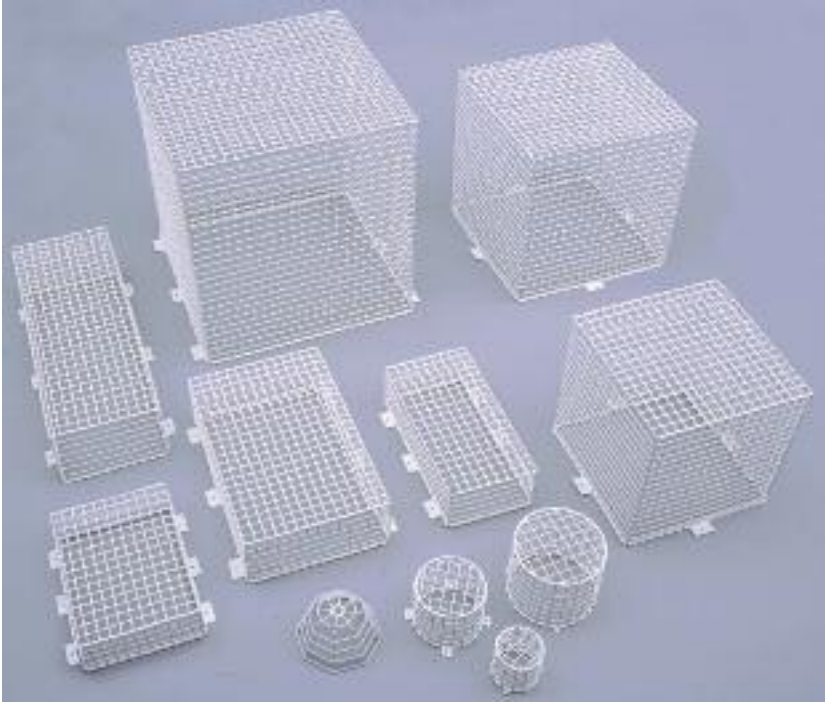

Custom wire guards in white, red or stainless steel are available for larger quantity orders. Please call for details. As all STI wire guards, they are backed by a three year guarantee against breakage in normal use.

Additional wire guards are available from our UK office. Constructed of tough, corrosion resistant, coated wire. These

web guards are designed to take tough knocks in stride. Designed for emergency lights, beacon sounders, smoke detectors, CCTVs, external lighting and exit lights. Guards range in size from approximately 3.64 in. dia. x 3.54 in. deep (95mm x 90mm) to approximately 25 in. square (635mm). There is a six week lead time required on most custom wire guards.

FEATURES

- Offers protection against vandalism and accidental damage.
- Constructed of tough steel wire.
- Coated with corrosion resistant polyester.
- Three year guarantee against breakage in normal use.
- Tough construction makes these guards extremely difficult to break.
- Fast and easy to install.

Call us for additional literature
or visit us at:

www.sti-usa.com/w13
800-888-4784



"We Protect the Things that Protect You."

Safety Technology International, Inc.

2306 Airport Road, Waterford, Michigan 48327

Phone: 248-673-9898 Fax: 248-673-1246

Email: info@sti-usa.com Web: www.sti-usa.com

Safety Technology International, (Europe) Ltd.

Unit 49G Pipers Road • Park Farm Industrial Estate • Redditch
Worcestershire • B98 0HU • England • Tel: 44 (0) 1527 520 999
Fax: 44 (0) 1527 501 999 • Freephone: 0800 085 1678 (UK only)
E-mail: info@sti-europe.com • Web: www.sti-europe.com