

# Operating Instructions

## Series 30000 Electric Motor Driven Reels

EA30106 L10A	EA32118 L12D	EA33112 L10A	EA33122 L12D
EA30112 L12D	EA32118 M12D	EA33112 L12D	EA33128 L12D
EA32106 L10A	EA32118 M24D	EA33112 M10AX	EA33128 M12D
EA32106 L12D	EA32122 L12D	EA33112 M12D	
EA32106 M10A	EA32122 M12D	EA33112 M24D	
EA32106 M12D	EA32128 L12D	EA33118 L10A	
EA32112 L10A	EA32128 M12D	EA33118 L12D	
EA32112 L12D	EA33106 L12D	EA33118 M10AX	
EA32112 M12D	EA33106 M12D	EA33118 M12D	



### Dimensional Data

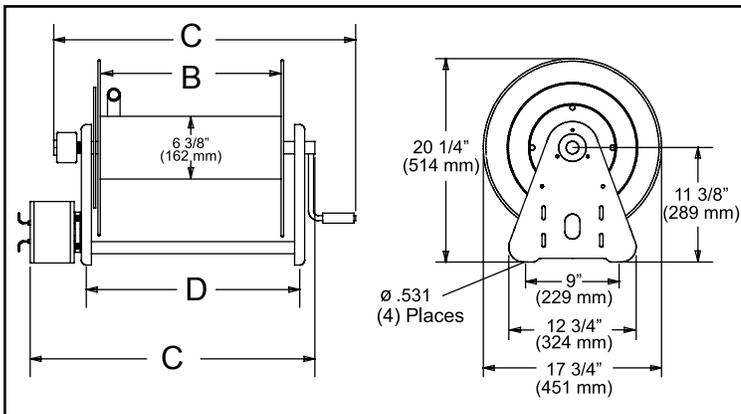

Part #	B	C	D	Part #	B	C	D
EA30106 L10A	6"	19 5/8"	9 3/4"	EA32128 M12D	27"	38 5/8"	30 3/4"
EA30112 L12D	12"	25 5/8"	15 3/4"	EA33106 L12D	6"	19 5/8"	9 3/4"
EA32106 L10A	6"	19 5/8"	9 3/4"	EA33106 M12D	6"	19 5/8"	9 3/4"
EA32106 L12D	6"	19 5/8"	9 3/4"	EA33112 L10A	12"	25 5/8"	15 3/4"
EA32106 M10A	6"	19 5/8"	9 3/4"	EA33112 L12D	12"	25 5/8"	15 3/4"
EA32106 M12D	6"	19 5/8"	9 3/4"	EA33112 M10AX	12"	25 5/8"	15 3/4"
EA32112 L10A	12"	25 5/8"	15 3/4"	EA33112 M12D	12"	25 5/8"	15 3/4"
EA32112 L12D	12"	25 5/8"	15 3/4"	EA33112 M24D	12"	25 5/8"	15 3/4"
EA32112 M12D	12"	25 5/8"	15 3/4"	EA33118 L10A	18"	29 5/8"	21 3/4"
EA32118 L12D	18"	29 5/8"	21 3/4"	EA33118 L12D	18"	29 5/8"	21 3/4"
EA32118 M12D	18"	29 5/8"	21 3/4"	EA33118 M10AX	18"	29 5/8"	21 3/4"
EA32118 M24D	18"	29 5/8"	21 3/4"	EA33118 M12D	18"	29 5/8"	21 3/4"
EA32122 L12D	22"	33 5/8"	25 3/4"	EA33122 L12D	22"	33 5/8"	25 3/4"
EA32122 M12D	22"	33 5/8"	25 3/4"	EA33128 L12D	27"	38 5/8"	30 3/4"
EA32128 L12D	27"	38 5/8"	30 3/4"	EA33128 M12D	27"	38 5/8"	30 3/4"

### Safety Precautions

Personal injury and/or equipment damage may result if proper safety precautions are not observed.

- Ensure that the reel has been properly installed before connecting supply line (see installation instructions).
- Bleed fluid/gas pressure from system before servicing reel.
- Before connecting reel to supply line ensure that supply line pressure does not exceed maximum rated working pressure of reel.
- Do not play pranks on other personnel. Even low pressure is very dangerous and can cause irreparable damage or death.
- Do not wear loose fitting clothing while operating reel.
- Be aware of other personnel in work area.
- Be aware of other machinery in work area.
- If a leak occurs in the hose or reel, remove supply line pressure immediately.
- If the reel is power driven check for loose, frayed, and/or broken wires before operating.
- Treat and respect a hose reel as any other piece of machinery, observing all common safety practices.

Form# 837-696B Rev: 8/2014

## INSTALLATION INSTRUCTIONS

### Inspection

Unpack and inspect the reel for damage. Turn the reel by hand to check for smooth operation. Check for completeness.

### Mounting of all hose reels

**NOTE:** Ensure that mounting surface is flat to prevent binding on reel after it is mounted.

- Two 1/2" diameter mounting holes are located at the base of each side support panel (2 each). Mount reel using four (customer supplied) bolts; tightening them securely to ensure a solid, rigid attachment.

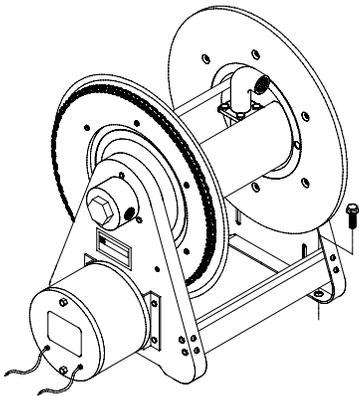

- Perform the following steps only after all other installation steps, pertaining to your particular reel, are accomplished. Refer to page 4 for special instructions.

**NOTE:** A flexible hose connection must be used to compensate for any offset between the supply line and the reel swivel.

- Apply thread compound to all threads.
- Thread male connector of supply line into swivel. Tighten securely.

**CAUTION:** Remove all electrical power when wiring. Do not "hot-wire". Observe all applicable NEC/OSHA requirements.

- Ensure that supply and motor voltage ratings are compatible.
- Consult wiring diagrams and determine which one is applicable to your reel.
- Perform electrical wiring following applicable diagram.

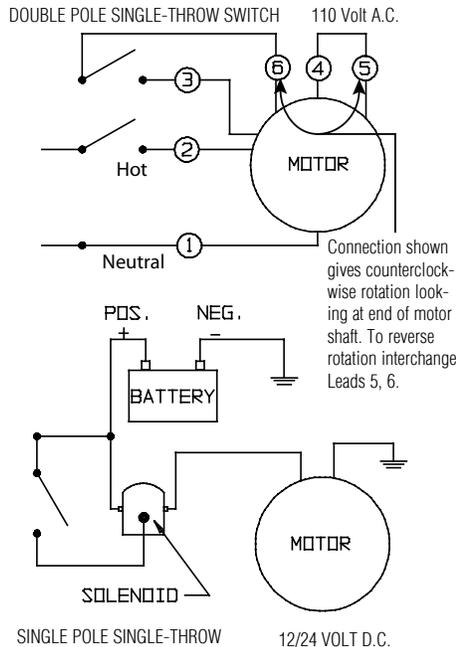

### Connecting the hose

**CAUTION:** Do not connect the hose to the connecting tube assembly until after hose reel has been installed. Fully extend and charge hose before winding on or reel. Momentarily open control valve, when initially charging, to purge hose of gases. When fluid appears at control valve, close valve. This prevents flattening of the hose and excessive pressure on the drum when fluid supply is reinitialized at a later time.

- Apply thread compound to all threads.
- Hand thread male hose connector into connecting tube assembly.
- Using a wrench, firmly hold onto connecting tube assembly while tightening hose connector.

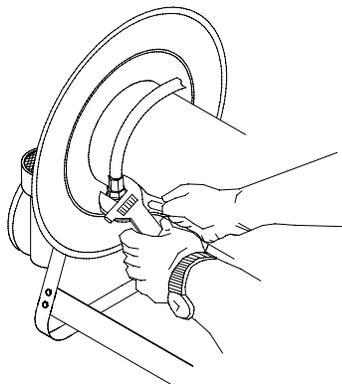

## OPERATING INSTRUCTIONS

### WARNING-PREVENT STATIC

**SPARKING:** When working around flammable liquids such as solvents, paints, chemicals or petroleum products, ensure that the hose reel, hose and the equipment being serviced are properly grounded. Use grounded hose(s) (static wire). Use an ohmmeter to check continuity of the ground circuit. Fire and/or explosion can result if proper grounding is not achieved. If reel is power or air driven, be careful of chain/sprocket drive system. Keep hands clear. Do not wear loose fitting clothing. Pull hose from the reel by grasping the hose itself, not the control handle or swivel.

## SERVICE INSTRUCTIONS

### Replacing the hose

- Using a wrench, firmly hold onto the connecting tube assembly while removing hose connector.
- Follow procedures for "Connecting the hose" (refer to installation instructions).

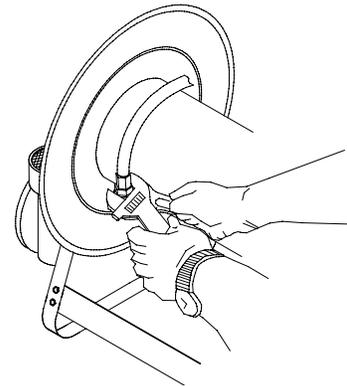

### Replacing the swivel

**CAUTION:** Remove supply line pressure before performing the following procedure.

- Remove supply line from swivel.
- Remove swivel assembly from inlet shaft.
- Install swivel assembly to inlet shaft by reversing steps 1 and 2. Apply thread compound to all threads.

### Replacing the motor

**CAUTION:** Before replacing the motor, remove all electrical power from motor.

1. Disconnect wiring lines from motor.
2. Remove bolts securing motor mounting bracket to reel. Remove bracket (refer to diagram on page 3).
3. Install swivel assembly to inlet shaft by reversing steps 1 and 2. Apply thread compound to all threads.

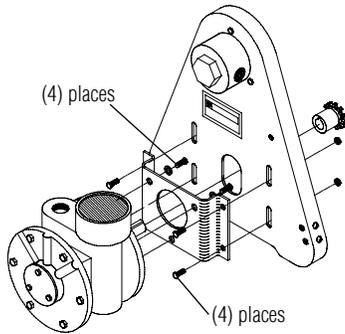

### Replacing the chain

**CAUTION:** Before replacing the chain, remove all electrical power from motor.

1. Loosen (do not remove) bolts securing motor mounting bracket in place.
2. Remove chain master-link.
3. Remove chain master-link. Install new chain by reversing steps 1 and 2 above.

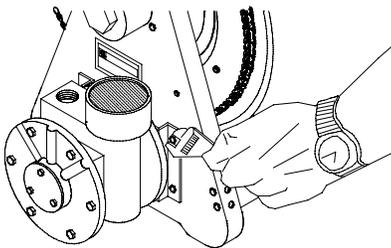

## ADJUSTMENT PROCEDURES

### Adjusting the reel

1. Adjust reel drag by loosening or tightening set screw on hub casting on manual driven reel.

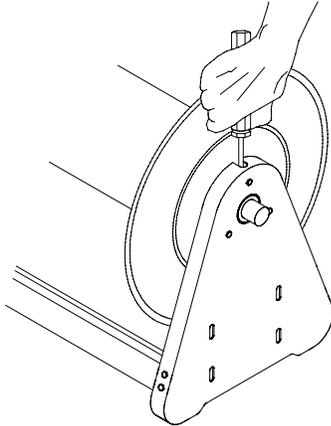

### Adjusting the chain tension

**CAUTION:** Before adjusting the chain tension, remove all electrical power from motor. Over-tensioned (tightening) of chain results in reduced motor life. Adjust to allow between 1/4 and 1/2 inch play in chain.

1. Loosen bolts (do not remove) securing motor mounting bracket to reel.
2. Move motor mounting bracket and motor until proper chain tension is obtained.
3. Tighten motor mounting bracket bolts.

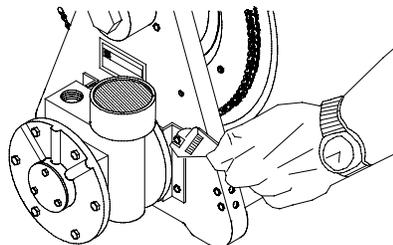

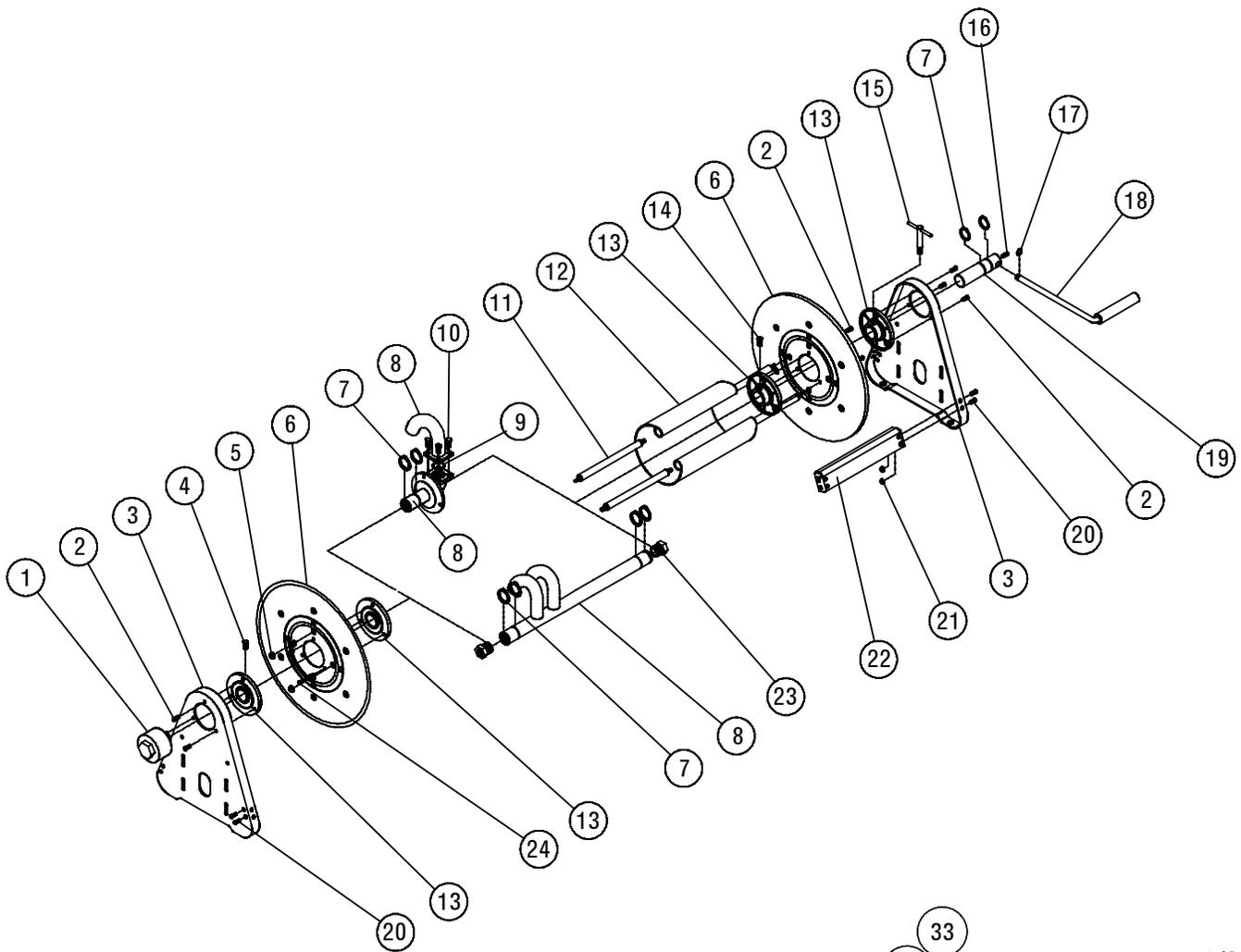

1/2 H.P.  
Explosion  
Proof Motor

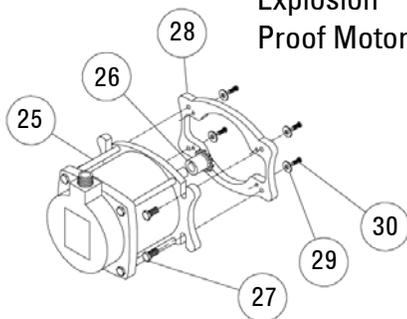

1/3 H.P.  
Motor

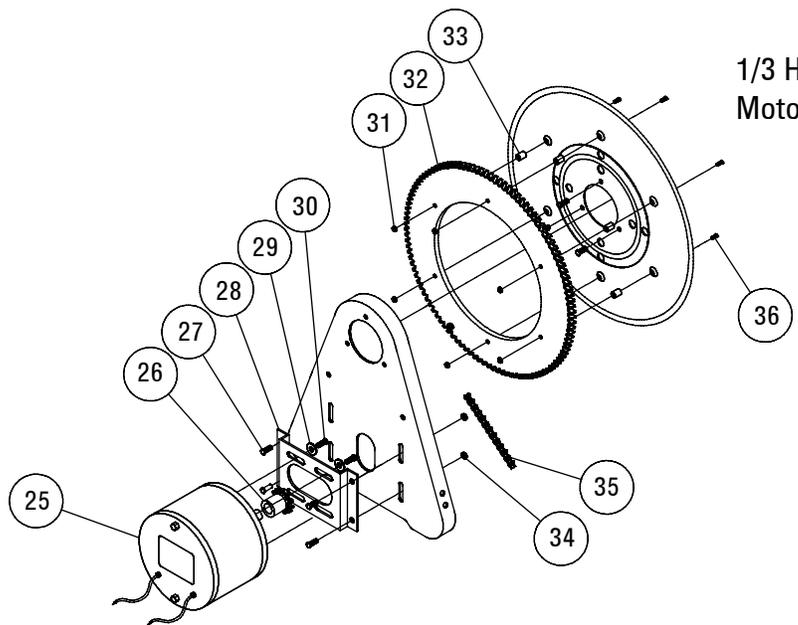

Series 30000 Electric Motor Driven Reels

ITEM	DESCRIPTION	QTY.	EA30106 L10A	EA30112 L12D	EA32106 L10A	EA32106 L12D	EA32106 M10A	EA32106 M12D	EA32112 L10A	EA32112 L12D
1	Swivel assembly	1	None	None	600888	600888	S602033	S602033	600888	600888
2	Screw, 5/16-12 x 5/8"	9	S317-31	S317-31	S317-31	S317-31	S317-31	S317-31	S317-31	S317-31
3	Side frame	2	260403	260403	260403	260403	260403	260403	260403	260403
5	Nut, 5/16-18	8	S85-7	S85-7	S85-7	S85-7	S85-7	S85-7	S85-7	S85-7
6	Spool flange	2	S260399-3	S260399-3	S260399-3	S260399-3	S260399-3	S260399-3	S260399-3	S260399-3
7	Snap ring	4	300007	300007	300007	300007	300007	300007	300007	300007
8	Inlet assembly	1	600327-2	600327-2	600327-1	600327-1	600327-1	600327-1	600327-1	600327-1
9	O-ring	1	S211-120	S211-120	S211-120	S211-120	S211-120	S211-120	S211-120	S211-120
10	Screw, 5/16-18 x 3/4"	4	S7-51	S7-51	S7-51	S7-51	S7-51	S7-51	S7-51	S7-51
11	Tie rod	4	260402-100	260402-200	260402-100	260402-100	260402-100	260402-100	260402-200	260402-200
12	Spacer	4	260401-1	260401-2	260401-1	260401-1	260401-1	260401-1	260401-2	260401-2
13	Hub & bushing assembly	3	S600640	S600640	S600640	S600640	S600640	S600640	S600640	S600640
15	Lock handle assembly	1	S280109	S280109	S280109	S280109	S280109	S280109	S280109	S280109
20	Screw, 5/16-18 x 1/2"	8	S2-51	S2-51	S2-51	S2-51	S2-51	S2-51	S2-51	S2-51
21	Nut, 5/16-18	8	300107	300107	300107	300107	300107	300107	300107	300107
22	Cross brace	2	261501-1	261501-2	261501-1	261501-1	261501-1	261501-1	261501-2	261501-2
24	Screw, 1/4-20 x 5/8"	3	S2-42	S2-42	S2-42	S2-42	S2-42	S2-42	S2-42	S2-42
25	Drive motor	1	S260430	S260409	S260430	S260409	S260430	S260409	S260430	S260409
26	Gear, motor	1	260434	S260408	260434	S260408	260434	S260408	260434	S260408
27	Screw 5/16-18 x 5/8"	4	S2-52	S2-52	S2-52	S2-52	S2-52	S2-52	S2-52	S2-52
28	Bracket, motor	1	260456	260405	260456	260405	260456	260405	260456	260405
29	Washer	4	300039	300039	300039	300039	300039	300039	300039	300039
30	Screw 5/16-18 x 5/8"	4	S2-52	S2-52	S2-52	S2-52	S2-52	S2-52	S2-52	S2-52
31	Flange nut 10-32	6	S79-3	S79-3	S79-3	S79-3	S79-3	S79-3	S79-3	S79-3
32	Spool gear	1	260407	260407	260407	260407	260407	260407	260407	260407
33	Spacer, gear	6	S260410	S260410	S260410	S260410	S260410	S260410	S260410	S260410
34	Lock nut 5/16-18	4	S85-7	S85-7	S85-7	S85-7	S85-7	S85-7	S85-7	S85-7
35	Chain, drive #35	1	S260406	S260406	S260406	S260406	S260406	S260406	S260406	S260406
36	Screw 10-31 x 1 1/8"	6	S27-112	S27-112	S27-112	S27-112	S27-112	S27-112	S27-112	S27-112

ITEM	DESCRIPTION	QTY.	EA32112 M12D	EA32118 L12D	EA32118 M12D	EA32118 M24D	EA32122 L12D	EA32122 M12D	EA32128 L12D	EA32128 M12D
1	Swivel assembly	1	S602033	600888	S602033	S602033	600888	S602033	600888	S602033
2	Screw, 5/16-12 x 5/8"	9	S317-31	S317-31	S317-31	S317-31	S317-31	S317-31	S317-31	S317-31
3	Side frame	2	260403	260403	260403	260403	260403	260403	260403	260403
5	Nut, 5/16-18	8	S85-7	S85-7	S85-7	S85-7	S85-7	S85-7	S85-7	S85-7
6	Spool flange	2	S260399-3	S260399-3	S260399-3	S260399-3	S260399-3	S260399-3	S260399-3	S260399-3
7	Snap ring	4	300007	300007	300007	300007	300007	300007	300007	300007
8	Inlet assembly	1	600327-1	600327-1	600327-1	600327-1	600327-1	600327-1	600327-1	600327-1
9	O-ring	1	S211-120	S211-120	S211-120	S211-120	S211-120	S211-120	S211-120	S211-120
10	Screw, 5/16-18 x 3/4"	4	S7-51	S7-51	S7-51	S7-51	S7-51	S7-51	S7-51	S7-51
11	Tie rod	4	260402-200	260402-300	260402-300	260402-300	260402-400	260402-400	260402-500	260402-500
12	Spacer	4	260401-2	S260401-3	S260401-3	S260401-3	260401-4	260401-4	260401-5	260401-5
13	Hub & bushing assembly	3	S600640	S600640	S600640	S600640	S600640	S600640	S600640	S600640
15	Lock handle assembly	1	S280109	S280109	S280109	S280109	S280109	S280109	S280109	S280109
20	Screw, 5/16-18 x 1/2"	8	S2-51	S2-51	S2-51	S2-51	S2-51	S2-51	S2-51	S2-51
21	Nut, 5/16-18	8	300107	300107	300107	300107	300107	300107	300107	300107
22	Cross brace	2	261501-2	261501-3	261501-3	261501-3	261501-4	261501-4	261501-5	261501-5
24	Screw, 1/4-20 x 5/8"	3	S2-42	S2-42	S2-42	S2-42	S2-42	S2-42	S2-42	S2-42
25	Drive motor	1	S260409	S260409	S260409	260450	S260409	S260409	S260409	S260409
26	Gear, motor	1	S260408	S260408	S260408	S260408	S260408	S260408	S260408	S260408
27	Screw 5/16-18 x 5/8"	4	S2-52	S2-52	S2-52	S2-52	S2-52	S2-52	S2-52	S2-52
28	Bracket, motor	1	260405	260405	260405	260405	260405	260405	260405	260405
29	Washer	4	300039	300039	300039	300039	300039	300039	300039	300039
30	Screw 5/16-18 x 5/8"	4	S2-52	S2-52	S2-52	S2-52	S2-52	S2-52	S2-52	S2-52
31	Flange nut 10-32	6	S79-3	S79-3	S79-3	S79-3	S79-3	S79-3	S79-3	S79-3
32	Spool gear	1	260407	260407	260407	260407	260407	260407	260407	260407
33	Spacer, gear	6	S260410	S260410	S260410	S260410	S260410	S260410	S260410	S260410
34	Lock nut 5/16-18	4	S85-7	S85-7	S85-7	S85-7	S85-7	S85-7	S85-7	S85-7
35	Chain, drive #35	1	S260406	S260406	S260406	S260406	S260406	S260406	S260406	S260406
36	Screw 10-31 x 1 1/8"	6	S27-112	S27-112	S27-112	S27-112	S27-112	S27-112	S27-112	S27-112

Series 30000 Electric Motor Driven Reels

ITEM	DESCRIPTION	QTY.	EA33106 L12D	EA33106 M12D	EA33112 L10A	EA33112 L12D	EA33112 M10AX	EA33112 M12D	EA33112 M24D
1	Swivel assembly	1	S602026	S602026	S602026	S602026	S602026	S602026	S602026
2	Screw, 5/16-12 x 5/8"	9	S317-31	S317-31	S317-31	S317-31	S317-31	S317-31	S317-31
3	Side frame	2	260403	260403	260403	260403	260403	260403	260403
5	Nut, 5/16-18	8	S85-7	S85-7	S85-7	S85-7	S85-7	S85-7	S85-7
6	Spool flange	2	S260399-3	S260399-3	S260399-3	S260399-3	S260399-3	S260399-3	S260399-3
7	Snap ring	4	300007	300007	300007	300007	300007	300007	300007
8	Inlet assembly	1	600327-2	600327-2	600327-2	600327-2	600327-2	600327-2	600327-2
9	O-ring	1	S211-120	S211-120	S211-120	S211-120	S211-120	S211-120	S211-120
10	Screw, 5/16-18 x 3/4"	4	S7-51	S7-51	S7-51	S7-51	S7-51	S7-51	S7-51
11	Tie rod	4	260402-100	260402-100	260402-200	260402-200	260402-200	260402-200	260402-200
12	Spacer	4	260401-1	260401-1	260401-2	260401-2	260401-2	260401-2	260401-2
13	Hub & bushing assembly	3	S600640	S600640	S600640	S600640	S600640	S600640	S600640
15	Lock handle assembly	1	S280109	S280109	S280109	S280109	S280109	S280109	S280109
20	Screw, 5/16-18 x 1/2"	8	S2-51	S2-51	S2-51	S2-51	S2-51	S2-51	S2-51
21	Nut, 5/16-18	8	300107	300107	300107	300107	300107	300107	300107
22	Cross brace	2	261501-1	261501-1	261501-2	261501-2	261501-2	261501-2	261501-2
24	Screw, 1/4-20 x 5/8"	3	S2-42	S2-42	S2-42	S2-42	S2-42	S2-42	S2-42
25	Drive motor	1	S260409	S260409	S260430	S260409	S260430	S260409	260450
26	Gear, motor	1	S260408	S260408	260434	S260408	260434	S260408	S260408
27	Screw 5/16-18 x 5/8"	4	S2-52	S2-52	S2-52	S2-52	S2-51	S2-52	S2-52
28	Bracket, motor	1	260405	260405	260456	260405	260456	260405	260405
29	Washer	4	300039	300039	300039	300039	300039	300039	300039
30	Screw 5/16-18 x 5/8"	4	S2-52	S2-52	S2-52	S2-52	S2-51	S2-52	S2-52
31	Flange nut 10-32	6	S79-3	S79-3	S79-3	S79-3	S79-3	S79-3	S79-3
32	Spool gear	1	260407	260407	260407	260407	260407	260407	260407
33	Spacer, gear	6	S260410	S260410	S260410	S260410	S260410	S260410	S260410
34	Lock nut 5/16-18	4	S85-7	S85-7	S85-7	S85-7	S85-7	S85-7	S85-7
35	Chain, drive #35	1	S260406	S260406	S260406	S260406	S260406	S260406	S260406
36	Screw 10-31 x 1 1/8"	6	S27-112	S27-112	S27-112	S27-112	S27-112	S27-112	S27-112

ITEM	DESCRIPTION	QTY.	EA33118 L10A	EA33118 L12D	EA33118 M10AX	EA33118 M12D	EA33122 L12D	EA33128 L12D	EA33128 M12D
1	Swivel assembly	1	S602026	S602026	S602026	S602026	S602026	S602026	S602026
2	Screw, 5/16-12 x 5/8"	9	S317-31	S317-31	S317-31	S317-31	S317-31	S317-31	S317-31
3	Side frame	2	260403	260403	260403	260403	260403	260403	260403
5	Nut, 5/16-18	8	S85-7	S85-7	S85-7	S85-7	S85-7	S85-7	S85-7
6	Spool flange	2	S260399-3	S260399-3	S260399-3	S260399-3	S260399-3	S260399-3	S260399-3
7	Snap ring	4	300007	300007	300007	300007	300007	300007	300007
8	Inlet assembly	1	600327-2	600327-2	600327-2	600327-2	600327-2	600327-2	600327-2
9	O-ring	1	S211-120	S211-120	S211-120	S211-120	S211-120	S211-120	S211-120
10	Screw, 5/16-18 x 3/4"	4	S7-51	S7-51	S7-51	S7-51	S7-51	S7-51	S7-51
11	Tie rod	4	260402-300	260402-300	260402-300	260402-300	260402-400	260402-500	260402-500
12	Spacer	4	S260401-3	S260401-3	S260401-3	S260401-3	260401-4	260401-5	260401-5
13	Hub & bushing assembly	3	600640	600640	600640	600640	600640	600640	600640
15	Lock handle assembly	1	S280109	S280109	S280109	S280109	S280109	S280109	S280109
20	Screw, 5/16-18 x 1/2"	8	S2-51	S2-51	S2-51	S2-51	S2-51	S2-51	S2-51
21	Nut, 5/16-18	8	300107	300107	300107	300107	300107	300107	300107
22	Cross brace	2	261501-3	261501-3	261501-3	261501-3	261501-4	261501-5	261501-5
24	Screw, 1/4-20 x 5/8"	3	S2-42	S2-42	S2-42	S2-42	S2-42	S2-42	S2-42
25	Drive motor	1	S260430	S260409	S260430	S260409	S260409	S260409	S260409
26	Gear, motor	1	260434	S260408	260434	S260408	S260408	S260408	S260408
27	Screw 5/16-18 x 5/8"	4	S2-52	S2-52	S2-51	S2-52	S2-52	S2-52	S2-52
28	Bracket, motor	1	260456	260405	260456	260405	260405	260405	260405
29	Washer	4	300039	300039	300039	300039	300039	300039	300039
30	Screw 5/16-18 x 5/8"	4	S2-52	S2-52	S2-51	S2-52	S2-52	S2-52	S2-52
31	Flange nut 10-32	6	S79-3	S79-3	S79-3	S79-3	S79-3	S79-3	S79-3
32	Spool gear	1	260407	260407	260407	260407	260407	260407	260407
33	Spacer, gear	6	S260410	S260410	S260410	S260410	S260410	S260410	S260410
34	Lock nut 5/16-18	4	S85-7	S85-7	S85-7	S85-7	S85-7	S85-7	S85-7
35	Chain, drive #35	1	S260406	S260406	S260406	S260406	S260406	S260406	S260406
36	Screw 10-31 x 1 1/8"	6	S27-112	S27-112	S27-112	S27-112	S27-112	S27-112	S27-112

# Instrucciones de Operacion

## Series 30000 Carretes impulsados por motor eléctricos

EA30106 L10A	EA32118 L12D	EA33112 L10A	EA33122 L12D
EA30112 L12D	EA32118 M12D	EA33112 L12D	EA33128 L12D
EA32106 L10A	EA32118 M24D	EA33112 M10AX	EA33128 M12D
EA32106 L12D	EA32122 L12D	EA33112 M12D	
EA32106 M10A	EA32122 M12D	EA33112 M24D	
EA32106 M12D	EA32128 L12D	EA33118 L10A	
EA32112 L10A	EA32128 M12D	EA33118 L12D	
EA32112 L12D	EA33106 L12D	EA33118 M10AX	
EA32112 M12D	EA33106 M12D	EA33118 M12D	



### Dimensiones

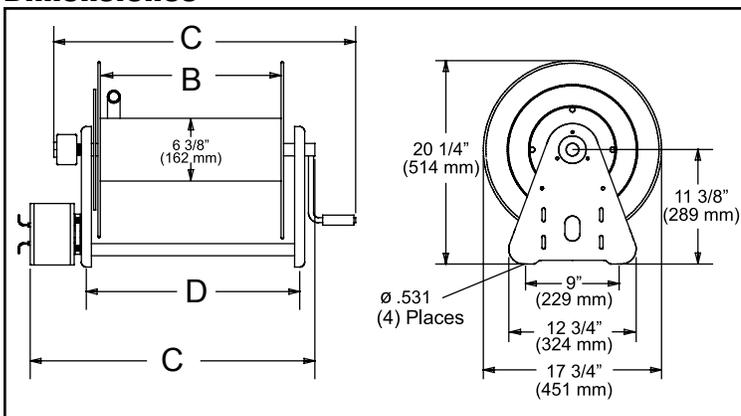

Parte No.	B	C	D	Parte No.	B	C	D
EA30106 L10A	6"	19 5/8"	9 3/4"	EA32128 M12D	27"	38 5/8"	30 3/4"
EA30112 L12D	12"	25 5/8"	15 3/4"	EA33106 L12D	6"	19 5/8"	9 3/4"
EA32106 L10A	6"	19 5/8"	9 3/4"	EA33106 M12D	6"	19 5/8"	9 3/4"
EA32106 L12D	6"	19 5/8"	9 3/4"	EA33112 L10A	12"	25 5/8"	15 3/4"
EA32106 M10A	6"	19 5/8"	9 3/4"	EA33112 L12D	12"	25 5/8"	15 3/4"
EA32106 M12D	6"	19 5/8"	9 3/4"	EA33112 M10AX	12"	25 5/8"	15 3/4"
EA32112 L10A	12"	25 5/8"	15 3/4"	EA33112 M12D	12"	25 5/8"	15 3/4"
EA32112 L12D	12"	25 5/8"	15 3/4"	EA33118 L10A	18"	29 5/8"	21 3/4"
EA32112 M12D	12"	25 5/8"	15 3/4"	EA33118 L12D	18"	29 5/8"	21 3/4"
EA32118 L12D	18"	29 5/8"	21 3/4"	EA33118 M10AX	18"	29 5/8"	21 3/4"
EA32118 M12D	18"	29 5/8"	21 3/4"	EA33118 M12D	18"	29 5/8"	21 3/4"
EA32122 L12D	22"	33 5/8"	25 3/4"	EA33122 L12D	22"	33 5/8"	25 3/4"
EA32122 M12D	22"	33 5/8"	25 3/4"	EA33128 L12D	27"	38 5/8"	30 3/4"
EA32128 L12D	27"	38 5/8"	30 3/4"	EA33128 M12D	27"	38 5/8"	30 3/4"

### Serguridad Personal

Accidentes personales y/o equipos dandados pueden resultar si una de las seguridades apropiadas y percausiones no son observadas.

- Asegurese que el carretel este apropiadamente instalado antes de conectar la linea de provision (leas instrucciones de instalacion).
- Desaloje la presion del fluido/gas del el sistema antes de darle servicio al carretel.
- Antes de conectar el carretel a la linea de provision asegurese que la presion de esta linea de provision ne exeda el maximo de capacidad de presion del carretel.
- No juegue o haga bromas con otra personas. Tambien los gases abaja per-sion son perligrosos y pueden causar danos irreparables o la muerte.
- No use ropa o vestidos sueltos cuando este operando el carretel.
- Este prevenido de otro personal en el area de trabajo.
- Este prevenido de orta maquinaria en el area de trabajo.
- Si una gotera ocurre en la manguera o en el carretel remueva la linead depro- vision de presion de presion inmedi- atamente.
- Si el carretel es de poder motorizado revise por cables sueltos, gastados antes de operar.
- Trate y respete el carretel de manguera- como otra pieza de maquinaria, obser- vando todas las practicas comunes de seguridad.

## INSTRUCCIONES DE INSTALACION

### Inspeccion

Desempaque el carretel y inspeccione por cualquier dano. Gire el carretel con la mano para chequear una operacion suave. Chequee completamente.

### Montaje de todos los carreteles

**NOTA:** Asegurese de que la superficie donde se monta es lisa para prevenir el doblamiento del carretel despues de la montura.

1. Dos de los orificios de ensamblaje d 1/2" de diametro estan hubicados a cada lado de el panel de soporte(dos). Monte el carretel usando cuatro tornil los (proveidos al cliente). Aptietelos para asegurar una solida y rigida union.

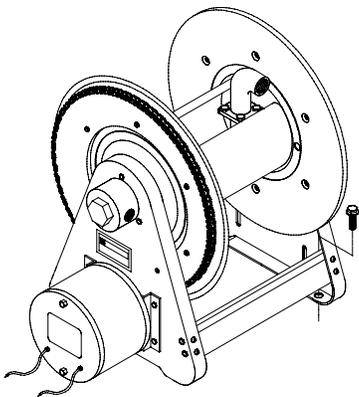

2. Realize los siguientes pasos solamente despues de todos los otros pasos de instalacion pertenecientes a asu carretel en particular, sean realizados.

**NOTA:** Una coneccion de manguera flexible debe de ser para compensar cualquier balance entre la linea de abastesi, iento o provision y el carretel giratorio.

3. Aplique el compuesto para tuercas atodas las tuercas.
4. Inserte la tuerca al conector macho de la linea de abastecimiento dentro del torniquete, apriete seguramente.

**PRECAUCION:** Remueva el poder electrico cuando este haciendo una instalacion electrica, Y NO "Modifique" Observe todas las aplicaciones NECH/OSHA y requerimiento.

5. Asegurese de que el proveedor y la capacidad de voltaje del motor sean compatibles.
6. Consulte el diagrama de conecciones electricas (abajo) y determine cual es aplicable a su carretel.
7. Realize la instalacion electrica del proximo diagrama aplicable.

DOBLE POLO INTERRUPTOR DE UNA VIA

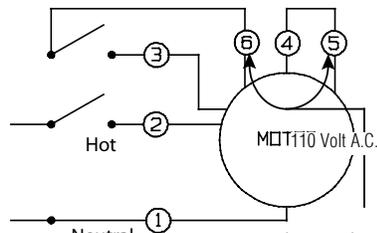

La coneccion mostrada da la toracion en sentido contratio al de las manecillas del reloj. Mire al final del eje del motor. Para invertir la rotacion intercambie los terminales 5,6.

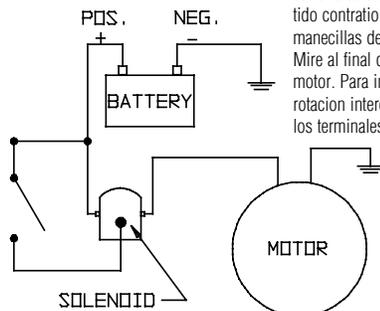

UN POLO INTERRUPTOR DE UNA VIA 12/24 VOLT D.C.

### Conecte La Manguera

**PRECAUCION:** No conecte la manguera al tubo de coneccion montado hasta despues que el carretel de la manguera sea instalado. Extienda completamente y cargue la manguera antes de enrollarla en el carretel. Momentaneamente habra el control de la valvula cuando cargue inicialmente, para purgar la manguera de gases. Cuando el fluido aparece en la valvula de control, cierre la valvula. Esto previne el aplanamiento de la anguera y execiva presion en el tambor curando el abastecimiento de fluidos son reiniziados tiempo mas tarde.

1. Aplique el compuesto para tuercas a todas las tuercas.
2. Inserte manualmente la tuerca al conector macho de la manguera dentro del tubo de coneccion de montaje.
3. Usando una llave de tuercas, sostenga firmemente sobre el tubo de conec-

cion de montaje cuando apriete el conector de la manguera.

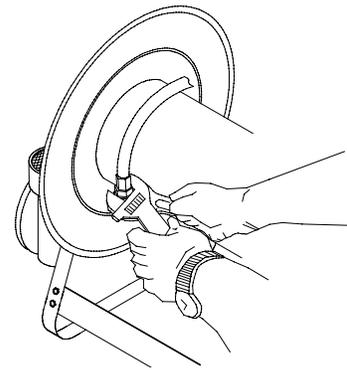

## INSTRUCCIONES DE OPERAMIENTO

### PRECAUCIONES-PREVENCIONES DE CHISPA ESTATICA:

Cuando este trabajando alrededor de liquidos inflamables como solventes, pinturas, quimicos o productos de petroleo, asegurece que el carretel de la manguera, manguera y equipo esten devidamente conectados a tierra. Use la(s) manguera(s) conectadas a tierra (calbes electrico(s) estatico(s)). Use un ohmetro medidor de resistencia electrica para revisar la continuidad del circuito de coneccion a tierra. Fuego y/o explosion pueden resultar si una propia coneccion a tierra no es realizada. Si el carretel es operado con aire a presion tenga cuidado con la cadena dentada manejada presion. Mantenga las manos libres, no use ropa o vestidos sueltos. Hale la mangueras del carretel agarrandola de la misma y no de el control o de el eje giratorio.

## INSTRUCCIONES DE SERVICIO

### Reemplazo De La Manguera

1. Usando un llave de tuercas, firmemente sugete el tubo de conecicon de montaje por untiempo removiendo el conector de manguera.
2. Siga el proceso para "Conecciones de manguera" (mire intrucciones de instalacion).

### Reemplazando El Eje Giratorio

**PRECAUCION:** Remueva la linea de abastecimiento de presion minentras realiza el siguiente procedimiento.

1. Remueva la linea de abastecimiento del eje giratorio.
2. Remueva el eje de montaje del eje giratorio la entrada de el tunel o hueco origicio del eje.
3. Instale el montaje del eje firatorio dentro de el tunel del eje devolviendose por os pasos 2,1. Aplique compnente de tuercas a todas las tuercas.

### Reemplazo Del Motor

**PRECAUCION:** Antes de reemplazar el motor remueva todo el poder electrico o presion de aire de el motor.

1. Desconecte cables electricos, lineas de aire de el motor.
2. Remueva los tornillos asegurando el motor al montaje de soporte de el carretel. Remueva el soporte (mire el diagrama en la siguiente paguina).
3. Instale el motor nuevo devolviendose por los pasos de 1 a 3 arriba mencionados.

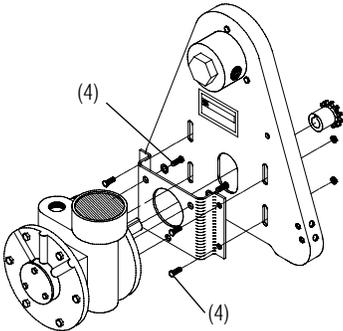

### Reemplazando La Cadena

**PRECAUCION:** Antes de reemplazar la cadena remueva o apague todo el poder electrico (motor electrico) de el motor.

1. Suelte (sin remover) los tornillos de seguridad monte los soportes en lugar.
2. Remueva el eslabon principal de la cadena.
3. Instale la cadena nueva invirtiendo los pasos 1 y 2 arriba mencionados.

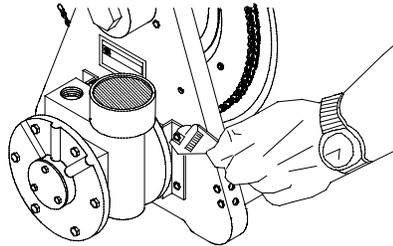

2. Mueva el soporte del montaje del motor hasta obtener una tension apropiada.
3. Apriete los tornillos de los soportes de montaje.

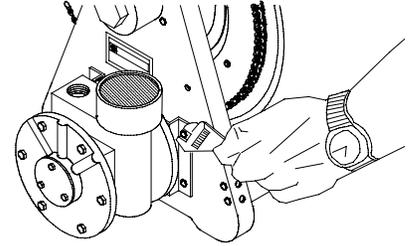

### Procedimiento De Ajustamiento Ajustamiento del carretel

1. Ajustar el dispositivo de seguridad del carretel desagustando y ajustando el conjunto de tornillos en la cubierta, en los carreteles conducidos manualmente.

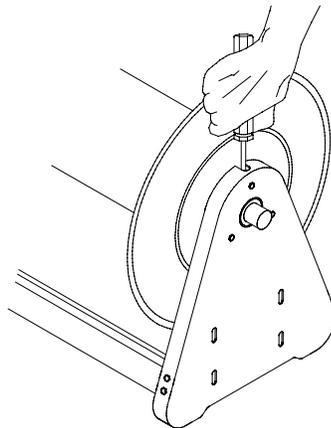

### Ajustamiento De La Cadena De Tension

**PRECAUCION:** Antes de ajustar la tension de la cadena remueva o apague el poder elctrico (motor electrico) o de el motor. Exeso de tension de la cadena reduce la vida del motor. Ajuste y deje entre 1/4 y 1/2 inchas de cadena.

1. Suelte la s tuercas (no remueva) asegure los soportes de montaje del carretel.

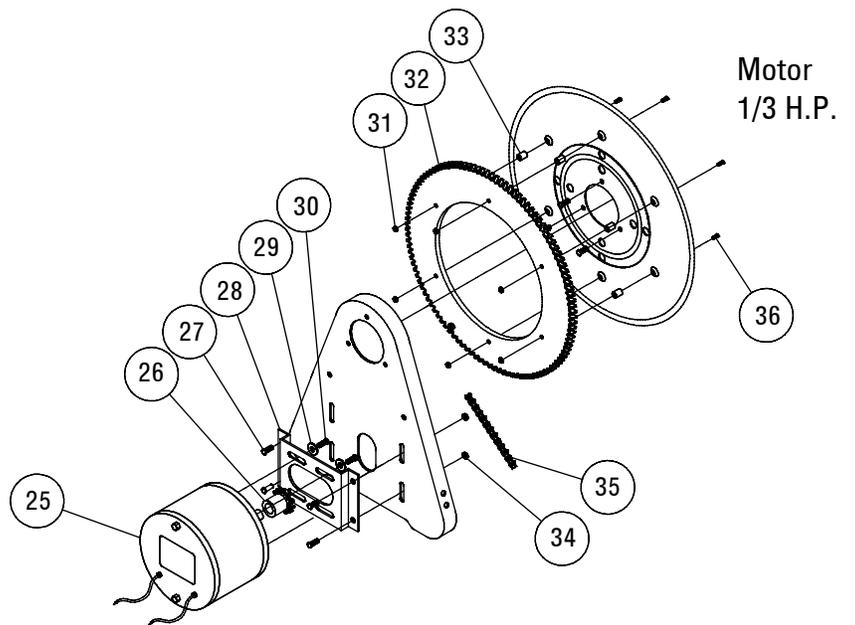
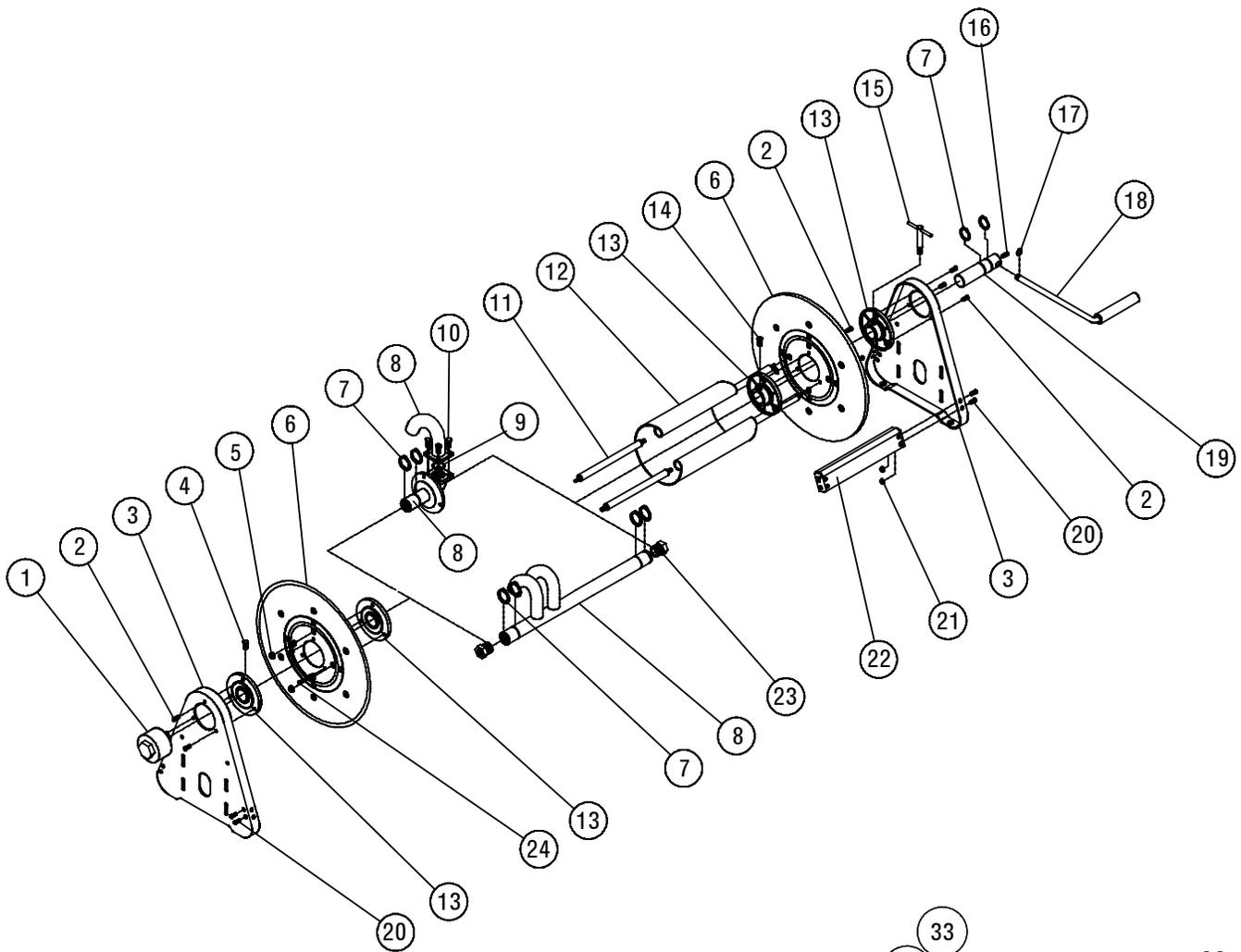

Motor a Prueba de Explosion  
1/2 HP

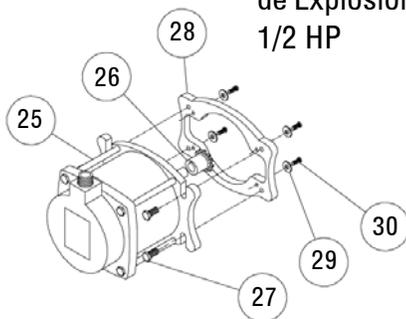

Series 30000 Carretes impulsados por motor eléctricos

ARTICULO	DESCRIPCION	CTD	EA30106 L10A	EA30112 L12D	EA32106 L10A	EA32106 L12D	EA32106 M10A	EA32106 M12D	EA32112 L10A	EA32112 L12D
1	Ensamblaje del eje giratoria	1	-----	-----	600888	600888	S602033	S602033	600888	600888
2	Tornillo, 5/16-12 x 5/8"	9	S317-31	S317-31	S317-31	S317-31	S317-31	S317-31	S317-31	S317-31
3	Lado el marco	2	260403	260403	260403	260403	260403	260403	260403	260403
5	Tuerca, 5/16-18	8	S85-7	S85-7	S85-7	S85-7	S85-7	S85-7	S85-7	S85-7
6	Platillo del carretel	2	S260399-3	S260399-3	S260399-3	S260399-3	S260399-3	S260399-3	S260399-3	S260399-3
7	Aro de resorte	4	300007	300007	300007	300007	300007	300007	300007	300007
8	Ensamblaje de entrada	1	600327-2	600327-2	600327-1	600327-1	600327-1	600327-1	600327-1	600327-1
9	Arendela	1	S211-120	S211-120	S211-120	S211-120	S211-120	S211-120	S211-120	S211-120
10	Tornilla, 5/16-18 x 3/4"	4	S7-51	S7-51	S7-51	S7-51	S7-51	S7-51	S7-51	S7-51
11	Separador	4	260402-100	260402-200	260402-100	260402-100	260402-100	260402-100	260402-200	260402-200
12	Espaciador	4	260401-1	260401-2	260401-1	260401-1	260401-1	260401-1	260401-2	260401-2
13	Ensamblaje de la campana y boquilla	3	S600640	S600640	S600640	S600640	S600640	S600640	S600640	S600640
15	Ensamblaje del seguro de la manija	1	S280109	S280109	S280109	S280109	S280109	S280109	S280109	S280109
20	Tornillo, 5/16-18 x 1/2"	8	S2-51	S2-51	S2-51	S2-51	S2-51	S2-51	S2-51	S2-51
21	Tuerca, 5/16-18	8	300107	300107	300107	300107	300107	300107	300107	300107
22	Miembro cruzado	2	261501-1	261501-2	261501-1	261501-1	261501-1	261501-1	261501-2	261501-2
24	Tornillo, 1/4-20 x 5/8"	3	S2-42	S2-42	S2-42	S2-42	S2-42	S2-42	S2-42	S2-42
25	Accionado con motor	1	S260430	S260409	S260430	S260409	S260430	S260409	S260430	S260409
26	Engranaje del motor	1	260434	S260408	260434	S260408	260434	S260408	260434	260408
27	Tornillo 5/16-18 x 5/8"	4	S2-52	S2-52	S2-52	S2-52	S2-52	S2-52	S2-52	S2-52
28	Soprote del motor	1	260456	260405	260456	260405	260456	260405	260456	260405
29	Arandela	4	300039	300039	300039	300039	300039	300039	300039	300039
30	Tornillo 5/16-18 x 5/8"	4	S2-52	S2-52	S2-52	S2-52	S2-52	S2-52	S2-52	S2-52
31	10-32 Tuerca de reborde	6	S79-3	S79-3	S79-3	S79-3	S79-3	S79-3	S79-3	S79-3
32	Engranaje del carretel	1	260407	260407	260407	260407	260407	260407	260407	260407
33	Separador del engranaje	6	S260410	S260410	S260410	S260410	S260410	S260410	S260410	S260410
34	5/16-18 Tuerca de reborde	4	S85-7	S85-7	S85-7	S85-7	S85-7	S85-7	S85-7	S85-7
35	Cadena no. 35	1	S260406	S260406	S260406	S260406	S260406	S260406	S260406	S260406
36	Tornillo 10-31 x 1 1/8"	6	S27-112	S27-112	S27-112	S27-112	S27-112	S27-112	S27-112	S27-112

ARTICULO	DESCRIPCION	CTD	EA32112 M12D	EA32118 L12D	EA32118 M12D	EA32118 M24D	EA32122 L12D	EA32122 M12D	EA32128 L12D	EA32128 M12D
1	Ensamblaje del eje giratoria	1	S602033	600888	S602033	S602033	600888	S602033	600888	S602033
2	Tornillo, 5/16-12 x 5/8"	9	S317-31	S317-31	S317-31	S317-31	S317-31	S317-31	S317-31	S317-31
3	Lado el marco	2	260403	260403	260403	260403	260403	260403	260403	260403
5	Tuerca, 5/16-18	8	S85-7	S85-7	S85-7	S85-7	S85-7	S85-7	S85-7	S85-7
6	Platillo del carretel	2	S260399-3	S260399-3	S260399-3	S260399-3	S260399-3	S260399-3	S260399-3	S260399-3
7	Aro de resorte	4	300007	300007	300007	300007	300007	300007	300007	300007
8	Ensamblaje de entrada	1	600327-1	600327-1	600327-1	600327-1	600327-1	600327-1	600327-1	600327-1
9	Arendela	1	S211-120	S211-120	S211-120	S211-120	S211-120	S211-120	S211-120	S211-120
10	Tornilla, 5/16-18 x 3/4"	4	S7-51	S7-51	S7-51	S7-51	S7-51	S7-51	S7-51	S7-51
11	Separador	4	260402-200	260402-300	260402-300	260402-300	260402-400	260402-400	260402-500	260402-500
12	Espaciador	4	260401-2	S260401-3	S260401-3	S260401-3	260401-4	260401-4	260401-5	260401-5
13	Ensamblaje de la campana y boquilla	3	S600640	S600640	S600640	S600640	S600640	S600640	S600640	S600640
15	Ensamblaje del seguro de la manija	1	S280109	S280109	S280109	S280109	S280109	S280109	S280109	S280109
20	Tornillo, 5/16-18 x 1/2"	8	S2-51	S2-51	S2-51	S2-51	S2-51	S2-51	S2-51	S2-51
21	Tuerca, 5/16-18	8	300107	300107	300107	300107	300107	300107	300107	300107
22	Miembro cruzado	2	261501-2	261501-3	261501-3	261501-3	261501-4	261501-4	261501-5	261501-5
24	Tornillo, 1/4-20 x 5/8"	3	S2-42	S2-42	S2-42	S2-42	S2-42	S2-42	S2-42	S2-42
25	Accionado con motor	1	S260409	S260409	S260409	260450	S260409	S260409	S260409	S260409
26	Engranaje del motor	1	S260408	S260408	S260408	S260408	S260408	S260408	S260408	S260408
27	Tornillo 5/16-18 x 5/8"	4	S2-52	S2-52	S2-52	S2-52	S2-52	S2-52	S2-52	S2-52
28	Soprote del motor	1	260405	260405	260405	260405	260405	260405	260405	260405
29	Arandela	4	300039	300039	300039	300039	300039	300039	300039	300039
30	Tornillo 5/16-18 x 5/8"	4	S2-52	S2-52	S2-52	S2-52	S2-52	S2-52	S2-52	S2-52
31	10-32 Tuerca de reborde	6	S79-3	S79-3	S79-3	S79-3	S79-3	S79-3	S79-3	S79-3
32	Engranaje del carretel	1	260407	260407	260407	260407	260407	260407	260407	260407
33	Separador del engranaje	6	S260410	S260410	S260410	S260410	S260410	S260410	S260410	S260410
34	5/16-18 Tuerca de reborde	4	S85-7	S85-7	S85-7	S85-7	S85-7	S85-7	S85-7	S85-7
35	Cadena no. 35	1	S260406	S260406	S260406	S260406	S260406	S260406	S260406	S260406
36	Tornillo 10-31 x 1 1/8"	6	S27-112	S27-112	S27-112	S27-112	S27-112	S27-112	S27-112	S27-112

Series 30000 Carretes impulsados por motor eléctricos

ARTICULO	DESCRIPCION	CTD	EA33106 L12D	EA33106 M12D	EA33112 L10A	EA33112 L12D	EA33112 M10AX	EA33112 M12D	EA33112 M24D
1	Ensamblaje del eje giratoria	1	S602026	S602026	S602026	S602026	S602026	S602026	S602026
2	Tornillo, 5/16-12 x 5/8"	9	S317-31	S317-31	S317-31	S317-31	S317-31	S317-31	S317-31
3	Lado el marco	2	260403	260403	260403	260403	260403	260403	260403
5	Tuerca, 5/16-18	8	S85-7	S85-7	S85-7	S85-7	S85-7	S85-7	S85-7
6	Platillo del carretel	2	S260399-3	S260399-3	S260399-3	S260399-3	S260399-3	S260399-3	S260399-3
7	Aro de resorte	4	300007	300007	300007	300007	300007	300007	300007
8	Ensamblaje de entrada	1	600327-2	600327-2	600327-2	600327-2	600327-2	600327-2	600327-2
9	Arendela	1	S211-120	S211-120	S211-120	S211-120	S211-120	S211-120	S211-120
10	Tornilla, 5/16-18 x 3/4"	4	S7-51	S7-51	S7-51	S7-51	S7-51	S7-51	S7-51
11	Separador	4	260402-100	260402-100	260402-200	260402-200	260402-200	260402-200	260402-200
12	Espaciador	4	260401-1	260401-1	260401-2	260401-2	260401-2	260401-2	260401-2
13	Ensamblaje de la campana y boquilla	3	S600640	S600640	S600640	S600640	S600640	S600640	S600640
15	Ensamblaje del seguro de la manija	1	S280109	S280109	S280109	S280109	S280109	S280109	S280109
20	Tornillo, 5/16-18 x 1/2"	8	S2-51	S2-51	S2-51	S2-51	S2-51	S2-51	S2-51
21	Tuerca, 5/16-18	8	300107	300107	300107	300107	300107	300107	300107
22	Miembro cruzado	2	261501-1	261501-1	261501-2	261501-2	261501-2	261501-2	261501-2
24	Tornillo, 1/4-20 x 5/8"	3	S2-42	S2-42	S2-42	S2-42	S2-42	S2-42	S2-42
25	Accionado con motor	1	S260409	S260409	S260430	S260409	S260430	S260409	260450
26	Engranaje del motor	1	S260408	S260408	260434	S260408	260434	S260408	S260408
27	Tornillo 5/16-18 x 5/8"	4	S2-52	S2-52	S2-52	S2-52	S2-51	S2-52	S2-52
28	Soprote del motor	1	260405	260405	260456	260405	260456	260405	260405
29	Arandela	4	300039	300039	300039	300039	300039	300039	300039
30	Tornillo 5/16-18 x 5/8"	4	S2-52	S2-52	S2-52	S2-52	S2-51	S2-52	S2-52
31	10-32 Tuerca de reborde	6	S79-3	S79-3	S79-3	S79-3	S79-3	S79-3	S79-3
32	Engranaje del carretel	1	260407	260407	260407	260407	260407	260407	260407
33	Separador del engranaje	6	S260410	S260410	S260410	S260410	S260410	S260410	S260410
34	5/16-18 Tuerca de reborde	4	S85-7	S85-7	S85-7	S85-7	S85-7	S85-7	S85-7
35	Cadena no. 35	1	S260406	S260406	S260406	S260406	S260406	S260406	S260406
36	Tornillo 10-31 x 1 1/8"	6	S27-112	S27-112	S27-112	S27-112	S27-112	S27-112	S27-112

ARTICULO	DESCRIPCION	CTD	EA33118 L10A	EA33118 L12D	EA33118 M10AX	EA33118 M12D	EA33122 L12D	EA33128 L12D	EA33128 M12D
1	Ensamblaje del eje giratoria	1	S602026	S602026	S602026	S602026	S602026	S602026	S602026
2	Tornillo, 5/16-12 x 5/8"	9	S317-31	S317-31	S317-31	S317-31	S317-31	S317-31	S317-31
3	Lado el marco	2	260403	260403	260403	260403	260403	260403	260403
5	Tuerca, 5/16-18	8	S85-7	S85-7	S85-7	S85-7	S85-7	S85-7	S85-7
6	Platillo del carretel	2	S260399-3	S260399-3	S260399-3	S260399-3	S260399-3	S260399-3	S260399-3
7	Aro de resorte	4	300007	300007	300007	300007	300007	300007	300007
8	Ensamblaje de entrada	1	600327-2	600327-2	600327-2	600327-2	600327-2	600327-2	600327-2
9	Arendela	1	S211-120	S211-120	S211-120	S211-120	S211-120	S211-120	S211-120
10	Tornilla, 5/16-18 x 3/4"	4	S7-51	S7-51	S7-51	S7-51	S7-51	S7-51	S7-51
11	Separador	4	260402-300	260402-300	260402-300	260402-300	260402-400	260402-500	260402-500
12	Espaciador	4	S260401-3	S260401-3	S260401-3	S260401-3	260401-4	260401-5	260401-5
13	Ensamblaje de la campana y boquilla	3	600640	600640	600640	600640	600640	600640	600640
15	Ensamblaje del seguro de la manija	1	S280109	S280109	S280109	S280109	S280109	S280109	S280109
20	Tornillo, 5/16-18 x 1/2"	8	S2-51	S2-51	S2-51	S2-51	S2-51	S2-51	S2-51
21	Tuerca, 5/16-18	8	300107	300107	300107	300107	300107	300107	300107
22	Miembro cruzado	2	261501-3	261501-3	261501-3	261501-3	261501-4	261501-5	261501-5
24	Tornillo, 1/4-20 x 5/8"	3	S2-42	S2-42	S2-42	S2-42	S2-42	S2-42	S2-42
25	Accionado con motor	1	S260430	S260409	S260430	S260409	S260409	S260409	S260409
26	Engranaje del motor	1	260434	S260408	260434	S260408	S260408	S260408	S260408
27	Tornillo 5/16-18 x 5/8"	4	S2-52	S2-52	S2-51	S2-52	S2-52	S2-52	S2-52
28	Soprote del motor	1	260456	260405	260456	260405	260405	260405	260405
29	Arandela	4	300039	300039	300039	300039	300039	300039	300039
30	Tornillo 5/16-18 x 5/8"	4	S2-52	S2-52	S2-51	S2-52	S2-52	S2-52	S2-52
31	10-32 Tuerca de reborde	6	S79-3	S79-3	S79-3	S79-3	S79-3	S79-3	S79-3
32	Engranaje del carretel	1	260407	260407	260407	260407	260407	260407	260407
33	Separador del engranaje	6	S260410	S260410	S260410	S260410	S260410	S260410	S260410
34	5/16-18 Tuerca de reborde	4	S85-7	S85-7	S85-7	S85-7	S85-7	S85-7	S85-7
35	Cadena no. 35	1	S260406	S260406	S260406	S260406	S260406	S260406	S260406
36	Tornillo 10-31 x 1 1/8"	6	S27-112	S27-112	S27-112	S27-112	S27-112	S27-112	S27-112

# Instructions D'Opération

## Série 30000 Enrouleurs Électriques

EA30106 L10A	EA32118 L12D	EA33112 L10A	EA33122 L12D
EA30112 L12D	EA32118 M12D	EA33112 L12D	EA33128 L12D
EA32106 L10A	EA32118 M24D	EA33112 M10AX	EA33128 M12D
EA32106 L12D	EA32122 L12D	EA33112 M12D	
EA32106 M10A	EA32122 M12D	EA33112 M24D	
EA32106 M12D	EA32128 L12D	EA33118 L10A	
EA32112 L10A	EA32128 M12D	EA33118 L12D	
EA32112 L12D	EA33106 L12D	EA33118 M10AX	
EA32112 M12D	EA33106 M12D	EA33118 M12D	



### Dimensional Data

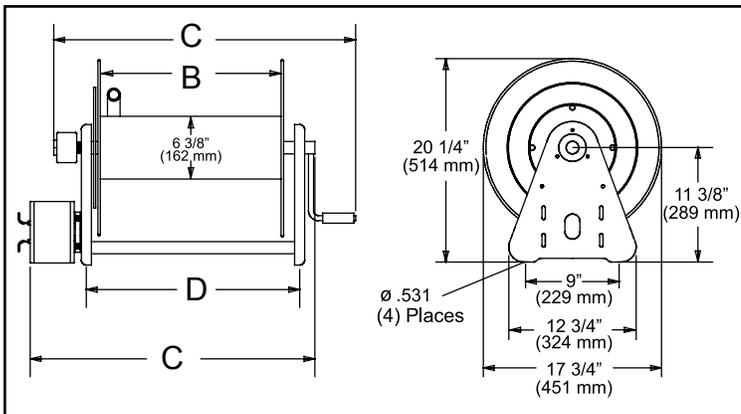

N° de pièce	B	C	D	N° de pièce	B	C	D
EA30106 L10A	6"	19 5/8"	9 3/4"	EA32128 M12D	27"	38 5/8"	30 3/4"
EA30112 L12D	12"	25 5/8"	15 3/4"	EA33106 L12D	6"	19 5/8"	9 3/4"
EA32106 L10A	6"	19 5/8"	9 3/4"	EA33106 M12D	6"	19 5/8"	9 3/4"
EA32106 L12D	6"	19 5/8"	9 3/4"	EA33112 L10A	12"	25 5/8"	15 3/4"
EA32106 M10A	6"	19 5/8"	9 3/4"	EA33112 L12D	12"	25 5/8"	15 3/4"
EA32106 M12D	6"	19 5/8"	9 3/4"	EA33112 M10AX	12"	25 5/8"	15 3/4"
EA32112 L10A	12"	25 5/8"	15 3/4"	EA33112 M12D	12"	25 5/8"	15 3/4"
EA32112 L12D	12"	25 5/8"	15 3/4"	EA33112 M24D	12"	25 5/8"	15 3/4"
EA32112 M12D	12"	25 5/8"	15 3/4"	EA33118 L10A	18"	29 5/8"	21 3/4"
EA32118 L12D	18"	29 5/8"	21 3/4"	EA33118 L12D	18"	29 5/8"	21 3/4"
EA32118 M12D	18"	29 5/8"	21 3/4"	EA33118 M10AX	18"	29 5/8"	21 3/4"
EA32118 M24D	18"	29 5/8"	21 3/4"	EA33118 M12D	18"	29 5/8"	21 3/4"
EA32122 L12D	22"	33 5/8"	25 3/4"	EA33122 L12D	22"	33 5/8"	25 3/4"
EA32122 M12D	22"	33 5/8"	25 3/4"	EA33128 L12D	27"	38 5/8"	30 3/4"
EA32128 L12D	27"	38 5/8"	30 3/4"	EA33128 M12D	27"	38 5/8"	30 3/4"

### La Sécurité du Personnel

Blessure personnel et/ou le dommage d'équipement peut résulter si les précautions de sécurité ne sont pas observées.

- Assurez-vous que l'enrouleur est installé comme il faut avant de connecter le tuyau d'alimentation (voyez les instructions d'installation).
- Évacuez du système la pression de fluide/ combustible avant de faire le service.
- Avant de connecter l'enrouleur au tuyau d'alimentation, assurez-vous que la pression ne dépasse pas la pression maximum pour l'enrouleur.
- Ne jouez pas un tour aux autres personnel. Même la basse pression est très dangereuse et elle peut causer le dommage irréparable ou le mort.
- Ne portez pas des vêtements amples en utilisant l'enrouleur.
- Soyez conscient d'autres personnels au travaille.
- Soyez conscient d'autres machines au travaille.
- Si le tuyau ou l'enrouleur se met à fuir, évacuez la pression du système immédiatement.
- Si l'enrouleur fonctionne à l'électricité, vérifiez que les fils ne sont pas effilochés ou cassés avant chaque utilisation.
- Comme tout d'autres machines, repectez et utilisez avec soin l'enrouleur. Observez tous les pratiques de sécurité.

## INSTRUCTIONS D'INSTALLATION

### Inspection

Déballiez et inspectez l'enrouleur pour déceler le dommage s'il existe. Faites tourner l'enrouleur à la main pour vérifier le bon fonctionnement.

### Montage de tous enrouleurs

**NOTEZ:** Assurez-vous que la surface de montage est plate pour éviter le coincement du tuyau après l'enrouleur est monté.

1. Deux trous de montage du diamètre 1/2" se trouvent au base de chaque-support de côté (2 pour chaque). Montez l'enrouleur avec 4 boulons (fournis par le client). Serrez-les bien pour assurer une fixation solide.

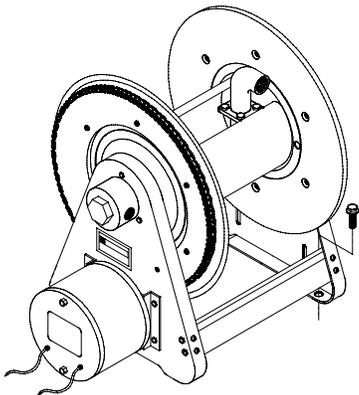

2. Faites les étapes suivantes après toutes autres instructions d'installations sont faites pour votre enrouleur en particulier.

**NOTEZ:** Un raccord flexible doit être utilisé pour compenser entre le tuyau et le pivot.

3. Appliquez du matériau d'étanchéité à tous les filets.
4. Enfilez le raccord mâle de la ligne d'alimentation au pivot. Serrez bien.

**PRÉCAUTION:** Éliminez toute pouvoir électrique avant de câbler. Observez toutes les requises de NEC/OSHA.

5. Assurez-vous que le classement du voltage d'alimentation est compatible avec ce du motuer.
6. Référez aux diagrammes ci-dessous pour déterminer lequel applique à votre enrouleur.
4. Câblez l'enrouleur d'après le diagramme applicable.

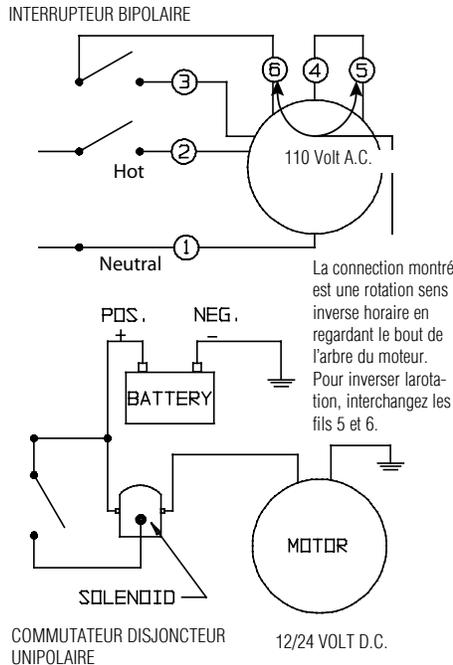

### Connexion du tuyau

**PRÉCAUTION:** Ne connectez pas le tuyau à l'assemblage du tubulure de raccord avant d'installer l'enrouleur de tuyau.

Étendez entièrement le tuyau et remplissez-le avant d'enrouler sur l'enrouleur. Ouvrez momentanément la vanne de régulation, fermez-la. Cela évite l'aplatissage du tuyau et la pression excessive quand vous utilisez l'enrouleur plus tard.

1. Appliquez du matériau d'étanchéité à tous les filets.
2. Enfilez le raccord mâle à l'assemblage de tubulure de raccord.
3. Avec une clef, serrez bien ce raccord pendant que vous tenez bien l'assemblage de tubulure de raccord.

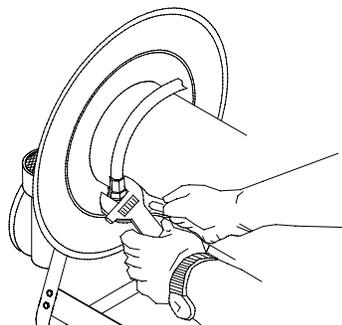

## INSTRUCTIONS D'OPÉRATION

### AVERTISSEMENT - ÉVITEZ LA

**CHARGE STATIQUE:** Quand vous travaillez près des liquides combustibles come des dissolvants, des penitures, des produits chimiques, ou des produits de pétroles, assurez-vous que l'enrouleur, le tuyau, et l'équipement sont tous mis à terre. Utilisez des tuyaux mis à terre. Utilisez un ohmmètre pour vérifier la continuité du circuit. Si l'enrouleur n'est pas correctement mis à terre, un feu ou une explosion peut résulter. Si l'enrouleur fonctionne à l'air ou à l'électricité, soyez prudent du système de chaîne/de pignon. Tenez vos mains loin du système. Ne portez pas des vêtements amples. Tirez le tuyau de l'enrouleur en empoignant le tuyau, et non pas la poignée de régulation ni le pivot.

## INSTRUCTIONS D'ENTRETIEN

### Remplacement des tuyaux

1. Avec une clef, tenez bien l'assemblage de tubulure de raccord pendant que vous enlevez le raccord.
2. Suivez les procédés pour "La raccordement de Tuyau" (Voyez les Instructions d'Installation).

### Remplacement de Pivot

**PRÉCAUTION:** Enlevez la pression du tuyau avant de faire le procédé suivant.

1. Enlevez le tuyau du pivot.
2. Enlevez l'assemblage du pivot de l'arbre d'entrée.
3. Installez l'assemblage de pivot à l'arbre d'entrée en faisant les étapes 1 à 2 par ordre inverse. Appliquez du matériau d'étanchéité à tous les filets.

## Remplacement de Moteur

**PRÉCAUTION:** Avant de remplacer le moteur, débranchez l'électricité du moteur.

1. Débranchez le filage/les tuyaux d'air du moteur.
2. Enlevez les boulons qui sécurisent le support de montage du moteur à l'enrouleur. Enlevez le support (Voyez le diagramme à la page suivante).
3. Installez le nouveau moteur en faisant les étapes 1 à 3 ci-dessus par ordre inverse.

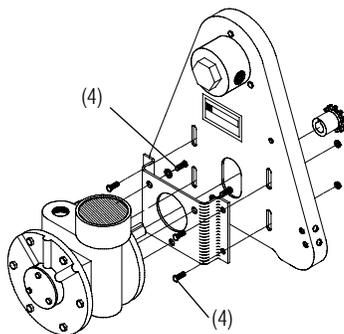

## Remplacement de Chaîne

**PRÉCAUTION:** Avant de remplacer la chaîne, débranchez du moteur toute l'électricité.

1. Déserrez les boulons (mais ne les enlevez pas) qui sécurisent en place le support de montage du moteur.
2. Enlevez l'articulation principale de la chaîne.
3. Installez la nouvelle chaîne en faisant les étapes 1 et 2 ci-dessus par ordre inverse.

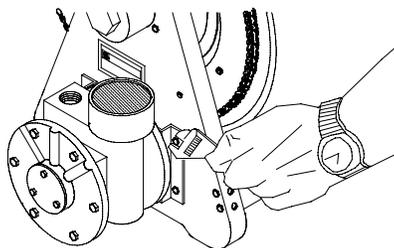

## PROCÉDÉS DE RÉGLAGES

### Réglage de l'Enrouleur

1. Réglez la résistance en serrant ou en desserrant la vis sans tête qui se trouve sur le moyeu sur les enrouleurs manuels.

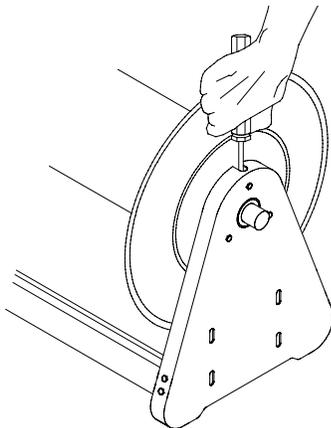

### Réglage de la résistance de la chaîne

**PRÉCAUTION:** Avant de régler la résistance de la chaîne, débranchez du moteur toute l'électricité. Une chaîne qui est trop tendue réduit la vie du moteur. Réglez la tension pour que la chaîne soit détendue entre 1/4 et 1/2 pouce.

1. Déserrez les boulons (mais ne les enlevez pas) qui sécurisent le support de montage du moteur à l'enrouleur.
2. Placez le support et le moteur jusqu'à l'obtention de la tension désirée de la chaîne.
3. Serrez les boulons du support.

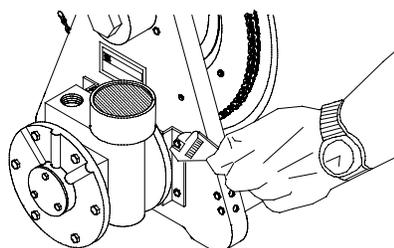

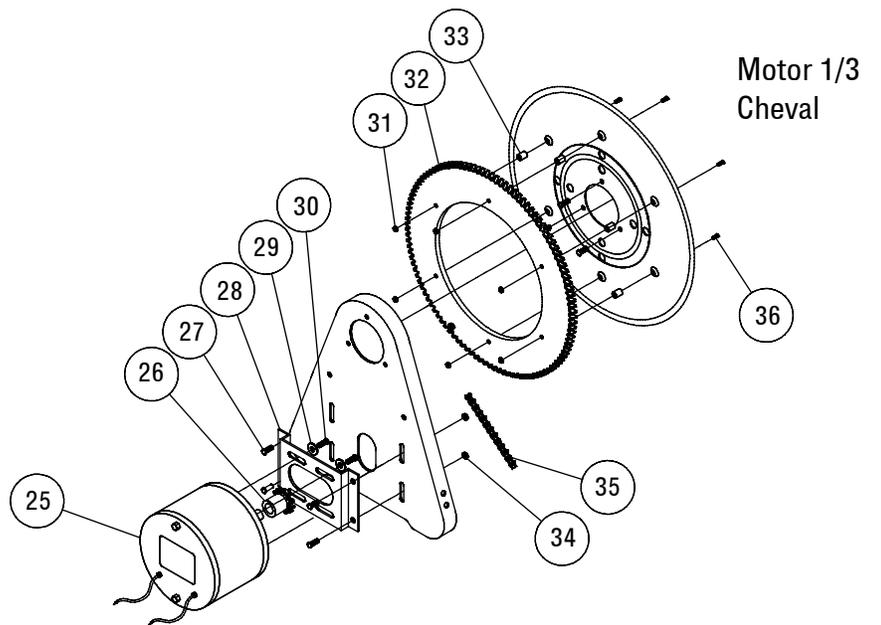
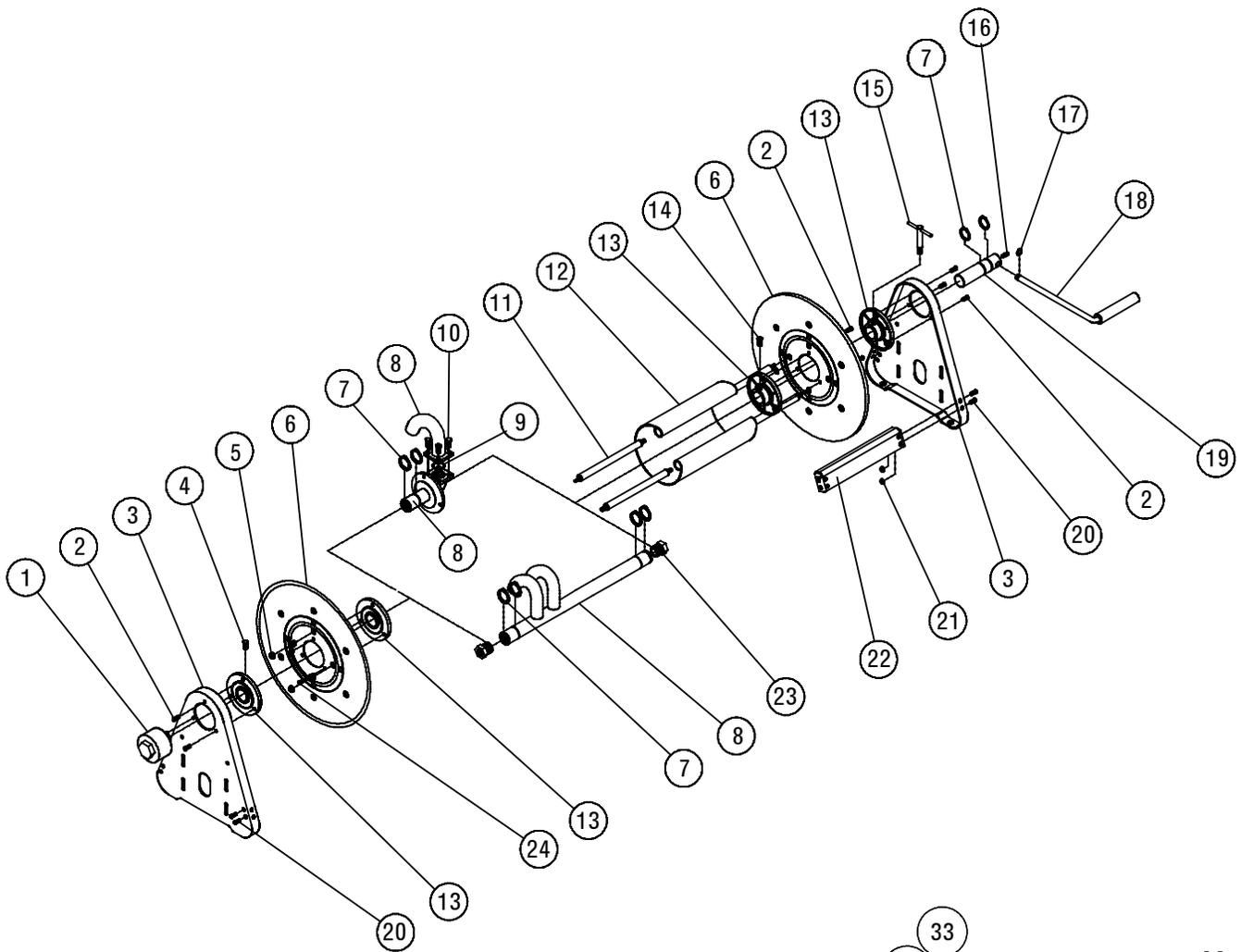

Motor 1/3 Cheval

Motor Anti-Deflagrant 1/2 Cheval

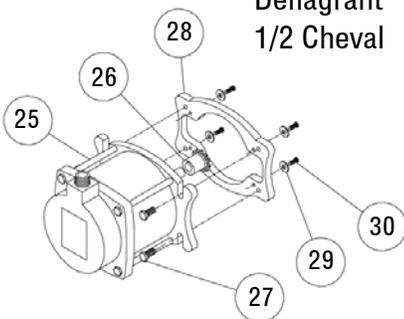

## Série 30000 enrouleurs électriques

Article	DESCRIPTION	Quantité	EA30106 L10A	EA30112 L12D	EA32106 L10A	EA32106 L12D	EA32106 M10A	EA32106 M12D	EA32112 L10A	EA32112 L12D
1	Assemblage de pivot	1	-----	-----	600888	600888	602033	602033	600888	600888
2	Vis, 5/16-12 x 5/8"	9	S317-31	S317-31	S317-31	S317-31	S317-31	S317-31	S317-31	S317-31
3	Cadre Latéral	2	260403	260403	260403	260403	260403	260403	260403	260403
5	Écrou, 5/16-18	8	S85-7	S85-7	S85-7	S85-7	S85-7	S85-7	S85-7	S85-7
6	Tambour bridé	2	260399-3	260399-3	260399-3	260399-3	260399-3	260399-3	260399-3	260399-3
7	Dispositif de retenue	4	300007	300007	300007	300007	300007	300007	300007	300007
8	Assemblage d'entrée	1	600327-2	600327-2	600327-1	600327-1	600327-1	600327-1	600327-1	600327-1
9	Anneau en "O"	1	S211-120	S211-120	S211-120	S211-120	S211-120	S211-120	S211-120	S211-120
10	Vis, 5/16-18 x 3/4"	4	S7-51	S7-51	S7-51	S7-51	S7-51	S7-51	S7-51	S7-51
11	Farre d'accouplement	4	260402-100	260402-200	260402-100	260402-100	260402-100	260402-100	260402-200	260402-200
12	Pièce d'espacement	4	260401-1	260401-2	260401-1	260401-1	260401-1	260401-1	260401-2	260401-2
13	Assemblage de moyeu et manchon	3	600640	600640	600640	600640	600640	600640	600640	600640
15	Assemblage de manche loquant	1	280109	280109	280109	280109	280109	280109	280109	280109
20	Vis, 5/16-18 x 1/2"	8	S2-51	S2-51	S2-51	S2-51	S2-51	S2-51	S2-51	S2-51
21	Écrou, 5/16-18	8	300107	300107	300107	300107	300107	300107	300107	300107
22	Traverse	2	261501-1	261501-2	261501-1	261501-1	261501-1	261501-1	261501-2	261501-2
24	Vis, 1/4-20 x 5/8"	3	S2-42	S2-42	S2-42	S2-42	S2-42	S2-42	S2-42	S2-42
25	Moteur	1	260430	260409	260430	260409	260430	260409	260430	260409
26	Moteur à engrenages	1	260434	260408	260434	260408	260434	260408	260434	260408
27	Vis 5/16-18 x 5/8"	4	S2-52	S2-52	S2-52	S2-52	S2-52	S2-52	S2-52	S2-52
28	Support de moteur	1	260456	260405	260456	260405	260456	260405	260456	260405
29	Rondelle	4	300039	300039	300039	300039	300039	300039	300039	300039
30	Vis 5/16-18 x 5/8"	4	S2-52	S2-52	S2-52	S2-52	S2-52	S2-52	S2-52	S2-52
31	Écrou à embase 10-32	6	S79-3	S79-3	S79-3	S79-3	S79-3	S79-3	S79-3	S79-3
32	Engrenages de tambour	1	260407	260407	260407	260407	260407	260407	260407	260407
33	Entretoise	6	260410	260410	260410	260410	260410	260410	260410	260410
34	Écrou à embase 5/16-18	4	S85-7	S85-7	S85-7	S85-7	S85-7	S85-7	S85-7	S85-7
35	Tambour bridé	1	260406	260406	260406	260406	260406	260406	260406	260406
36	Vis 10-31 x 1 1/8"	6	S27-112	S27-112	S27-112	S27-112	S27-112	S27-112	S27-112	S27-112

Article	DESCRIPTION	Quantité	EA32112 M12D	EA32118 L12D	EA32118 M12D	EA32118 M24D	EA32122 L12D	EA32122 M12D	EA32128 L12D	EA32128 M12D
1	Assemblage de pivot	1	602033	600888	602033	602033	600888	602033	600888	602033
2	Vis, 5/16-12 x 5/8"	9	S317-31	S317-31	S317-31	S317-31	S317-31	S317-31	S317-31	S317-31
3	Cadre Latéral	2	260403	260403	260403	260403	260403	260403	260403	260403
5	Écrou, 5/16-18	8	S85-7	S85-7	S85-7	S85-7	S85-7	S85-7	S85-7	S85-7
6	Tambour bridé	2	260399-3	260399-3	260399-3	260399-3	260399-3	260399-3	260399-3	260399-3
7	Dispositif de retenue	4	300007	300007	300007	300007	300007	300007	300007	300007
8	Assemblage d'entrée	1	600327-1	600327-1	600327-1	600327-1	600327-1	600327-1	600327-1	600327-1
9	Anneau en "O"	1	S211-120	S211-120	S211-120	S211-120	S211-120	S211-120	S211-120	S211-120
10	Vis, 5/16-18 x 3/4"	4	S7-51	S7-51	S7-51	S7-51	S7-51	S7-51	S7-51	S7-51
11	Farre d'accouplement	4	260402-200	260402-300	260402-300	260402-300	260402-400	260402-400	260402-500	260402-500
12	Pièce d'espacement	4	260401-2	260401-3	260401-3	260401-3	260401-4	260401-4	260401-5	260401-5
13	Assemblage de moyeu et manchon	3	600640	600640	600640	600640	600640	600640	600640	600640
15	Assemblage de manche loquant	1	280109	280109	280109	280109	280109	280109	280109	280109
20	Vis, 5/16-18 x 1/2"	8	S2-51	S2-51	S2-51	S2-51	S2-51	S2-51	S2-51	S2-51
21	Écrou, 5/16-18	8	300107	300107	300107	300107	300107	300107	300107	300107
22	Traverse	2	261501-2	261501-3	261501-3	261501-3	261501-4	261501-4	261501-5	261501-5
24	Vis, 1/4-20 x 5/8"	3	S2-42	S2-42	S2-42	S2-42	S2-42	S2-42	S2-42	S2-42
25	Moteur	1	260409	260409	260409	260450	260409	260409	260409	260409
26	Moteur à engrenages	1	260408	260408	260408	260408	260408	260408	260408	260408
27	Vis 5/16-18 x 5/8"	4	S2-52	S2-52	S2-52	S2-52	S2-52	S2-52	S2-52	S2-52
28	Support de moteur	1	260405	260405	260405	260405	260405	260405	260405	260405
29	Rondelle	4	300039	300039	300039	300039	300039	300039	300039	300039
30	Vis 5/16-18 x 5/8"	4	S2-52	S2-52	S2-52	S2-52	S2-52	S2-52	S2-52	S2-52
31	Écrou à embase 10-32	6	S79-3	S79-3	S79-3	S79-3	S79-3	S79-3	S79-3	S79-3
32	Engrenages de tambour	1	260407	260407	260407	260407	260407	260407	260407	260407
33	Entretoise	6	260410	260410	260410	260410	260410	260410	260410	260410
34	Écrou à embase 5/16-18	4	S85-7	S85-7	S85-7	S85-7	S85-7	S85-7	S85-7	S85-7
35	Tambour bridé	1	260406	260406	260406	260406	260406	260406	260406	260406
36	Vis 10-31 x 1 1/8"	6	S27-112	S27-112	S27-112	S27-112	S27-112	S27-112	S27-112	S27-112

## Série 3000 enrouleurs électriques

Article	DESCRIPTION	Quantité	EA33106 L12D	EA33106 M12D	EA33112 L10A	EA33112 L12D	EA33112 M10AX	EA33112 M12D	EA33112 M24D
1	Assemblage de pivot	1	602026	602026	602026	602026	602026	602026	602026
2	Vis, 5/16-12 x 5/8"	9	S317-31	S317-31	S317-31	S317-31	S317-31	S317-31	S317-31
3	Cadre Latéral	2	260403	260403	260403	260403	260403	260403	260403
5	Écrou, 5/16-18	8	S85-7	S85-7	S85-7	S85-7	S85-7	S85-7	S85-7
6	Tambour bridé	2	260399-3	260399-3	260399-3	260399-3	260399-3	260399-3	260399-3
7	Dispositif de retenue	4	300007	300007	300007	300007	300007	300007	300007
8	Assemblage d'entrée	1	600327-2	600327-2	600327-2	600327-2	600327-2	600327-2	600327-2
9	Anneau en "O"	1	S211-120	S211-120	S211-120	S211-120	S211-120	S211-120	S211-120
10	Vis, 5/16-18 x 3/4"	4	S7-51	S7-51	S7-51	S7-51	S7-51	S7-51	S7-51
11	Farre d'accouplement	4	260402-100	260402-100	260402-200	260402-200	260402-200	260402-200	260402-200
12	Pièce d'espacement	4	260401-1	260401-1	260401-2	260401-2	260401-2	260401-2	260401-2
13	Assemblage de moyeu et manchon	3	600640	600640	600640	600640	600640	600640	600640
15	Assemblage de manche loquant	1	280109	280109	280109	280109	280109	280109	280109
20	Vis, 5/16-18 x 1/2"	8	S2-51	S2-51	S2-51	S2-51	S2-51	S2-51	S2-51
21	Écrou, 5/16-18	8	300107	300107	300107	300107	300107	300107	300107
22	Traverse	2	261501-1	261501-1	261501-2	261501-2	261501-2	261501-2	261501-2
24	Vis, 1/4-20 x 5/8"	3	S2-42	S2-42	S2-42	S2-42	S2-42	S2-42	S2-42
25	Moteur	1	260409	260409	260430	260409	260430	260409	260450
26	Moteur à engrenages	1	260408	260408	260434	260408	260434	260408	260408
27	Vis 5/16-18 x 5/8"	4	S2-52	S2-52	S2-52	S2-52	S2-51	S2-52	S2-52
28	Support de moteur	1	260405	260405	260456	260405	260456	260405	260405
29	Rondelle	4	300039	300039	300039	300039	300039	300039	300039
30	Vis 5/16-18 x 5/8"	4	S2-52	S2-52	S2-52	S2-52	S2-51	S2-52	S2-52
31	Écrou à embase 10-32	6	S79-3	S79-3	S79-3	S79-3	S79-3	S79-3	S79-3
32	Engrenages de tambour	1	260407	260407	260407	260407	260407	260407	260407
33	Entretoise	6	260410	260410	260410	260410	260410	260410	260410
34	Écrou à embase 5/16-18	4	S85-7	S85-7	S85-7	S85-7	S85-7	S85-7	S85-7
35	Tambour bridé	1	260406	260406	260406	260406	260406	260406	260406
36	Vis 10-31 x 1 1/8"	6	S27-112	S27-112	S27-112	S27-112	S27-112	S27-112	S27-112

Article	DESCRIPTION	Quantité	EA33118 L10A	EA33118 L12D	EA33118 M10AX	EA33118 M12D	EA33122 L12D	EA33128 L12D	EA33128 M12D
1	Assemblage de pivot	1	602026	602026	602026	602026	602026	602026	602026
2	Vis, 5/16-12 x 5/8"	9	S317-31	S317-31	S317-31	S317-31	S317-31	S317-31	S317-31
3	Cadre Latéral	2	260403	260403	260403	260403	260403	260403	260403
5	Écrou, 5/16-18	8	S85-7	S85-7	S85-7	S85-7	S85-7	S85-7	S85-7
6	Tambour bridé	2	260399-3	260399-3	260399-3	260399-3	260399-3	260399-3	260399-3
7	Dispositif de retenue	4	300007	300007	300007	300007	300007	300007	300007
8	Assemblage d'entrée	1	600327-2	600327-2	600327-2	600327-2	600327-2	600327-2	600327-2
9	Anneau en "O"	1	S211-120	S211-120	S211-120	S211-120	S211-120	S211-120	S211-120
10	Vis, 5/16-18 x 3/4"	4	S7-51	S7-51	S7-51	S7-51	S7-51	S7-51	S7-51
11	Farre d'accouplement	4	260402-300	260402-300	260402-300	260402-300	260402-400	260402-500	260402-500
12	Pièce d'espacement	4	260401-3	260401-3	260401-3	260401-3	260401-4	260401-5	260401-5
13	Assemblage de moyeu et manchon	3	600640	600640	600640	600640	600640	600640	600640
15	Assemblage de manche loquant	1	280109	280109	280109	280109	280109	280109	280109
20	Vis, 5/16-18 x 1/2"	8	S2-51	S2-51	S2-51	S2-51	S2-51	S2-51	S2-51
21	Écrou, 5/16-18	8	300107	300107	300107	300107	300107	300107	300107
22	Traverse	2	261501-3	261501-3	261501-3	261501-3	261501-4	261501-5	261501-5
24	Vis, 1/4-20 x 5/8"	3	S2-42	S2-42	S2-42	S2-42	S2-42	S2-42	S2-42
25	Moteur	1	260430	260409	260430	260409	260409	260409	260409
26	Moteur à engrenages	1	260434	260408	260434	260408	260408	260408	260408
27	Vis 5/16-18 x 5/8"	4	S2-52	S2-52	S2-51	S2-52	S2-52	S2-52	S2-52
28	Support de moteur	1	260456	260405	260456	260405	260405	260405	260405
29	Rondelle	4	300039	300039	300039	300039	300039	300039	300039
30	Vis 5/16-18 x 5/8"	4	S2-52	S2-52	S2-51	S2-52	S2-52	S2-52	S2-52
31	Écrou à embase 10-32	6	S79-3	S79-3	S79-3	S79-3	S79-3	S79-3	S79-3
32	Engrenages de tambour	1	260407	260407	260407	260407	260407	260407	260407
33	Entretoise	6	260410	260410	260410	260410	260410	260410	260410
34	Écrou à embase 5/16-18	4	S85-7	S85-7	S85-7	S85-7	S85-7	S85-7	S85-7
35	Tambour bridé	1	260406	260406	260406	260406	260406	260406	260406
36	Vis 10-31 x 1 1/8"	6	S27-112	S27-112	S27-112	S27-112	S27-112	S27-112	S27-112