



ABANAKI
CORPORATION

17387 Munn Road
Chagrin Falls, OH 44023
Phone: (440) 543-7400
Fax: (440) 543-7404
1-800-358-SKIM (7546)
www.abanaki.com

ODM-100 Oil Concentrator®

Installation Instructions

The Abanaki ODM-100 Oil Concentrator® offers complete oil/water separation for reuse or disposal of either liquid. Mounted at the discharge end of the oil skimmer, the Oil Concentrator receives the skimmed liquid directly from the skimmer. Based on the principle of gravity separation, water is decanted from the bottom, the lighter weight oil is removed from the top.

If you are mounting the ODM-100 Oil Concentrator on a Mighty-Mini, the Adapter Bracket is turned upside down as shown in figure 1. If you are mounting the ODM-100 Oil Concentrator on a Tote-It, the Adapter Bracket is upright as shown in figure 2.

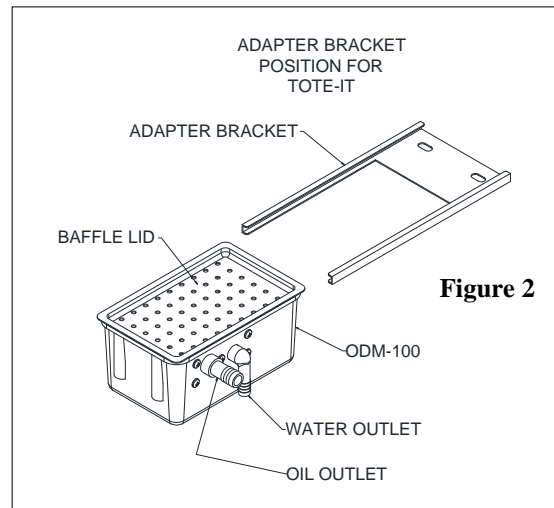
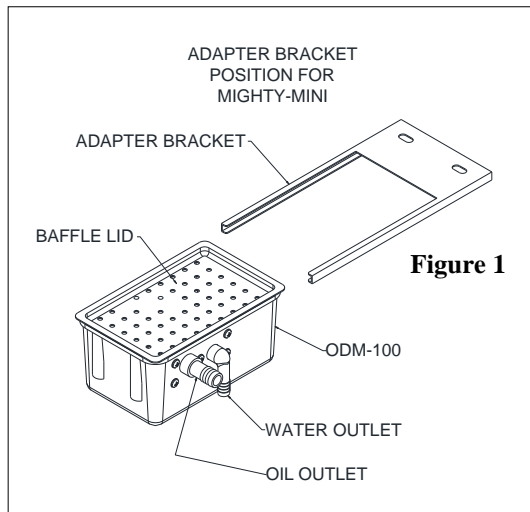

Step 1. MOUNTING THE ODM-100 OIL CONCENTRATOR®.

Mighty-Mini Oil Skimmers:

1. If mounting the Mighty-Mini® directly on the lip of a tank.
 - A) Drill (2) 7/16" dia. holes on the lip of the tank, in the location desired, to match the hole pattern on the bottom of the skimmer. (See Fig. 3)
 - B) After drilling thru holes, place the ODM-100 Adapter Bracket between the skimmer and mounting surface and fasten securely. **Note:** Make sure the adapter bracket is level. Unit will not operate properly unless it is level.
2. If mounting the Mighty-Mini® on a flanged tank using the multi-mount bracket. (See Fig. 4)
 - A) Place the Bolt Plate on the flange of the tank in the location desired.
 - B) Place the Universal Mount on top of the Bolt Plate as shown in figure 4.
 - C) Place the ODM-100 Adapter Bracket on top of the Universal Mount and set the skimmer on top.
 - D) Fasten the skimmer down on the Bolt Plate lugs.
 - E) Using the Tube Clamp, secure Universal Mount to the flange on the tank.
 - F) Make sure the adapter bracket is level. Unit will not operate properly unless it is level.
3. If mounting the Mighty-Mini® on a vertical wall of a tank using the multi-mount bracket. (See Fig. 5)
 - A) Place the ODM-100 Adapter Bracket between the skimmer and the Universal Mount.
 - B) Place the Bolt Plate from underneath and fasten all together.
 - C) Place the Universal Mount on top edge of the tank wall and clamp with Tube Clamp.
 - D) Make sure the adapter bracket is level. Unit will not operate properly unless it is level.

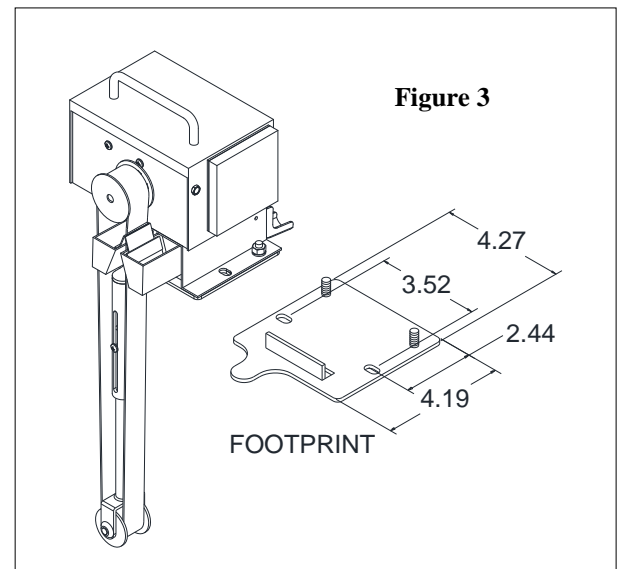



ABANAKI
CORPORATION

17387 Munn Road
Chagrin Falls, OH 44023
Phone: (440) 543-7400
Fax: (440) 543-7404
1-800-358-SKIM (7546)
www.abanaki.com

ODM-100 Oil Concentrator®

Installation Instructions

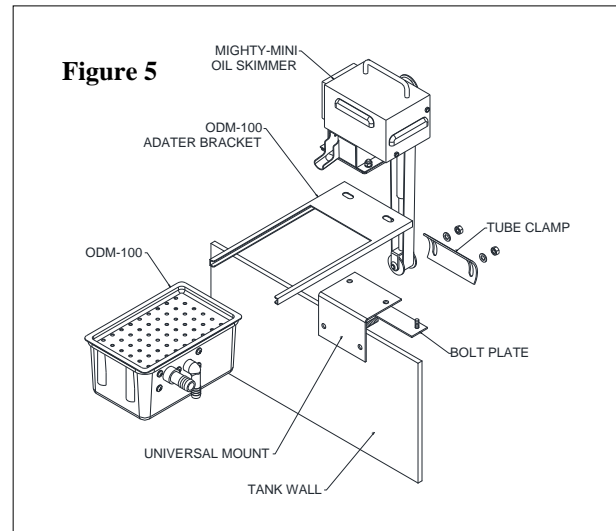
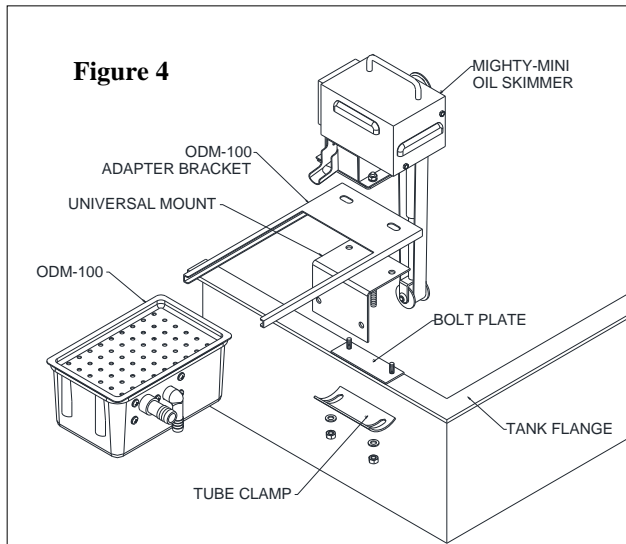

Tote-It® Oil Skimmer: (See Fig. 6)

1. Place the ODM-100 Adapter Bracket underneath the motor inside the Tote-It® base.
2. Line-up the holes in the adapter bracket with those in the base of the skimmer and fasten.
3. Make sure the adapter bracket is level. Unit will not operate properly unless it is level.

Step 2.

With the baffle lid on the decanter, slide the ODM-100 into the adapter bracket. (See Figures 1 or 2)

Step 3. Connecting Hoses

Mighty-Mini® Oil Skimmer:

Connect a 3/4" I.D. hose to the oil outlet running the discharge end to the waste oil container. Connect a 1/2" I.D. hose to the water outlet running the discharge end back into the skim tank.¹

Tote-It® Oil Skimmer:

Attach a 10" lg. hose onto a 1-1/4" adapter with clamp and screw adapter into fitting underneath motor. Hose will discharge onto the baffle lid.² Connect hoses onto decanter the same as for the Mighty-Mini® above.

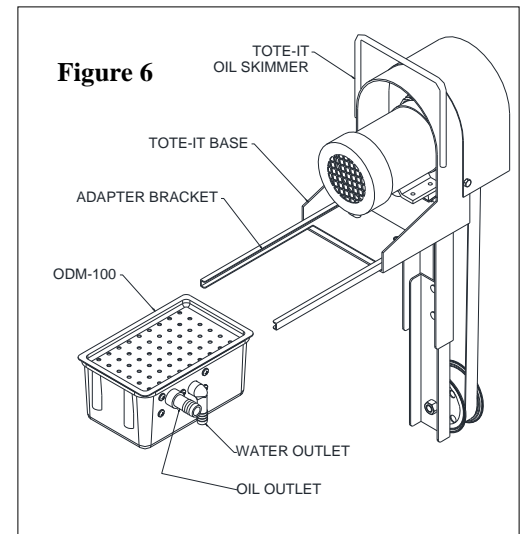

Step 4. PRIMING THE ODM-100

IMPORTANT: Prime the ODM-100 by filling to the outlet ports on the manifold with water or coolant. **THE UNIT WILL NOT OPERATE UNLESS IT IS PRIMED.** Note: The ODM-100 will maintain a thick oil layer before starting to discharge oil.

NOTE: The ODM-100 manifold has been pre-adjusted at the factory. No adjustments are necessary.

PERIODIC MAINTENANCE:

- The baffle lid should be checked and cleaned of debris as needed.
- If the incoming oil contains fine particles, empty and clean the ODM-100 when a layer of sludge has built up on the bottom of the unit.

¹ Optional hose kit for the ODM-100 & Mighty-Mini is available from Abanaki – Part #PDM100-10.

² Optional hose kit for the ODM-100 & Tote-It is available from Abanaki – Part #PDM100-20.