

Mighty Mini[®] SST

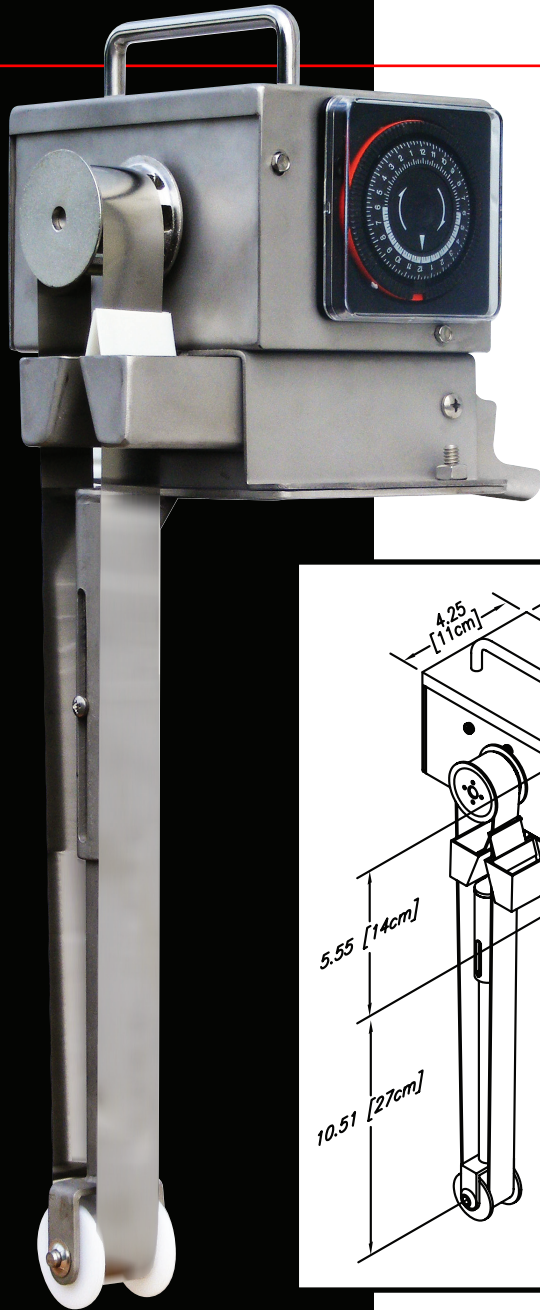

The stainless steel Mighty Mini is a compact belt skimmer designed for parts washers and machine tool coolant sumps. With its large discharge trough and small operating space, the Mighty Mini fits almost anywhere. The stainless steel construction resists rust and corrosion in harsh environments. It is lightweight and requires minimal assembly. With its durable stainless steel construction, it is built to give long lasting performance. The removable trough makes cleanup fast and easy.

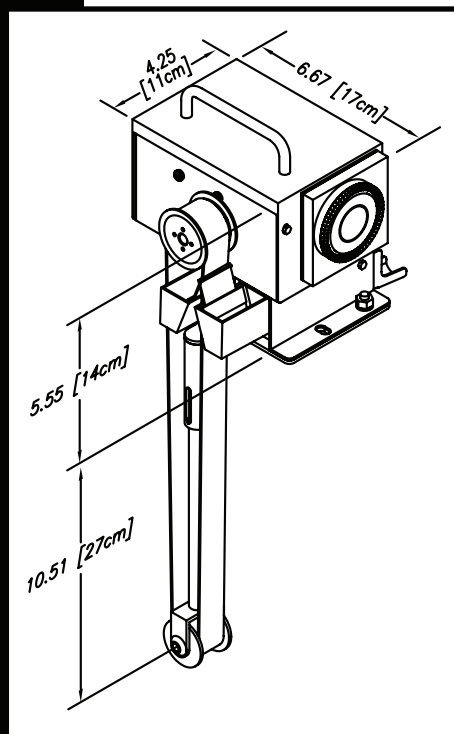

The Mighty Mini Advantages

- One year limited warranty, 30 day money back guarantee
- Stainless steel construction
- Fan cooled gear motor
- Spring loaded stabilizer bar
- Available in lengths from 6 to 24 inches
- Available in 1" and 2" belt widths
- Integrated 24-Hour timer w/15 minute increment settings for automatic operation.



ABANAKI[®] OIL SKIMMERS

USA: 17387 Munn Road • Chagrin Falls, Ohio 44023
800-358-SKIM (7546) • (440) 543-7400 • FAX: (440) 543-7404

UK: Unit 13 • Avondale Business Centre • Woodland Way • Bristol BS15 1AW
0117 9616679 • FAX: 0117 9616687

www.abanaki.com

Mighty Mini® SST

Optional Coolant Saving Decanter

With any skimmer, it is possible for coolant to be picked up when little or no oil is present. The ODM100 decanter is specifically designed for use with the Mighty Mini to separate and return nearly all coolant from the skimmed oil back to the tank. This saves money on both coolant and disposal costs.



Belt Options:

- Steel:** The standard material – can be used almost anywhere. Withstands temperatures up to 212°F. pH range of 2–13 at ambient temperatures.
- Elastomer:** Recommended for coolant applications because of its resistance to rust inhibitors and chips. Withstands temperatures up to 120°F and pHs from 2–13 at ambient temperatures.
- Poly:** Recommended for heavy oils and greases. Withstands temperatures up to 140°F and pHs from 2–13 at ambient temperatures.
- XP Poly:** Used in high temperature/high pH applications as in parts washers and plating. Withstands temperatures up to 180°F and pHs from 4–13 at higher temperatures.
- Fuzzy:** Specially designed material for removal of light oils (ie. gasoline, diesel) Withstands temperatures up to 140°F and pHs from 5–10 at ambient temperatures.

Other Oil Skimming Products From Abanaki

Model 4®

For Most Applications
Single 8-inch wide belt (20.3 cm)
Any length belt
Capacity: 40 GPH (151.4 LPH)

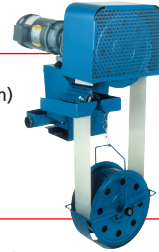

Model MB®

For High Volume
Two to five 8-inch belts (20.3 cm)
Any length belts
Capacity: to 200 GPH (757.1 LPH)



Tote-It® Portable

Portable for Moderate Capacity Applications
Single belt: 2-inch or 4-inch (5.1 or 10.2 cm)
Belt length: 1'-6" to 5'-0" (45.2 to 152.4 cm)
Capacity: 6 GPH - 2" belt (15.1 LPH - 5.1 cm belt)
12 GPH - 4" belt (22.7 LPH - 10.2 cm belt)

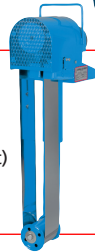

Disk Skimmer

Coolant Applications
12", 18" or 24" disks
Capacity: 1GPH

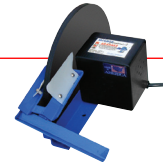

TubeTastic™ Tube Skimmer

Coolant Applications
8", 12", 18", 24", or 30" tubes
Capacity: 1.5GPH

