

A B A N A K I

MIGHTY DISK™ OIL SKIMMER

Model SDC-12

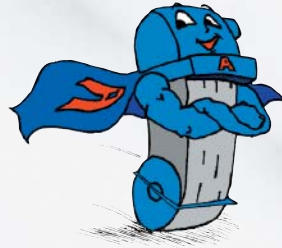

Model SDS-12

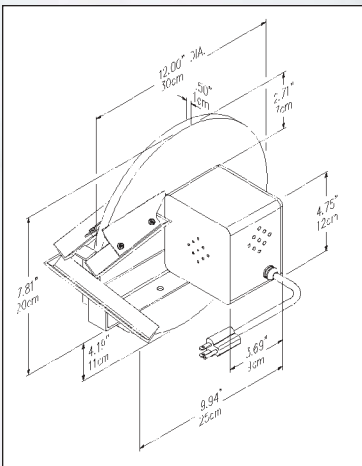
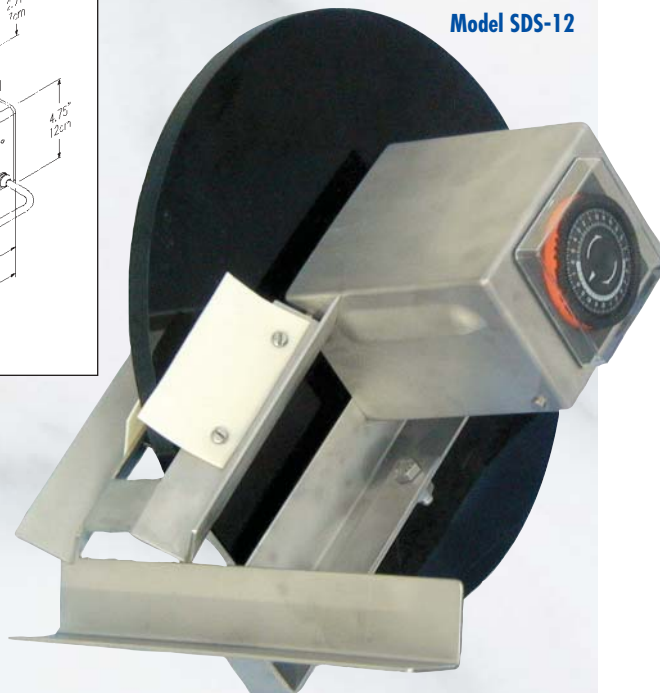

The inexpensive way to remove unwanted tramp oils from coolants and parts washers, but with all the quality that you expect from Abanaki!

Effective. Removes up to 1½ gallons of oil or more of medium weight oil per hour.

Compact. Use it almost anywhere a flat surface is available for mounting.

Portable. Weighs less than 10 pounds, installs in no time, and runs on 110v power.

Complete. Put it to work right out of the box, or add the optional coolant saving decanter for a more efficient skimming system.

Standard Features

- Available in 12" and 18" diameters
- 110v fan cooled motor
- High temperature disk material
- Quality construction

Optional Features

- 24 hour timer
- Coolant saving decanter

Stainless steel disk skimmers for harsh chemical environments!

Introducing a disk skimmer constructed of stainless steel for those applications where carbon steel may fail. Perfect for parts washers or plating tanks!



ABANAKI
CORPORATION
OIL SKIMMER DIVISION

17387 Munn Road • Chagrin Falls, Ohio 44023
Ph: (440) 543-7400 • FAX: (440) 543-7404

E-Mail: info@abanaki.com
800-358-SKIM (7546)
www.abanaki.com