

# INSTALLATION ADJUSTMENT SERVICE

## THERMOSTATIC STEAM AND WATER MIXING VALVE

### TYPE TMS-25, 50, 80, 125, 150

IMPORTANT! Provide valve serial number (stamped on cover of valve) when ordering parts!!

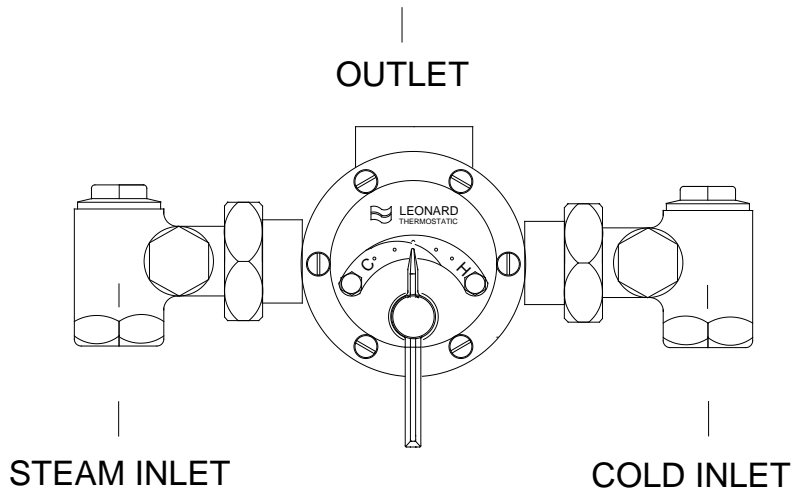

## INSTALLATION

1. Valve should be installed at a location where it can easily be cleaned, adjusted or repaired.
2. The inlets are clearly marked on the valve body casting. Connect the Steam into the inlet marked "H" cold water into the inlet marked "C".
3. Use pipe cement sparingly. Supply pipes should be flushed before the valve is connected. Flush outlet pipe and valve as soon as it is connected.
4. Union Angle stops furnished must be installed on both supply lines as shown above.
5. A shutoff valve must be installed on the outlet pipe. Type TMS valves do not have a built in shutoff.
6. IMPORTANT! Not for use with steam and water pressures above 80 PSI (5.5 bar). The prevailing steam (or hot water) pressure must be slightly lower than the cold water pressure.
7. Not for use with unequal pressures. Install pressure reducing valves where unequal pressure conditions exist.
8. Maximum recommended operating temperature of 200°F (93°C). Note This maximum temperature is for valve only, see hose specification for rating temperature.
9. Provide a steam trap prior to the blender to eliminate water hammer.
10. When used for high temperature wash down (140°F to 180°C) operators should wear protective gloves, boots and clothing, and they should be given safety instructions in the proper use of high temperature hot water.

**CAUTION:** These valves may pass live steam under certain circumstances. A limit stop is simply a mechanical setting to prevent excessive handle rotation. When turned to full HOT valve may deliver water in excess of safe temperatures, therefore the limit stop **MUST BE RESET BY THE INSTALLER**. Protective clothing must be worn at all times.

1360 Elmwood Avenue, Cranston, RI 02910 USA

Phone: 401.461.1200 Fax: 401.941.5310

Email: [info@leonardvalve.com](mailto:info@leonardvalve.com)

Web Site: <http://www.leonardvalve.com>

# ADJUSTMENT AND SERVICE

Leonard Type TMS Thermostatic Steam and Water Mixing Valves are simple in design and may be easily cleaned, adjusted and repaired. If the installation is accessible, servicing may be completed without disconnecting the valve.

**NOTE:** Thermostatic Steam and Water Mixing Valves are **REGULATING** mechanisms, which must be regularly maintained to provide best performance. Frequency of cleaning depends on quality of local water conditions and usage. (See Maintenance Guide and Record MGR-1000).

## TO RESET ADJUSTABLE HIGH TEMPERATURE LIMIT STOP:

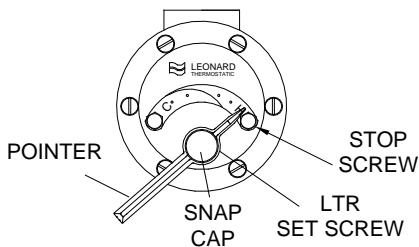

1. Loosen LTR set screw.
2. Remove SNAP CAP, SCREW & WASHER. Remove POINTER.
3. Temporarily place POINTER on the spline rod. turn RIGHT for warmer temperature, turn LEFT for cooler temperature. When valve is delivering warmest temperature desired, remove the pointer.
4. Replace POINTER on the spline rod so that its RIGHT edge is resting against the STOP SCREW located on the RIGHT SIDE OF THE COVER.
5. The new maximum temperature has now been set. Test this temperature by holding a thermometer under the flow of water to be certain it is as desired.

## !! WARNING !!

**WARNING!** This Thermostatic Mixing Valve has an adjustable high temperature limit stop, which must be checked. If temperature is too high, the installer **MUST RESET** this stop immediately. Always check the temperature of the mixed water when the lever handle is turned to full **HOT**. Excessively hot water is **DANGEROUS AND MAY CAUSE SCALDING!**

**THESE VALVES MAY PASS LIVE STEAM UNDER CERTAIN CIRCUMSTANCES.**

The high temperature limit stop is factory set at approximately 140°F (60°C) with incoming steam and cold water supply pressures of 50PSI (3.4BAR). If the incoming steam or water supplies are different from those noted above, the valve when turned to full hot may deliver water in excess of 140°F and the high temperature limit stop **MUST BE RESET BY THE INSTALLER.**

**IMPORTANT! Not for use with steam and water pressures above 80 PSI (5.5 bar). The prevailing steam (or hot water) pressure must be slightly lower than the cold water pressure.**

## TROUBLESHOOTING INSTRUCTIONS

		TMS-25	TMS-50/80	TMS-125/150
PACKING & GASKETS	1. Leak at pointer rod. 2. Leak between valve cover and base.	1/50ST	1/50ST	1/125ST
PORT SLEEVE ASSEMBLY	3. Valve delivers either all hot or all cold water, or will not mix consistently.	TGM-1/30ST or R/30ST	TGM-1/50ST or R/50ST	TGM-1/125ST or R/125ST
THERMOSTAT GROUP	4. After cleaning or replacing port sleeve assembly, valve will not hold temperature.	TGM-2/50 or R/30ST	TGM-2/50 or R/50ST	TGM-2/125 or R/125ST
CHECKSTOPS	5. Steam bypass into cold supply. 6. Cold water bypass into steam supply.	KIT 2/50 ST	KIT 2/50 ST	KIT 2/50 ST

**SEE PAGE 4 FOR COMPLETE PARTS BREAKDOWN, PARTS KITS**

**REMEMBER! THIS IS A CONTROL DEVICE WHICH MUST BE CLEANED AND MAINTAINED ON A REGULAR BASIS. (SEE MAINTENANCE GUIDE AND RECORD, MGR-1000).**

# INSTRUCTIONS FOR DISMANTLING VALVE

1. Shut off Steam and Cold supplies to valve.
2. Loosen LTR set screw.
3. Remove SNAP CAP, SCREW and WASHER, POINTER and FRICTION SPRING. (FIGURE #1).

WHEN RE-ASSEMBLING VALVE, insert new Flange Packing in base; replace COVER, tightening COVER SCREWS in rotation; put FRICTION SPRING in place; then replace POINTER and POINTER ROD SCREW, WASHER and CAP.

After installing new parts, it will be necessary to reset Pointer to obtain correct temperature range from Cold to Hot. See page 2 instructions "TO RESET ADJUSTABLE HIGH TEMPERATURE LIMIT STOP."

## TO CLEAN PORT SLEEVE ASSEMBLY

Failure to properly blend the water may be caused by a sticking condition in the PORT SLEEVE ASSEMBLY. The THIMBLE should slide freely on the PORT SLEEVE.

1. If a deposit of lime or sediment prevents free movement, use a nail set or other tapered tool to unscrew the CHECK NUT as far as it will go, then screw the PORT SLEEVE NUT into the base. This will release the PORT SLEEVE and THIMBLE so they can be lifted out. (Figure #2).
2. Clean with a NON-CORROSIVE CLEANING AGENT AND SOFT CLOTH - DO NOT USE ABRASIVES - then wash parts thoroughly, wipe with a dry cloth and re-assemble. The PORT SLEEVE should be assembled with the SHOULDER to the LEFT. Tighten PORT SLEEVE NUT against end of PORT SLEEVE but be careful not to cramp sleeve in place. Tighten CHECK NUT.
3. When replacing front be sure DRIVING BALL is inserted in Ball Socket as shown in Figure #1.

## TO REPLACE POINTER ROD WITH GEAR

1. Loosen LTR set screw. Remove POINTER ROD SNAP CAP, SCREW, WASHER, POINTER, and FRICTION SPRING. (FIGURE #1)
2. Remove COVER with parts attached, from the front of valve.
3. Remove COIL SLEEVE STUD and take off THERMOSTAT GROUP.
4. Replace POINTER ROD with GEAR and re-assemble.

## TO REPLACE (OR CLEAN) THERMOSTAT GROUP

Follow instruction for replacing POINTER ROD with GEAR above. If a deposit has collected on the Thermostatic Coil, clean it off with a brush in a non-corrosive grit-free cleaning solution.

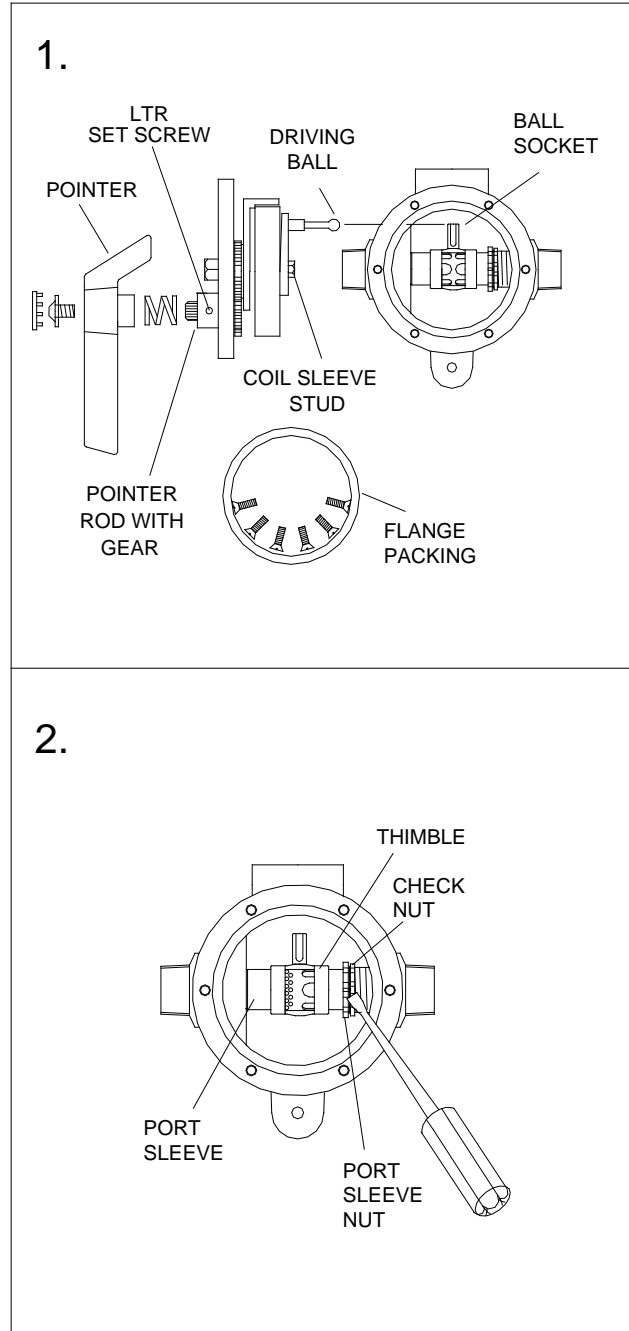

**REMEMBER! THIS IS A CONTROL DEVICE WHICH MUST BE CLEANED AND MAINTAINED ON A REGULAR BASIS. (SEE MAINTENANCE GUIDE AND RECORD, MGR-1000).**

# TMS-25/50/80 VALVE PARTS

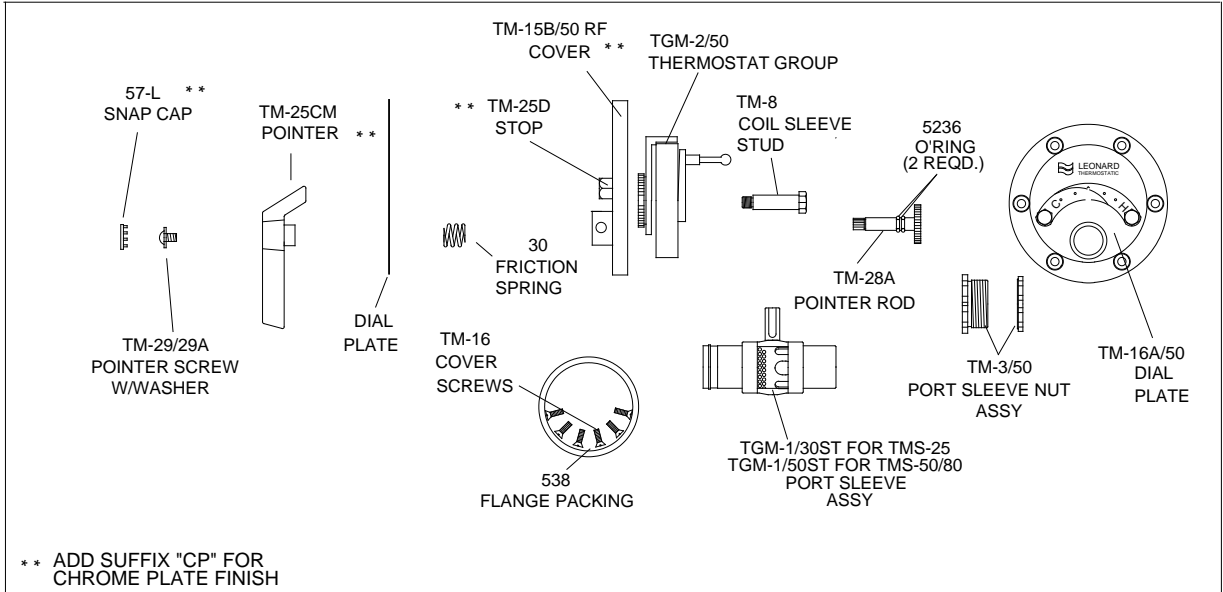

## CHECKSTOP PARTS

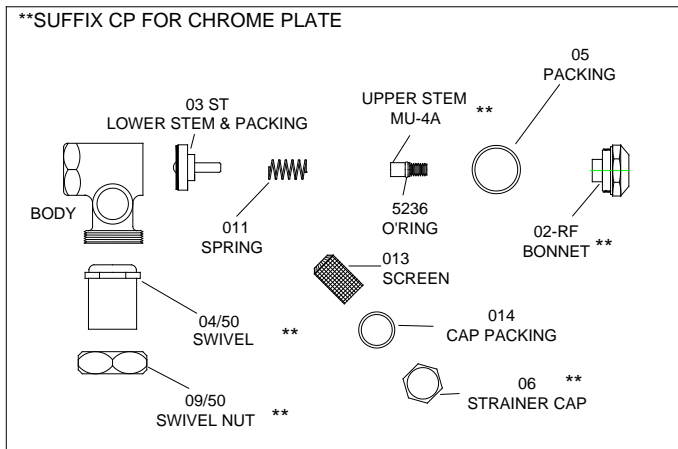

## LOCK TYPE POINTER

TMS valves are furnished with lockable pointers.

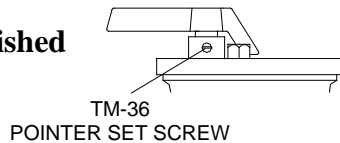

**REMEMBER!** THIS IS A CONTROL DEVICE WHICH MUST BE CLEANED AND MAINTAINED ON A REGULAR BASIS (SEE MAINTENANCE GUIDE AND RECORD (MGR-1000).

**NOTE:** AFTER INSTALLING NEW PARTS IT WILL BE NECESSARY TO RESET THE ADJUSTABLE HIGH TEMPERATURE LIMIT STOP (SEE PAGE 2).

## REPAIR KITS

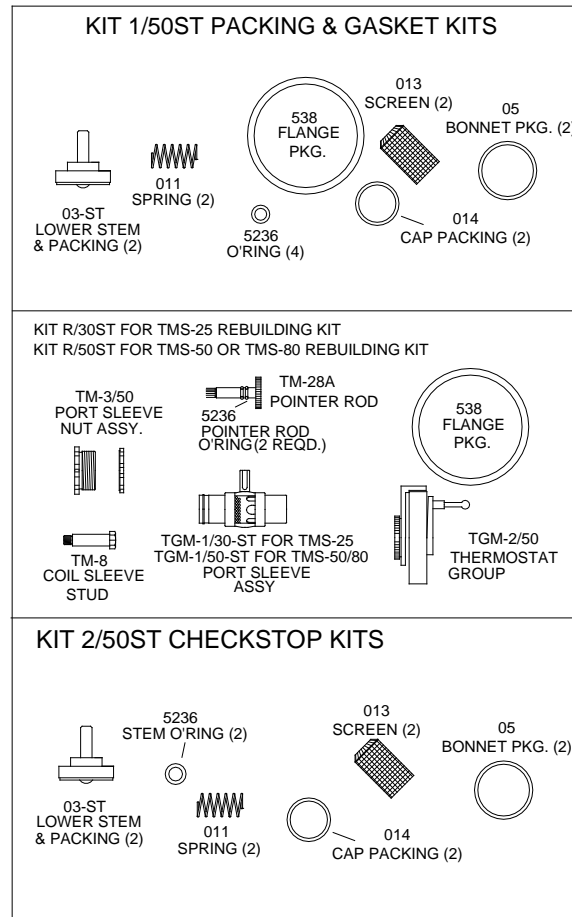

# TMS-125/150 VALVE PARTS

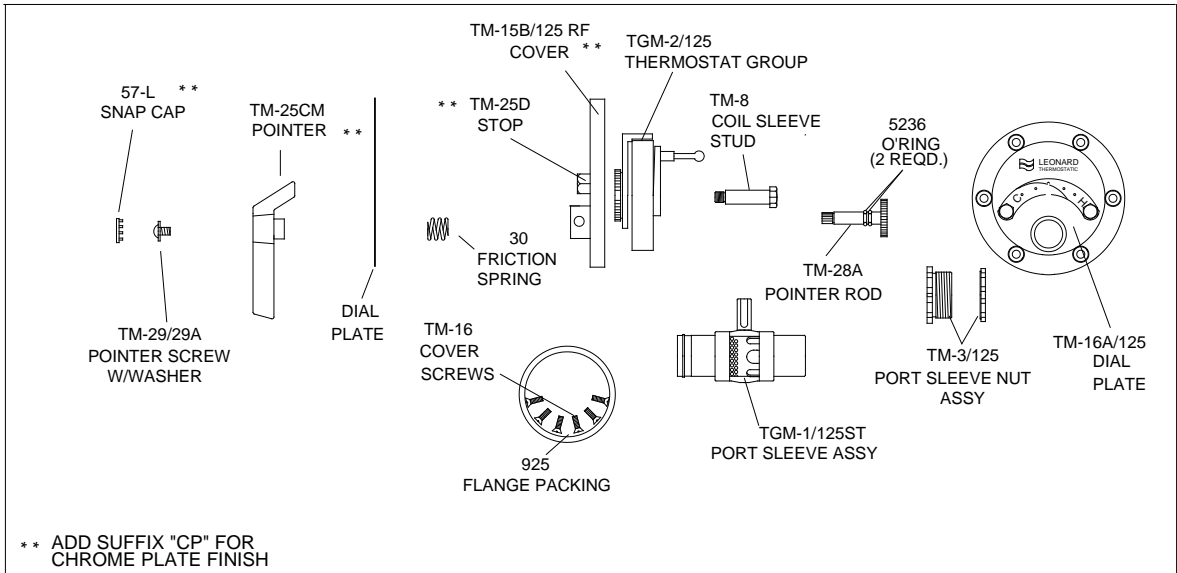

## CHECKSTOP PARTS

## REPAIR KITS

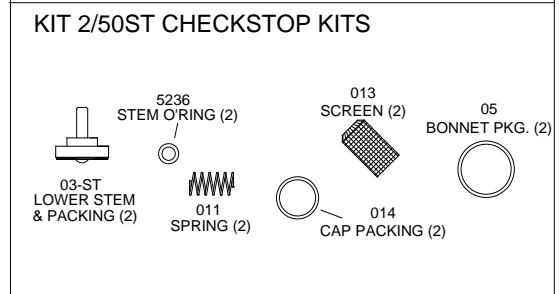
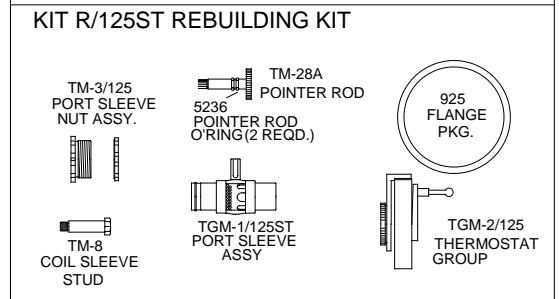
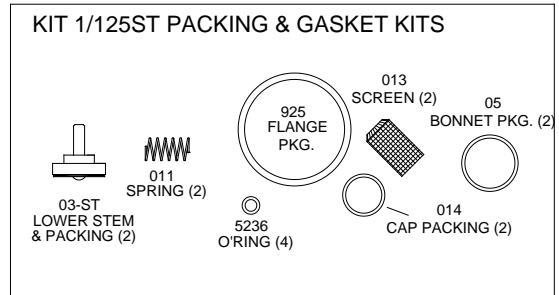
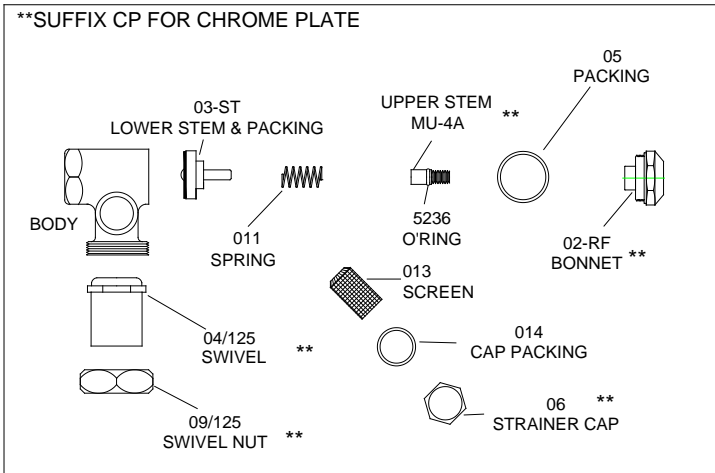

## LOCK TYPE POINTER

TMS valves are furnished with lockable pointers.

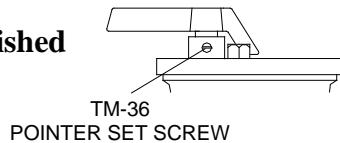

**REMEMBER!** THIS IS A CONTROL DEVICE WHICH MUST BE CLEANED AND MAINTAINED ON A REGULAR BASIS (SEE MAINTENANCE GUIDE AND RECORD (MGR-1000).

**NOTE:** AFTER INSTALLING NEW PARTS IT WILL BE NECESSARY TO RESET THE ADJUSTABLE HIGH TEMPERATURE LIMIT STOP (SEE PAGE 2).

# FLOW CAPACITIES

## TMS-25 (3/4" IN, 3/4" OUT)

### TEMPERATURE RISE

PSI BAR	20°F 11°C	30°F 16°C	40°F 22°C	50°F 27°C	60°F 33°C	70°F 38°C	80°F 44°C	
35 2.4	23.0 87.0	19.5 74.0	16.5 62.5	14.5 55.0	13.0 49.5	11.5 43.5	10.5 40.0	GPM l/min
45 3.1	27.5 104.0	24.0 91.0	20.0 76.0	18.0 68.0	16.0 60.5	14.0 53.0	13.0 49.5	GPM l/min
55 3.8	30.0 113.5	27.0 102.0	23.0 87.0	20.0 76.0	18.0 68.0	16.5 62.5	15.0 57.0	GPM l/min
65 4.5	33.5 127.0	29.0 110.0	25.0 94.5	22.5 85.0	20.0 76.0	17.5 66.0	16.0 60.5	GPM l/min

FLOW RATE (GPM)

## TMS-50 (3/4" IN, 1" OUT)

### TEMPERATURE RISE

PSI BAR	20°F 11°C	30°F 16°C	40°F 22°C	50°F 27°C	60°F 33°C	70°F 38°C	80°F 44°C	
35 2.4	25.0 94.5	22.0 83.5	18.0 69.0	15.5 60.0	14.0 53.5	12.5 48.0	12.0 45.5	GPM l/min
45 3.1	30.0 113.5	26.0 99.0	23.0 87.5	20.0 76.0	17.0 65.0	15.0 57.0	14.0 53.5	GPM l/min
55 3.8	33.0 126.0	30.0 113.5	26.0 99.0	22.5 84.0	20.0 76.0	18.0 69.0	16.5 63.0	GPM l/min
65 4.5	37.5 142.0	33.5 126.5	30.0 113.5	26.0 99.0	22.5 84.0	20.0 76.0	17.5 67.0	GPM l/min

FLOW RATE (GPM)

## TMS-80 (1" IN, 1 1/4" OUT)

### TEMPERATURE RISE

PSI BAR	20°F 11°C	30°F 16°C	40°F 22°C	50°F 27°C	60°F 33°C	70°F 38°C	80°F 44°C	
35 2.4	27.5 104.0	23.5 89.0	19.0 72.0	17.0 65.0	14.5 55.0	13.0 49.5	12.5 48.0	GPM l/min
45 3.1	32.5 123.0	29.0 110.0	25.0 94.5	21.0 78.5	18.0 68.0	16.5 62.5	15.0 57.0	GPM l/min
55 3.8	35.5 134.5	32.0 120.0	27.5 104.0	23.5 89.0	21.0 78.5	18.5 70.0	17.0 65.0	GPM l/min
65 4.5	40.0 151.5	35.5 134.5	32.0 121.0	27.5 104.0	23.5 89.0	21.0 78.5	18.0 68.0	GPM l/min

FLOW RATE (GPM)

### FLOW RATE AT 45 PSI

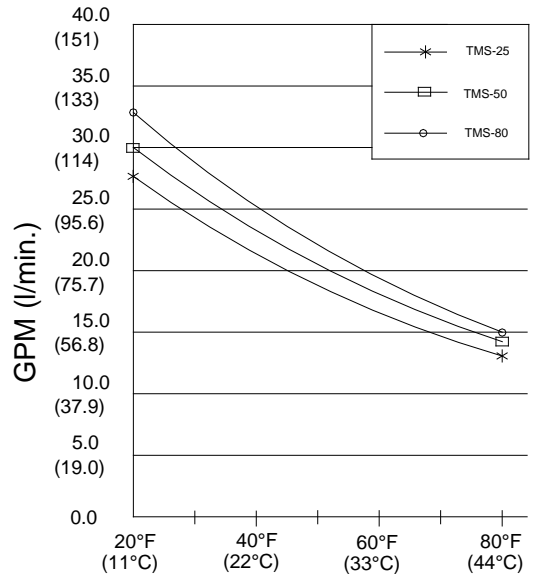

1360 Elmwood Avenue, Cranston, RI 02910 USA

Phone: 401.461.1200 Fax: 401.941.5310

Email: [info@leonardvalve.com](mailto:info@leonardvalve.com)

Web Site: <http://www.leonardvalve.com>

# FLOW CAPACITIES

## TMS-125 (1 1/4" IN, 1 1/4" OUT)

## TMS-150 (1 1/4" IN, 1 1/2" OUT)

### TEMPERATURE RISE

### TEMPERATURE RISE

PSI BAR	20°F 11°C	30°F 16°C	40°F 22°C	50°F 27°C	60°F 33°C	70°F 38°C	80°F 44°C	
35 2.4	46.0 175.0	39.0 147.0	33.5 126.5	30.0 113.5	27.0 103.0	24.0 91.0	21.5 81.0	GPM l/min
45 3.1	54.5 206.5	44.5 168.5	37.5 142.0	33.5 126.5	30.0 113.5	26.5 100.5	23.0 87.0	GPM l/min
55 3.8	67.0 254.0	52.0 197.0	43.0 162.5	37.5 142.0	33.5 126.5	28.5 108.0	26.0 98.5	GPM l/min
65 4.5	75.0 284.0	60.0 227.0	50.0 189.5	43.0 162.5	37.5 142.0	33.5 126.5	28.5 108.0	GPM l/min

FLOW RATE (GPM)

PSI BAR	20°F 11°C	30°F 16°C	40°F 22°C	50°F 27°C	60°F 33°C	70°F 38°C	80°F 44°C	
35 2.4	50.0 189.0	41.5 157.0	35.5 134.5	31.5 119.0	28.0 106.0	24.5 92.5	22.0 83.0	GPM l/min
45 3.1	60.0 227.0	48.0 181.5	40.0 151.5	35.5 134.5	31.0 117.5	27.0 102.0	23.5 89.0	GPM l/min
55 3.8	75.0 284.0	57.0 215.5	46.0 174.0	40.0 151.5	34.5 130.5	29.5 111.5	26.5 100.0	GPM l/min
65 4.5	84.5 320.0	66.0 250.0	54.0 204.5	45.5 172.0	39.0 147.5	34.5 130.5	29.0 110.0	GPM l/min

FLOW RATE (GPM)

FLOW RATE AT 45 PSI

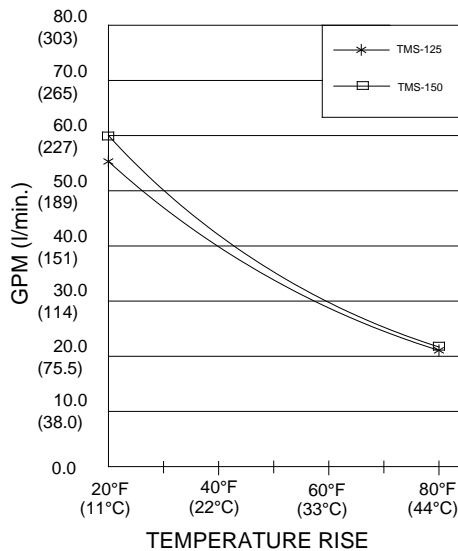

## LIMITED WARRANTY

Leonard Valve Company warrants the original purchaser that products manufactured by them (not by others) will be free from defects in materials and workmanship under normal conditions of use, when properly installed and maintained in accordance with Leonard Valve Company's instructions, for a period of one year from date of shipment. During this period the Leonard Valve Company will at its option repair or replace any product, or part thereof, which shall be returned, freight prepaid, to the Leonard factory and determined by Leonard to be defective in materials or workmanship. There are no warranties, express or implied, which extend beyond the description contained herein. There are no implied warranties of merchantability or of fitness for a particular purpose. In no event will Leonard be liable for labor or incidental or consequential damages. Any alteration or improper installation or use of the product will void this limited warranty.

1360 Elmwood Avenue, Cranston, RI 02910 USA

Phone: 401.461.1200 Fax: 401.941.5310

Email: [info@leonardvalve.com](mailto:info@leonardvalve.com)

Web Site: <http://www.leonardvalve.com>