

CUSTOMER SPECIFICATION DRAWING

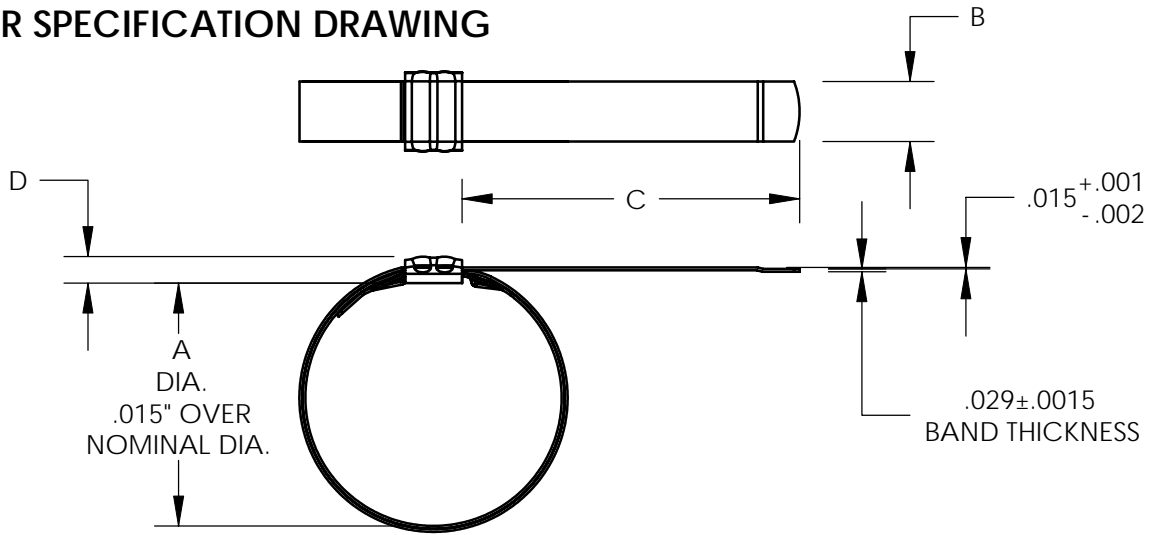

CLAMP PART NUMBER	MATERIAL 1		INSIDE DIA.	WIDTH	TAIL LENGTH	BUCKLE HEIGHT MAX.	QTY PER BOX	WEIGHT PER BOX [LBS.]
	BAND	BUCKLE						
GRS301	G.C.S.	201SS	.813	.375	3.44 ±.06	.192	24	.458
GRS302			1.375					.545
GRS306			1.750	.625	3.50 ±.12	.278		.791
GRS309			2.500					.828
GRS310			2.750	.750	3.63 ±.25	.293		.940
GRS312			3.500					1.005
GRS313			4.000				1.138	
GRS315			5.000				1.207	
GRS316			6.000	16	4.00 ±.38	1.278		
GRS318			7.000		4.40 ±.38	1.331		

NOTES:

1. BAND AND BUCKLE MATERIAL PER BAND-IT SPECIFICATION.

ABOVE SPECIFICATION CERTIFIED BY: _____ DATE: _____

TITLE: _____

UNLESS OTHERWISE NOTED:
DIMENSIONS ARE IN INCHES
AFTER FINISH

TOLERANCES:
X ±0.100
.XX ±0.020
.XXX ±0.005
.XXXX ±0.001
ANGLES ±0.5°

BAND-IT[®]

A unit of ~~IDEX~~ Corporation
P.O. Box 16307
Denver, Colorado U.S.A.

PROPRIETARY AND CONFIDENTIAL

THIS DRAWING WITH ALL CONTENTS IS PROPERTY OF BAND-IT-IDEX, INC. REPRODUCTION, DISCLOSURE OR MFG. OF MATTER SHOWN IS PROHIBITED WITHOUT WRITTEN PERMISSION. DO NOT SCALE DRAWING

TITLE:

**JUNIOR CLAMPS,
G.C.S., GRAINGER**

DWG. NO.

GRS200

REV -

SHEET 3 OF 3