

TE-6300P Series Wall Mount Temperature Sensors

Applications

North American Emissions Compliance

IMPORTANT: The TE-6300P Series Wall Mount Temperature Sensors are intended to provide an input to equipment under normal operating conditions. Where failure or malfunction of the TE-6300P sensor could lead to personal injury or property damage to the controlled equipment or other property, additional precautions must be designed into the control system. Incorporate and maintain other devices, such as supervisory or alarm systems or safety or limit controls, intended to warn of or protect against, failure or malfunction of the TE-6300P sensor.

Installation

IMPORTANT: Do not install the TE-6300P Series Wall Mount Temperature Sensor in ambient temperatures beyond the specified -50 to 122°F (-46 to 50°C) temperature range. Installing the temperature sensor in ambient temperatures beyond this range may damage the unit and void the warranty.

Dimensions

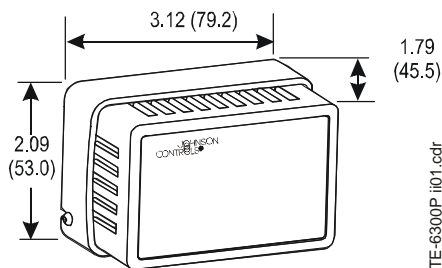

Figure 1: Sensor Dimensions, in. (mm)

Accessories

To mount the TE-6300P Series Wall Mount Sensor to an electrical box, order the TE-1800-9600 Mounting Hardware. To order a different cover for the wall mount sensor, refer to the *TE-6300 Series Temperature Sensors Product Bulletin (LIT-216320)*.

Mounting

Location Considerations

Consider the following mounting location guidelines:

- Avoid areas subject to excessive vibration, electrical noise, direct sunlight, or the effects of radiant heat.
- Keep electrical wiring as short as possible to minimize temperature error.

Mounting the Temperature Sensor

See Figure 2 and mount the temperature sensor as follows:

1. Loosen the socket-head screws on each side of the unit with a 0.62 in. hex key and remove the cover.
2. Drill the optional 5/16 in. (8 mm) hole only if using the drywall anchors provided; then insert the anchors into the holes.
3. Mount the base plate to the wall using the screws provided.
4. Wire the sensor to the controller wire with the wire nuts provided.
5. Reposition the cover and tighten the retention screws.
6. Install the optional faceplate (vertical mount only).

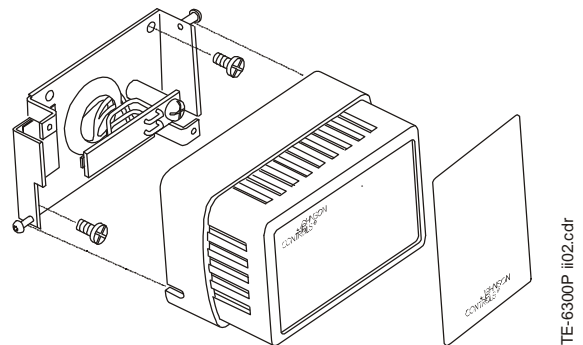

Figure 2: Installing the Wall Mount Sensor

Wiring

For 1k ohm nickel temperature sensors, wire resistance can cause approximately 1F° (0.56C°) of error for every 250 ft (76 m) run of 18 AWG wire, or every 100 ft (31 m) run of 22 AWG wire. For 1k ohm platinum temperature sensors, can cause approximately 1F° (0.56C°) of error for every 150 ft (46 m) run of 18 AWG wire, or every 50 ft (15 m) run of 22 AWG wire. To minimize error due to field wiring, limit the total resistance of all nickel temperature sensor wiring to 3 ohms, and all platinum temperature sensor wiring to 2 ohms.

The 2k ohm thermistor applications permit wiring to be quite long before wire resistance adds significantly to total resistance measured at the controller. As a general rule, a 150 ft (46 m) two-wire 18 AWG run contributes 2 ohms of error, or less than 1F° (0.56C°) error over the sensor operating temperature range.

See the appropriate controller documentation for recommended sensor wiring. See Table 1 for an explanation of the lead wiring color convention.

Table 1: Lead Wiring (22 AWG, 6 in.) Color Code

Sensor Type	Lead Color
1k ohm Nickel	White
1k ohm Platinum	White with blue stripe
2.2k ohm Thermistor	Red



CAUTION: Risk of Property Damage. Do not apply power to the system before checking all wiring connections. Short circuited or improperly connected wires may result in permanent damage to the equipment.

IMPORTANT: Make all wiring connections in accordance with local, national, and regional regulations.

Repair Information

For a replacement device, refer to the *TE-6300 Series Temperature Sensors Product Bulletin (LIT-216320)* and contact the nearest Johnson Controls® representative.

Technical Specifications

Product	TE-6300P Series	Wall Mount Temperature Sensors
Models	TE-6314P-1:	Thin-Film Nickel Temperature Sensor
	TE-6324P-1:	Thin-Film Platinum Temperature Sensor
	TE-6344P-1:	NTC Thermistor Temperature Sensor
Sensor Reference Resistance	Nickel:	1k ohms at 70°F (21°C)
	Platinum:	1k ohms at 32°F (0°C)
	Thermistor:	2,252 ohms at 77°F (25°C)
Sensor Accuracy	Nickel:	±0.34F° at 70°F (±0.19C° at 21°C)
	Platinum:	±0.73F° at 70°F (±0.41C° at 21°C), DIN Class B
	Thermistor:	±0.36F° (±0.2C°) in the range: 32 to 158°F (0 to 70°C)
Sensor Temperature Coefficient	Nickel:	Approximately 3 ohms/F° (5.4 ohms/C°)
	Platinum:	Approximately 2 ohms/F° (3.9 ohms/ C°)
	Thermistor:	Nonlinear, Negative Temperature Coefficient (NTC)
Materials	Base Plate:	Galvanized Steel
	Cover:	Rigid Thermoplastic, White
	Face Plate:	Brushed Aluminum
Operating Conditions	Temperature	-50 to 122°F (-46 to 50°C)

The performance specifications are nominal and conform to acceptable industry standards. For application at conditions beyond these specifications, consult the local Johnson Controls office. Johnson Controls, Inc. shall not be liable for damages resulting from misapplication or misuse of its products.



Building Efficiency
507 E. Michigan Street, Milwaukee, WI 53202

Metasys® and Johnson Controls® are registered trademarks of Johnson Controls, Inc. All other marks herein are the marks of their respective owners. © 2013 Johnson Controls, Inc.