

TE-6300A Series Adjustable Length Duct Probe Temperature Sensors

Installation Instructions

TE-6311A-1, TE-6351A-1,
TE-6341A-1, TE-6361A-1

Part No. 24-4034-247, Rev. B
Issued February 15, 2012
Supersedes April 6, 2010

Refer to the [QuickLIT Web site](#) for the most up-to-date version of this document.

Applications

IMPORTANT: The TE-6300A Series Adjustable Length Duct Probe Temperature Sensors are intended to provide an input to equipment under normal operating conditions. Where failure or malfunction of the sensor could lead to personal injury or property damage to the controlled equipment or other property, additional precautions must be designed into the control system. Incorporate and maintain other devices, such as supervisory or alarm systems or safety or limit controls, intended to warn of or protect against failure or malfunction of the sensor.

Installation

IMPORTANT: Do not install the TE-6300A Series Adjustable Length Duct Probe Temperature Sensor in ambient temperatures beyond the specified -50 to 140°F (-46 to 60°C) temperature range. Installing the temperature sensor in ambient temperatures beyond this range may damage the unit and void the warranty.

Dimensions

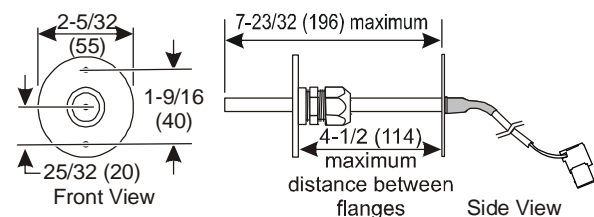

Figure 1: Sensor Dimensions, in. (mm)

Mounting

Location Considerations

Consider the following mounting location guidelines:

- Avoid areas subject to the effects of excessive vibration, electrical noise, direct sunlight, or radiant heat.
- Keep electrical wiring as short as possible to minimize temperature error.

Mounting the Sensor

See Figure 2, and mount the temperature sensor:

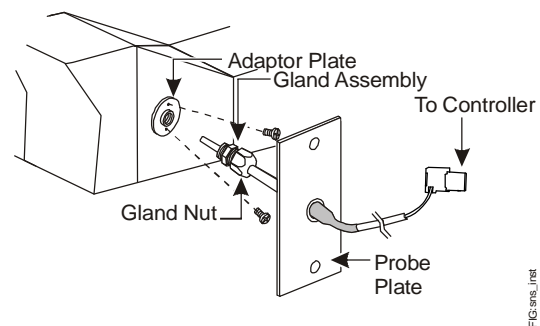

Figure 2: Installing the Duct Probe Sensor

1. Drill a 3/8 in. (10 mm) diameter hole at the desired mounting adapter location.
2. Assemble the adapter plate to the gland assembly, and mount to the duct using the two self-drilling screws provided.
3. Insert probe to the desired length, observing the limit specified in Figure 1.

IMPORTANT: Do not attach brackets or cables to the exposed sensor probe, or allow the probe to support additional weight. Support the sensor cable to protect the sensor from damage or malfunction.

4. Tighten the gland nut onto the probe two to three turns after the bushing inside the gland contacts the probe.
5. Plug the sensor into the controller.

Note: For applications not compatible with the terminal block connector, remove the terminal block connector and prepare the sensor leads as appropriate for the application.

Wiring

For 1k ohm nickel temperature sensors, wire resistance can cause approximately 1F° (0.56C°) of error for every 250 ft (76 m) run of 18 AWG (1.0 mm diameter) wire, or every 100 ft (30 m) run of 22 AWG (0.6 mm diameter) wire.

For 1k ohm platinum temperature sensors, wire resistance can cause about 1F° (0.56C°) of error for every 150 ft (46 m) run of 18 AWG (1.0 mm diameter) wire, or every 50 ft (15 m) run of 22 AWG (0.6 mm diameter) wire.

To minimize error due to field wiring, limit total resistance of all nickel temperature sensor wiring to 3 ohms and all platinum temperature sensor wiring to 2 ohms.

The 2.2k and 10k ohm thermistor applications permit wiring to be relatively long before wire resistance adds significantly to total resistance measured at the controller. As a general rule, a 150 ft (46 m) two-wire 18 AWG (1.0 mm diameter) run contributes 2 ohms of error, or less than 1F° (0.56C°) of error over the sensor operating temperature range.

Refer to the appropriate controller documentation for recommended sensor wiring.

Technical Specifications

TE-6300A Series Adjustable Length Duct Probe Temperature Sensors

Models	TE-6311A-1	Thin-Film Nickel Temperature Sensor
	TE-6351A-1	Thin-Film Platinum Temperature Sensor
	TE-6341A-1	2.2k ohm Thermistor Temperature Sensor
	TE-6361A-1	10k ohm Thermistor Temperature Sensor
Sensor Reference Resistance	1k ohm Nickel	1k ohms at 70°F (21°C)
	1k ohm Platinum	1k ohms at 32°F (0°C)
	2.2k ohm Thermistor	2,252 ohms at 77°F (25°C)
	10k ohm Thermistor	10.0k ohms at 77°F (25°C)
Sensor Accuracy	1k ohm Nickel	±0.34F° at 70°F (±0.19C° at 21°C)
	1k ohm Platinum	±0.35F° at 70°F (±0.19C° at 21°C), DIN Class A
	2.2k ohm Thermistor	±0.36F° (±0.2C°) in the range: 32 to 158°F (0 to 70°C)
	10k ohm Thermistor	±0.9F° (±0.5C°) in the range: 32 to 158°F (0 to 70°C)
Sensor Temperature Coefficient	1k ohm Nickel	Approximately 3 ohms/F° (5.4 ohms/C°)
	1k ohm Platinum	Approximately 2 ohms/F° (3.9 ohms/C°) 3,850 ppm/K
	2.2k ohm Thermistor	Nonlinear, Negative Temperature Coefficient (NTC)
	10k ohm Thermistor	Nonlinear NTC, Johnson Controls Type II
Electrical Connections		22 AWG x 10 ft (3 m) Long Plenum-Rated Cable, with 2-Position Plug Terminal Block for 1/4 in. (6.35 mm) Male Tab Terminals on 0.197 in. (5 mm) Centers
Materials	Probe	1/4 in. (6.4 mm) OD x 8 in. (203 mm) Long, Stainless Steel
	Mounting Adaptor Assembly	Plastic
Operating Conditions		-50 to 140°F (-46 to 60°C)

The performance specifications are nominal and conform to acceptable industry standards. For application at conditions beyond these specifications, consult the local Johnson Controls office. Johnson Controls, Inc. shall not be liable for damages resulting from misapplication or misuse of its products.



Building Efficiency
507 E. Michigan Street, Milwaukee, WI 53202

Metasys® and Johnson Controls® are registered trademarks of Johnson Controls, Inc. All other marks herein are the marks of their respective owners. © 2012 Johnson Controls, Inc.



CAUTION: Risk of Property Damage.
Do not apply power to the system before checking all wiring connections. Short circuited or improperly connected wires may result in permanent damage to the equipment.

IMPORTANT: Use copper conductors only. Make all wiring connections in accordance with local, national, and regional regulations. Do not exceed the TE-6300A Series Adjustable Length Duct Probe Temperature Sensor's electrical ratings.

Repair Information

If the TE-6300A Series Adjustable Length Duct Probe Temperature Sensor fails to operate within its specifications, replace the unit. For a replacement sensor, contact the nearest Johnson Controls® representative.