

SEN-600-1 and SEN-600-4 Remote Indoor Temperature Sensors

Installation Instructions

Part No. 24-9954-7, Rev. A
Issued August 30, 2013
Supersedes September 23, 2003

Refer to the [QuickLIT website](http://www.quicklit.com) for the most up-to-date version of this document.

Application

The SEN-600-1 and SEN-600-4 remote sensors are designed to allow remote indoor temperature sensing in applications with the T600 Series programmable and non-programmable thermostats and the TEC2000 Series Network Thermostats. The SEN-600-1 and SEN-600-4 contain an integral sensor and circuitry to interface with the T600 and TEC2000 Series Thermostats. Additionally, the SEN-600-4 has an override button and Light-Emitting Diode (LED) indicator to enable and indicate occupancy override from the remote sensor. Up to three remote sensors can be wired together for averaging.

Note: The SEN-600-4 remote indoor sensor is only intended for use with programmable T600 Series thermostats. Additionally, if the SEN-600-4 is used with a T600 non-programmable thermostat, the LED does not light up to indicate occupancy status.

Mounting

Prior to installing the sensor, install the T600 or TEC2000 Series Thermostat following the installation instructions provided with the thermostat.

Location Considerations

Locate the sensors as follows:

- on a partitioning interior wall, and approximately 5 ft (1.5 m) above the floor in a location of average temperature
- away from direct sunlight, radiant heat, outside walls, behind doors, air discharge grills, stairwells, or outside doors
- away from steam or water pipes, warm air stacks, unheated/uncooled areas, or sources of electrical interference

Installation

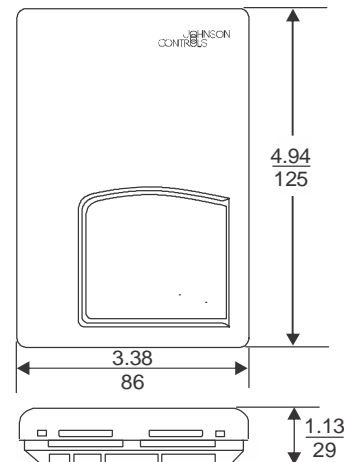

Figure 1: Sensor Dimensions, in./mm

To install the sensor:

1. Remove the security screw on the bottom of the sensor cover using a Phillips-head screwdriver. Open the thermostat by pulling on the bottom side of the sensor cover (see Figure 2).
2. Unlock the Printed Circuit Board (PCB) by carefully pressing the locking tabs to the right. Open the sensor's PCB to the left (see Figure 3).
3. Pull out approximately 6 in. (152 mm) of wires from the wall and insert the cable through the hole in the base.
4. Align the base on the wall, and using the base as a template, mark the location of the two mounting holes on the wall. Confirm the sensor base is installed with the proper side up.
5. Use the supplied anchors and screws for mounting on drywall or plaster. Drill two 3/16 in. (4.7 mm) holes at the marked locations and tap nylon anchors flush to wall surface (see Figure 4).
6. Position base on the wall, insert screws through mounting base, and fasten into wall anchors. Do not overtighten screws.
7. Swing the sensor's PCB back to the right to close. Gently press on the PCB to secure the locking tab.

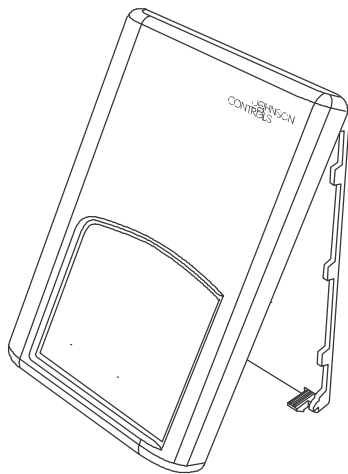

Figure 2: Removing the Sensor Cover

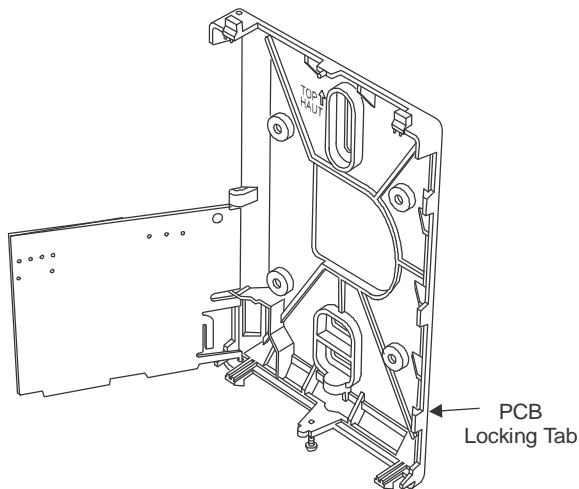

Figure 3: Opening the Sensor PCB

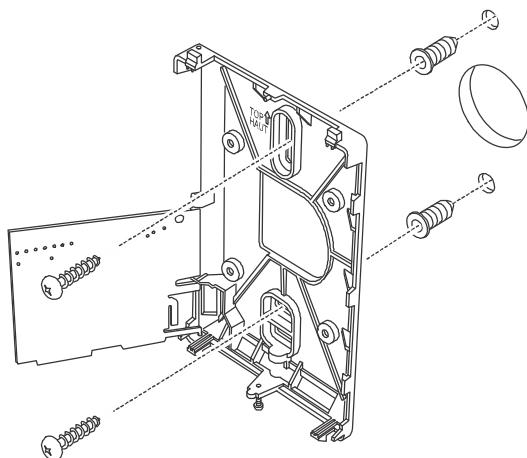

Figure 4: Mounting the Sensor Base

Wiring



CAUTION: Risk of Electric Shock.

Disconnect the power supply before making electrical connections to avoid electric shock.

Note: Keep sensor conductors as short as possible to minimize temperature error. If necessary, the indoor temperature displayed at the thermostat can be adjusted (refer to the appropriate T600 or TEC2000 Series Installation Instructions).

To wire the sensor:

1. Connect wires between the T600 or TEC2000 Series thermostat and the SEN-600-1 or SEN-600-4 sensors according to the appropriate wiring diagram (see Figure 5).
2. Set the switch on the PCB in the remote indoor sensor to the correct positions (see Table 1 for switch positions).
3. Reattach the sensor cover to the installed base (top side first) and install the security screw on the bottom.
4. Verify that the sensor is functioning by checking the temperature display on the T600 or TEC2000 Series thermostat. If using the SEN-600-4 remote sensor, verify the functionality of the override button and occupancy status LED.

Note: If using the SEN-600-4, the digital input on the thermostat to which the D1 terminal on the sensor is connected must be configured for remote override (RemOVR). Refer to the appropriate T600 Installation Instructions for details on configuring the digital input.



CAUTION: Risk of Property Damage.

Do not apply power to the system before checking all wiring connections. Short circuited or improperly connected wires may result in permanent damage to the equipment.

Table 1: Switch Positions for Single or Multiple Sensor Installations

Number of Sensors	Switch 1	Switch 2
1 Sensor	On	On
2 Sensors	Off	On
3 Sensors	Off	Off



This is a wiring example of a single remote room sensor (S1=On, S2=On).

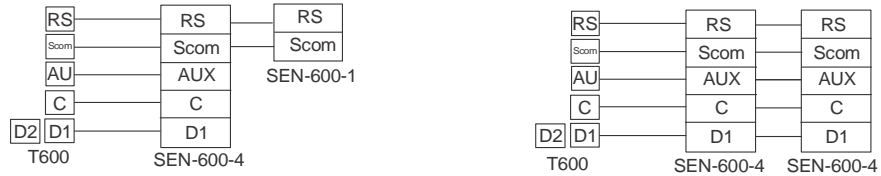
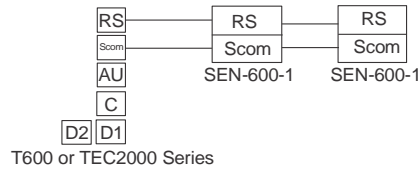

This is a wiring example of two remote room sensors for averaging applications (S1=Off, S2=On).

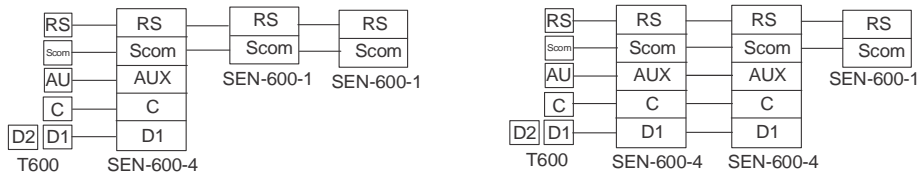
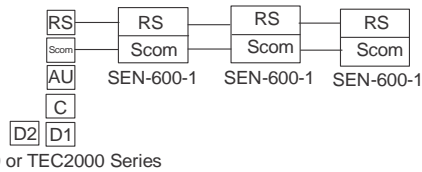

This is a wiring example of three remote room sensors for averaging applications (S1=Off, S2=Off).

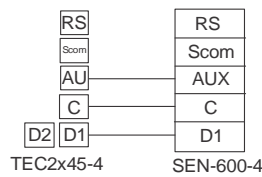

This is a wiring example of a single remote room sensor for TEC2x45-4 applications (S1=On, S2=On).

IMPORTANT: The SEN-600-1 is not compatible with TEC2x45-4 thermostat models. On SEN-600-4 sensors, only the remote override function is compatible with TEC2x45-4 thermostat models.

Note: When wiring the SEN-600-4 remote indoor sensor to a non-programmable model of the T600, the AUX terminal on the SEN-600-4 is not used. Additionally, when using the SEN-600-4 remote indoor sensor with a non-programmable model of the T600, the LED does not light to indicate occupancy status.

Figure 5: Wiring Diagrams

Troubleshooting

Table 2: Troubleshooting

Symptom	Possible Cause	Corrective Action
Temperature displayed at the T600 or TEC2000 Series does not correlate with the temperature at the remote sensor.	Remote sensor is not correctly connected.	Check wiring connections at the thermostat terminal blocks and between the thermostat and the remote sensor.
	T600, TEC2000 Series, or remote sensor has failed.	Short the appropriate sensor terminals at the thermostat. The display should indicate 122°F (50°C). If the reading is not 122°F (50°C), replace the thermostat. If the reading is 122°F (50°C), check the resistance across the sensor with the wires removed from the thermostat. The resistance should be 10,000 ohms at 77°F (25°C). If the resistance is not correct, replace the sensor.
Override button on SEN-600-4 remote sensor is not functional.	SEN-600-4 is incorrectly wired to the thermostat.	Check wiring connections with the corresponding digital input at the thermostat, at the D1 terminal on the remote sensor, and between the thermostat and remote sensor.
	The appropriate digital input on the thermostat is not configured to remote override (RemOVR).	Configure the appropriate digital input at the thermostat for remote override (RemOVR). Refer to the appropriate T600 Installation Instructions for details.
Remote LED is not functional on the SEN-600-4 remote sensor.	SEN-600-4 is incorrectly wired to the thermostat.	Check wiring connections at the auxiliary output at the programmable T600 thermostat, at the AUX terminal on the remote sensor, and between the thermostat and remote sensor.
	The auxiliary output is not properly configured at the T600 programmable thermostat.	Configure the auxiliary output at the T600 programmable thermostat for Normally Open (N.O.). Refer to the appropriate T600 Installation Instructions for details.
	The T600 Series thermostat to which the SEN-600-4 is connected is not a programmable model.	The LED does not indicate occupancy status on non-programmable T600 models (there is no auxiliary contact at the thermostat). Replace the T600 with a programmable model.

Technical Specifications

SEN-600-1 and SEN-600-4 Remote Indoor Temperature Sensors

Power Requirements	Supplied by the T600 or TEC2000 Series Thermostat
Sensor Accuracy	±0.9 F° from 32 to 158°F; ±0.5 C° from 0 to 70°C
Sensor Ambient Operating Conditions	32 to 122°F (0 to 50°C); 0 to 95% RH noncondensing
Sensor Ambient Storage Conditions	-22 to 122°F (-30 to 50°C); 0 to 95% RH noncondensing
Dimensions (H x W x D)	4.94 x 3.38 x 1.13 in. (125 x 86 x 29 mm)
Shipping Weight	0.75 lb (0.34 kg)

The performance specifications are nominal and conform to acceptable industry standards. For application at conditions beyond these specifications, consult the local Johnson Controls® office. Johnson Controls, Inc. shall not be liable for damage resulting from misapplication or misuse of its products.



Building Efficiency
507 E. Michigan Street, Milwaukee, WI 53202

Metasys® and Johnson Controls® are registered trademarks of Johnson Controls, Inc. All other marks herein are the marks of their respective owners. © 2013 Johnson Controls, Inc.