

M9102-AGA-1S and M9104-xGA-1S Series Electric Non-Spring Return Actuators

Installation Instructions

Part No. 34-636-1506, Rev. D
Issued December 28, 2007
Supersedes December 12, 2006

Applications

The M9102 and M9104 Series Actuators are direct-mount, non-spring return electric actuators that operate on AC 24 V power. Employing a synchronous motor, these actuators provide floating control (AGA), floating control with automatic shut-off (IGA), and proportional control with selectable 0-10 or 2-10 VDC (GGA).

All models are compact in size, and are easily installed on Variable Air Volume (VAV) boxes, Variable Air Volume and Temperature (VVT) two-position zone applications, or small to medium-sized dampers with a round shaft up to 13 mm in diameter, or a 10 mm square shaft.

The M9102 Series Electric Non-Spring Return Actuators provide a running torque of 2 N·m, and the nominal travel time is 36 seconds at 50 Hz for 90° of rotation.

The M9104 Series Electric Non-Spring Return Actuators provide a running torque of 4 N·m, and the nominal travel time is 72 seconds at 50 Hz for 90° of rotation.

IMPORTANT: Use this M9102 or M9104 Series Electric Non-Spring Return Actuator only to control equipment under normal operating conditions. Where failure or malfunction of the electric actuator could lead to personal injury or property damage to the controlled equipment or other property, additional precautions must be designed into the control system. Incorporate and maintain other devices such as supervisory or alarm systems or safety or limit controls intended to warn of, or protect against, failure or malfunction of the electric actuator.

Installation

The M9102 and M9104 Series Electric Non-Spring Return Actuators mount directly to the surface in any convenient orientation using a single No. 10 self-drilling sheet metal screw (included with the actuator). No additional linkages or couplers are required. Electrical connections on the actuator are clearly labeled to simplify installation.

IMPORTANT: Before specifying M9102 or M9104 Series Electric Non-Spring Return Actuators for plenum applications, verify acceptance of exposed plastic materials in plenum areas with the local building authority. Building codes for plenum requirements vary by location. Some local building authorities accept compliance to UL 1995, Heating and Cooling Equipment, while others use different acceptance criteria.

IMPORTANT: Do not install or use this M9102 or M9104 Series Electric Non-Spring Return Actuator in or near environments where corrosive substances or vapors could be present. Exposure of the electric actuator to corrosive environments may damage the internal components of the device, and will void the warranty.

Parts Included

- one electric non-spring return actuator with an integrated 1.2 m (48 in.) long cable
- one No.10 self-drilling sheet metal screw

Special Tools Needed

- 8 mm square socket
- #2 Phillips screwdriver
- 10 mm 12-point socket
- drill with a 8 mm hex nut driver
- digital voltmeter or M9000-200 Commissioning Tool

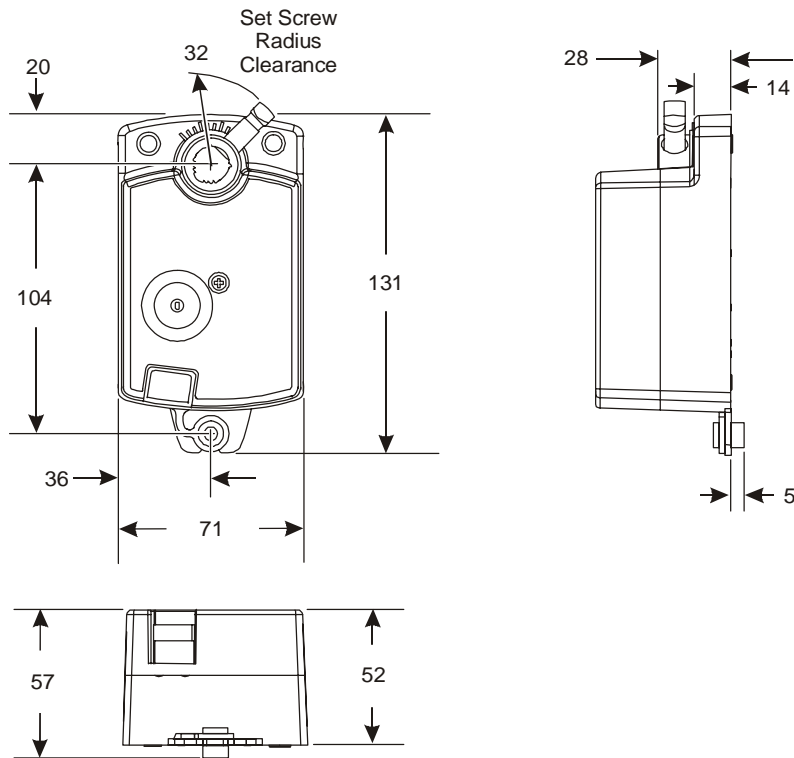

Figure 1: M9102 and M9104 Series Electric Non-Spring Return Actuator Dimensions, mm

Accessories

Table 1: Accessories (Order Separately)

Code Number	Description
M9000-200	Commissioning Tool that Provides a Control Signal to Drive 24 V On/Off, Floating, Proportional, and/or Resistive Electric Actuators

Mounting

To mount the actuator to a damper:

1. Check that the damper blade is visually accessible, or its position is permanently marked on the end of the damper shaft, as illustrated in Figure 2.

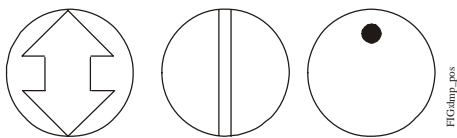

Figure 2: Damper Position Icons

2. Grasp the damper shaft firmly with pliers and rotate the damper fully closed, as illustrated in Figure 3.

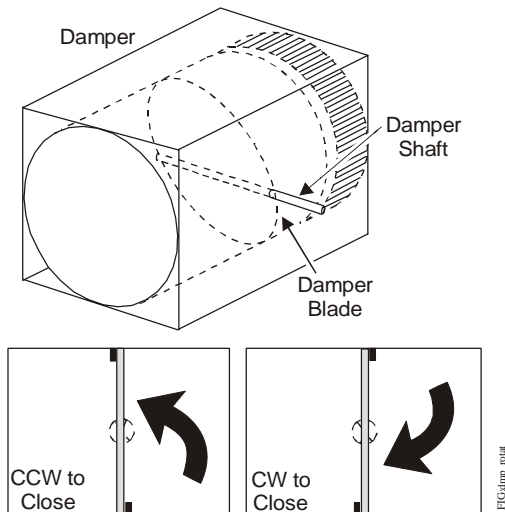

Figure 3: Damper Rotation

3. Press and hold the gear release lever, and rotate the actuator coupler to the fully closed position.
4. Make a note of the rotation range and direction, either Clockwise (CW) or Counterclockwise (CCW), required to close the damper.

- Position the actuator onto the damper shaft so that the damper shaft protrudes through the actuator coupler, as illustrated in Figure 4.

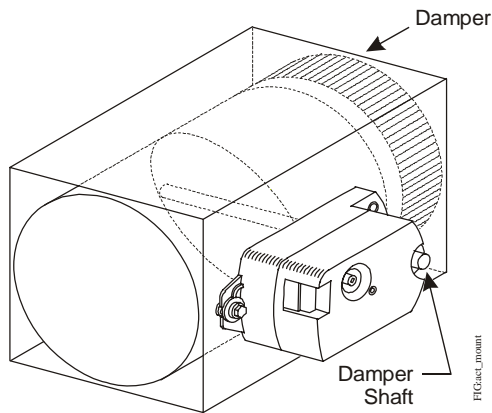

Figure 4: Mounting the Actuator onto the Damper Shaft

- Be certain that the actuator is in the desired mounting position parallel to the mounting surface, as illustrated in Figure 5.

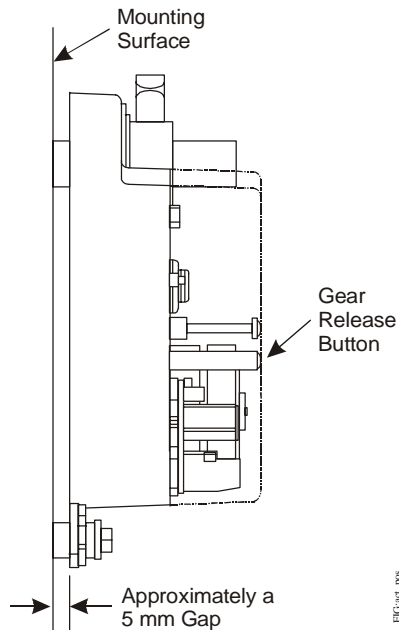

Figure 5: Positioning the Actuator

- Hold the actuator in place on the damper shaft, and insert the No. 10 self-drilling sheet metal screw through the shoulder washer as illustrated in Figure 6.

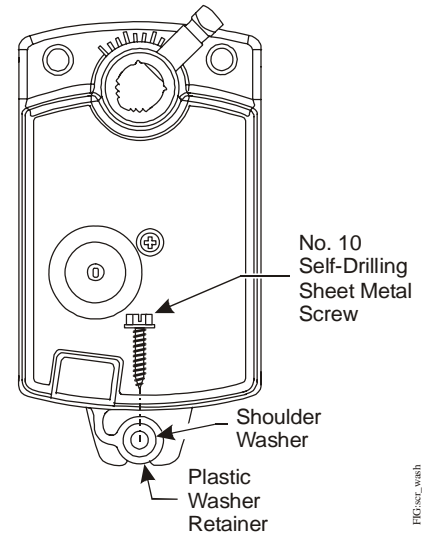

Figure 6: Inserting the Screw into the Shoulder Washer

- Place a 8 mm socket on the screw and use a drill and extension to drill the screw into the mounting surface. Drive the screw until it is tight against the washer.

IMPORTANT: Do not overtighten the mounting screw. Overtightening may strip the threads.

- Tighten the square coupler bolt to the shaft using an 8 mm (5/16 in.) wrench or 10 mm (3/8 in.) 12-point socket. Tighten to 11 to 15 N·m (100 to 130 lb·in).

Wiring

M9102-AGA-1S, M9104-AGA-1S

The M9102 and M9104 Series Electric Non-Spring Return Actuators require an AC 24 V input signal and are compatible with a variety of VAV and VVT controllers. These electric actuators include an integrated 1.2 m (48 in.) long cable. See Figure 7 for proper wiring.

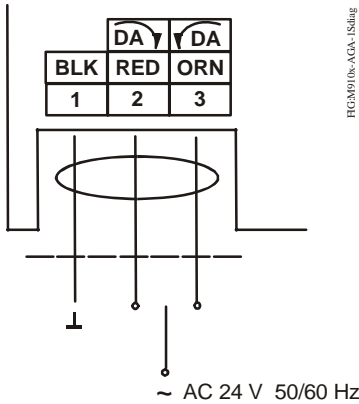

Figure 7: M9102-AGA-1S and M9104-AGA-1S Control Wiring Diagram

Note: When using an AGA model, you must use a VAV or VVT controller and/or software that provides a timeout function at the end of rotation (stall) to avoid excessive wear or drive time on the actuator motor.

M9104-IGA-1S

The M9104-IGA Series Electric Non-Spring Return valve actuators require an AC 24 V input signal and work with a variety of controllers. These electric actuators include an integrated 1.2 m (48 in.) long cable and have an auto-shutoff feature to prevent excessive wear or drive time on the motor. See Figure 8 and Figure 9 for proper wiring options.

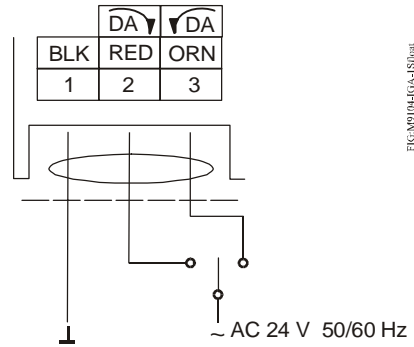

Figure 8: M9104-IGA-1S Control Wiring Diagram - Floating

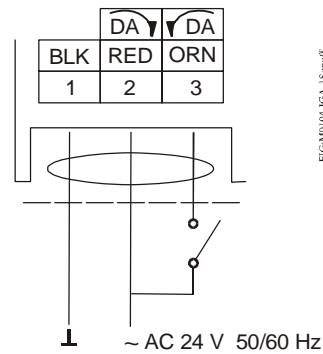

Figure 9: M9104-IGA-1S Control Wiring Diagram - On/Off

M9104-GGA-1S

The M9104-GGA Series Electric Non-Spring Return valve actuators require AC 24 V power and a DC 0(2) to 10 V or DC 0(4) to 20 mA controller input signal. These electric actuators include an integrated 1.2 m (48 in.) long cable. See Figure 10 for proper wiring.

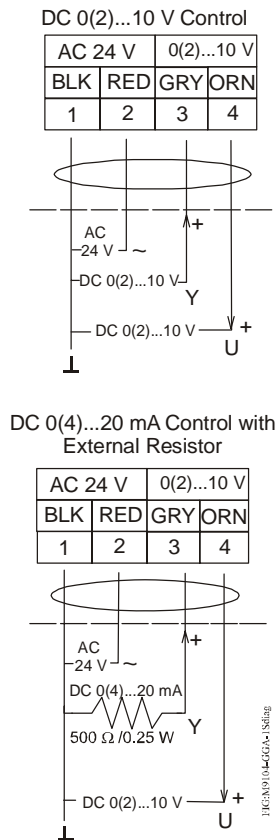

Figure 10: M9104-GGA-1S Control Wiring Diagram

M9104-GGA actuators are factory set for Direct Acting (DA) mode and for a DC 0 to 10 V input control signal. In DA mode, a minimum control signal drives the actuator to the full Counterclockwise (CCW) position, and a maximum control signal drives the actuator to the full Clockwise (CW) position.

For Reverse Acting (RA) operation, a minimum control signal drives the actuator to the full CW position and a maximum signal drives the actuator to the full CCW position.

To change the factory settings (DA, 0-10 V), remove the actuator cover and adjust the switches on the circuit board as shown in Figure 12.

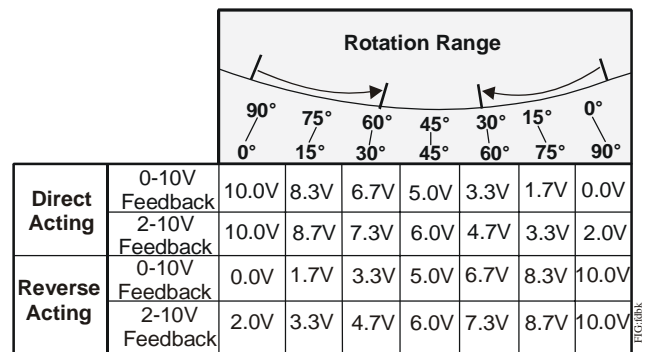

Figure 11: Feedback Signal Relative to the Rotation Range

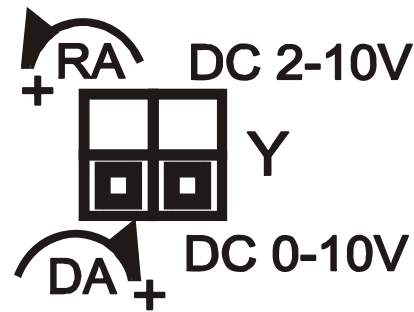

Figure 12: M9104-GGA Factory Switch Setting



CAUTION: Risk of Electric Shock. Disconnect the power supply before making electrical connections to avoid electric shock.



CAUTION: Risk of Property Damage. Do not apply power to the system before checking all wiring connections. Short circuited or improperly connected wires may result in permanent damage to the equipment.

IMPORTANT: Make all wiring connections in accordance with local, national, and regional regulations. Do not exceed the electrical ratings of the M9102 or M9104 Series Electric Non-Spring Return Valve Actuator.

Setup and Adjustments

Commissioning

After wiring is completed, apply power to the VAV or VVT controller and provide input signals to the actuator to drive it at least one complete cycle open and closed.

Troubleshooting

If the M9102 or M9104 Series Electric Non-Spring Return Actuator is not responding or working properly:

- verify that the actuator assembly is properly secured to the duct
- check that all electrical connections are complete and that power is applied

- verify that the damper fully opens and closes, using the gear release button on the actuator
- check that the actuator stroke is set for the desired application

Repairs and Replacement

If the M9102 or M9104 Series Electric Non-Spring Return Actuator fails to operate within its specifications, replace the unit. For a replacement electric actuator, contact the nearest Johnson Controls® representative.

Technical Specifications

M9102-AGA-1S and M9104-xGA-1S Series Electric Non-Spring Return Actuators (Part 1 of 2)

Power Requirements	M910x-AGA-1S	AC 24 V +25%/-20% at 50/60 Hz, 2.1 VA, Class 2, Safety Extra-Low Voltage (SELV)
	M9104-IGA-1S	AC 24 V +25%/-20% at 50/60 Hz, 3.0 VA, Class 2, SELV
	M9104-GGA-1S	AC 24 V +25%/-20% at 50/60 Hz, 3.6 VA, Class 2, SELV (Class III)
Control Type	M910x-AGA-1S	Floating Control without Timeout
	M9104-IGA-1S	Floating or On/Off Control with Timeout
	M9104-GGA-1S	Proportional Control
Input Signal	M9102-AGA-1S	AC 24 V +25%/-20% at 50/60 Hz, Class 2, SELV
	M9104-AGA-1S	AC 24 V +25%/-20% at 50/60 Hz, Class 2, SELV
	M9104-IGA-1S	AC 24 V +25%/-20% at 50/60 Hz, Class 2, SELV
	M9104-GGA-1S	DC 0 (2) to 10 V or 0 (4) to 20 mA with field furnished 500 ohm resistor
Feedback Signal	M9104-GGA-1S	0 to 10 VDC or 2 to 10 VDC for 90° (10 VDC at 1 mA) Corresponds to input signal span selection
Motor Input Impedance		200 ohms Nominal
Running Torque	M9102 Series	2 N·m
	M9104 Series	4 N·m
Travel Time	M9102 Series	36 seconds at 50 Hz for 90° of rotation
	M9104 Series	72 seconds at 50 Hz for 90° of rotation
Rotation Range		93° ±3°, CW or CCW
Cycles		100,000 Full Stroke Cycles; 2,500,000 Repositions at Rated Running Torque
Audible Noise Rating		35 dBA Nominal at 1 m
Electrical Connections	M9104-AGA-1S M9104-IGA-1S	1.2 m (48 in.) Polyvinyl Chloride (PVC) cable with 0.75 mm ² conductors (19 AWG) and 6 mm (.25 in.) ferrule ends
	M9104-GGA-1S	1.2 m (48 in.) PVC cable with 0.75 mm ² conductors (19 AWG) and 6 mm (.25 in.) ferrule ends
Mechanical Connections		Up to 13 mm Diameter Round Damper Shaft or 10 mm Square Damper Shaft
Enclosure		IP42, NEMA 2
Ambient Conditions	Operating	-20 to 60°C; 90% RH Maximum, Noncondensing
	Storage	-29 to 66°C; 90 RH Maximum, Noncondensing

M9102-AGA-1S and M9104-xGA-1S Series Electric Non-Spring Return Actuators (Part 2 of 2)

Compliance	North America	UL Listed, File E27734, CCN XAPX (United States) and XAPX7 (Canada) Actuator Housing is Plenum Rated per CSA C22.2 No. 236/UL 1995, Heating and Cooling Equipment
	European Union	CE Mark, EMC Directive 89/336/EEC
	Australia and New Zealand	C-Tick Mark, Australia/NZ Emissions Compliant
	Shipping Weight	0.5 kg

The performance specifications are nominal and conform to acceptable industry standards. For application at conditions beyond these specifications, consult the local Johnson Controls office. Johnson Controls, Inc. shall not be liable for damages resulting from misapplication or misuse of its products.



Controls Group
507 E. Michigan Street
Milwaukee, WI 53202

*Metasys® is a registered trademark of Johnson Controls, Inc.
All other marks herein are the marks of their respective owners.
© 2006 Johnson Controls, Inc.*