

# TE-6300M Series Duct Probe Temperature Sensors

## Installation Instructions

TE-631xM-1, TE-635xM-1  
TE-636xM-1

Part No. 24-4034-166, Rev. D  
Issued February 14, 2012  
Supersedes April 6, 2010

Refer to the [QuickLIT Web site](#) for the most up-to-date version of this document.

### Applications

**IMPORTANT:** The TE-6300M Series Duct Probe Temperature Sensors are intended to provide an input to equipment under normal operating conditions. Where failure or malfunction of the sensor could lead to personal injury or property damage to the controlled equipment or other property, additional precautions must be designed into the control system. Incorporate and maintain other devices, such as supervisory or alarm systems or safety or limit controls, intended to warn of or protect against failure or malfunction of the sensor.

### Installation

**IMPORTANT:** Do not install the TE-6300M Series Duct Probe Temperature Sensor in ambient temperatures beyond the specified  $-50$  to  $220^{\circ}\text{F}$  ( $-46$  to  $104^{\circ}\text{C}$ ) temperature range. Installing the temperature sensor in ambient temperatures beyond this range may damage the unit and void the warranty.

### Dimensions

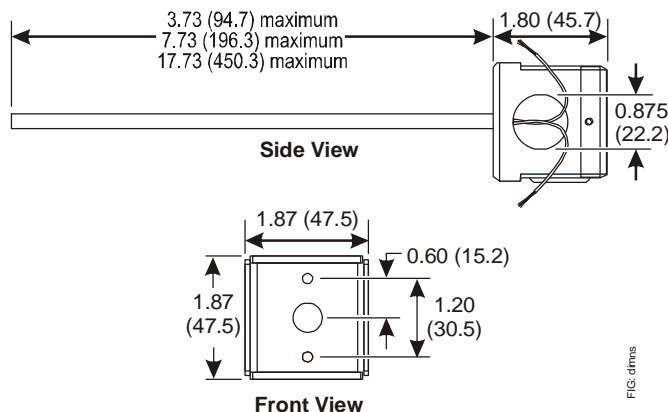

Figure 1: Sensor Dimensions, in. (mm)

### Mounting

#### Location Considerations

Consider the following mounting location guidelines:

- Avoid areas subject to excessive vibration, electrical noise, direct sunlight, or the effects of radiant heat.
- Keep electrical wiring as short as possible to minimize temperature error.

#### Mounting the Temperature Sensor

See Figure 2 and mount the temperature sensor as follows:

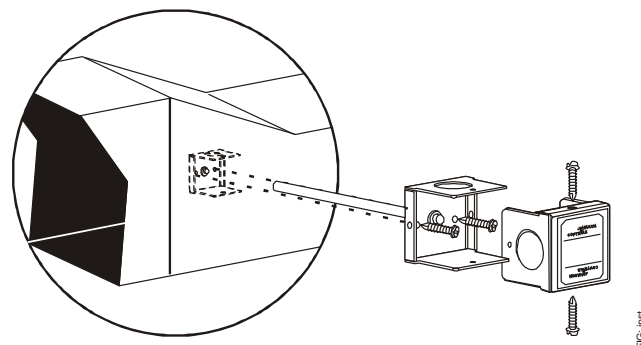

Figure 2: Installing the Duct Probe Sensor

1. Drill a  $3/8$  in. (10 mm) diameter hole at the desired mounting location.
2. Insert the probe into the duct and mount the probe assembly using the two self-drilling screws included.
3. Wire the sensor to the controller.
4. Reposition the cover and tighten the retention screws.

### Wiring

For 1k ohm nickel temperature sensors, wire resistance can cause approximately  $1\text{F}^{\circ}$  ( $0.56\text{C}^{\circ}$ ) of error for every 250 ft (76 m) run of 18 AWG wire, or every 100 ft (31 m) run of 22 AWG wire.

For 1k ohm platinum temperature sensors, wire resistance can cause approximately 1F° (0.56 C°) of error for every 150 ft (46 m) run of 18 AWG wire, or every 50 ft (15 m) run of 22 AWG wire.

To minimize error due to field wiring, limit the total resistance of all nickel temperature sensor wiring to 3 ohms, and all platinum temperature sensor wiring to 2 ohms.

Refer to the appropriate controller documentation for recommended sensor wiring. Secure the wiring bushing or conduit only to the base of the temperature sensor. See Table 1 for an explanation of the lead wiring color convention.

**Table 1: Lead Wiring (22 AWG, 6 in.) Color Code**

Sensor Type	Lead Color
1k ohm Nickel	White
1k ohm Platinum	White with Blue Stripe
10k ohm Type II Thermistor	White with Green Stripe

## Technical Specifications

### TE-6300M Series Adjustable Length Duct Probe Temperature Sensors

<b>Models</b>	<b>TE-631xM-1</b>	Thin-Film Nickel Temperature Sensor
	<b>TE-635xM-1</b>	Thin-Film Platinum Temperature Sensor
	<b>TE-636xM-1</b>	10k ohm Type II Thermistor Temperature Sensor
<b>Sensor Reference Resistance</b>	<b>1k ohm Nickel</b>	1k ohms at 70°F (21°C)
	<b>1k ohm Platinum</b>	1k ohms at 32°F (0°C)
	<b>Thermistor</b>	10.0k ohms at 77°F (25°C)
<b>Sensor Accuracy</b>	<b>1k ohm Nickel</b>	±0.34F° at 70°F (±0.19C° at 21°C)
	<b>1k ohm Platinum</b>	±0.35F° at 70°F (± 0.19C° at 21°C), DIN Class A
	<b>Thermistor</b>	±0.9F° (±0.59 C°) in the range: 32 to 158°F (0 to 70°C)
<b>Sensor Temperature Coefficient</b>	<b>1k ohm Nickel</b>	Approximately 3 ohms/F° (5.4 ohms/C°)
	<b>1k ohm Platinum</b>	Approximately 2 ohms/F° (3.9 ohms/C°) 3850 ppm/K
	<b>10k ohm Thermistor</b>	Nonlinear Negative Temperature Coefficient, Johnson Controls Type II
<b>Materials</b>	<b>Probe</b>	1/4 in. (6.4 mm) Outer Diameter x 4 in. (102 mm), 8 in. (203 mm), or 18 in. (457 mm) Long Stainless Steel
	<b>Conduit Access Box</b>	Galvanized Steel
<b>Operating Conditions</b>		-50 to 220°F (-46 to 104°C)

*The performance specifications are nominal and conform to acceptable industry standards. For application at conditions beyond these specifications, consult the local Johnson Controls office. Johnson Controls, Inc. shall not be liable for damages resulting from misapplication or misuse of its products.*



#### **CAUTION: Risk of Property Damage.**

Do not apply power to the system before checking all wiring connections. Short circuited or improperly connected wires may result in permanent damage to the equipment.

**IMPORTANT:** Use copper conductors only. Make all wiring connections in accordance with local, national, and regional regulations. Do not exceed the TE-6300M Series Duct Probe Temperature Sensor's electrical ratings.

## Repair Information

If the TE-6300M Series Duct Probe Temperature Sensor fails to operate within its specifications, replace the unit. For a replacement sensor, contact the nearest Johnson Controls® representative.



**Building Efficiency**  
507 E. Michigan Street, Milwaukee, WI 53202

*Metasys® and Johnson Controls® are registered trademarks of Johnson Controls, Inc. All other marks herein are the marks of their respective owners. © 2012 Johnson Controls, Inc.*