

# CTD Series Current Transducer Devices

## Installation Instructions

CTD-C1G00-1, CTD-C2G00-1, CTD-C3H00-1

Part No. 24-10345-69, Rev. B

Issued April 5, 2013

Supersedes July 20, 2011

Refer to the [QuickLIT website](#) for the most up-to-date version of this document.

### Applications

The Current Transducer Device (CTD) Series of analog output current transducers are nonintrusive devices designed to detect current flowing through a cable or wire. These units are a cost-effective solution for monitoring load or proof of operation. The current transducers are ideal for monitoring current loads on pumps, driving fans and blowers, and sensing the status of heating coils and lighting. CTD devices used for load trending over time are effective sensors for predictive maintenance programs.

Optional command relays provide externally controlled auxiliary contacts. The relays offer a solution for switching loads that require higher power levels than the rating of the current switch contacts.

These units are available with standard 4 to 20 mA current loop, 0 to 5 VDC, and 0 to 10 VDC analog output. Completely self-powered, the CTD-C2G00-1 and CTD-3H00-1 units draw their power from the current induced from the monitored cable or line. The CTD-C1G00-1 device requires a 24 VDC power supply.

**IMPORTANT:** The CTD Series Current Transducer Devices are intended to provide an input to equipment under normal operating conditions. Where failure or malfunction of the current transducer device could lead to personal injury or property damage to the controlled equipment or other property, additional precautions must be designed into the control system. Incorporate and maintain other devices, such as supervisory or alarm systems or safety or limit controls, intended to warn of or protect against failure or malfunction of the current transducer device.



**CAUTION: Risk of Property Damage.** Install the CSD Series Current Devices only on the input side of a variable speed drive. Failure to follow this precaution may result in excessive wear on the controlled equipment, as well as premature failure of the CSD Series Current Devices.

### Installation



**WARNING: Risk of Electric Shock.** Disconnect the power supply before making electrical connections. Contact with components carrying hazardous voltage can cause electric shock and may result in severe personal injury or death.



**WARNING: Risk of Personal Injury.** Do not touch the relay while power is applied to it. The relay surface is hot during use, and may cause a serious burn upon contact.

### Dimensions

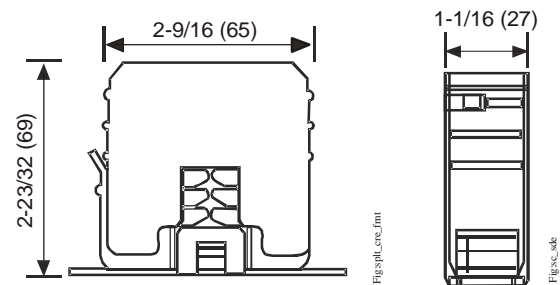


Figure 1: CTD Dimensions, in. (mm)

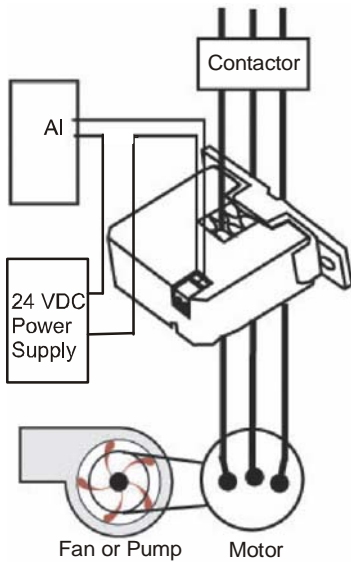
### Mounting

1. Use the two screws (included) to attach the mounting bracket to the back of the electrical enclosure.
2. Snap the CTD device into place on the mounting bracket.

### Wiring

1. Disconnect the conductor cable from the power source.
2. Snap the split core around the power conductor cable, and close the core until the core snaps shut.
3. Wire the CTD output terminals to the control box Analog Input (AI) terminal. See [Technical Specifications](#) for wire size and screw torque.

4. Select the input current range at the front panel slide switch. See Figure 5 and [Setting the Current Range](#) section.
5. Reconnect the power conductor cable. For a wiring example, see Figure 2.

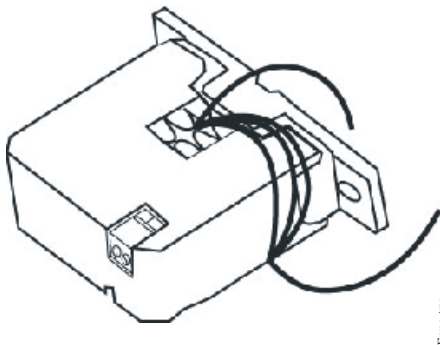


**Figure 2: Model CTD-C1G00-1**

If the measured current is too low to be detected or it is higher than the maximum current rating of the CTD device, use the following methods to increase or decrease the current.

***If Measured Current Is Too Low to Be Detected***

Wrap the conductor (wire) through the sensing hole and around the CTD body to produce multiple turns to increase the measured current. The measured current is equal to the actual current multiplied by the number of turns (Figure 3).



**Figure 3: CSD Device Shown with Four Turns**

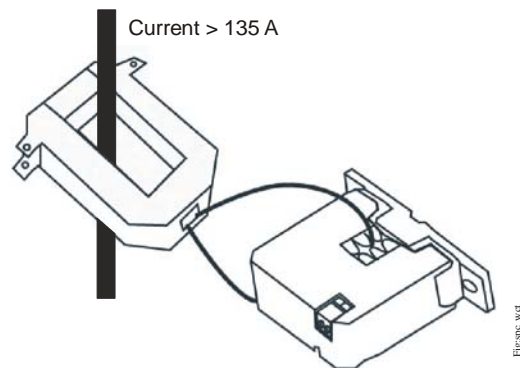
You must scale the controller to account for the extra turns. If four turns pass through the transducer as shown, the normal controller reading must be divided by 4.

**IMPORTANT:** Failure to derate the current capacity could result in damage to the CTD device when using multiple turns to increase the measured current. Use the following formula to determine the new maximum current:  
 The new maximum current is equal to the CDT current rating divided by the number of turns.  
 Example: If the new maximum current is equal to the CDT current rating of 120 A, then  
 Maximum Current = 120 A / 4 = 30 A.

***To Monitor Currents Exceeding the Maximum Current Rating of the CTD Device***

For currents greater than 120 A (CTD-C1G00-1 and CTD-C200-1), or greater than 150 A (CTD-C3H00-1), proceed as follows.

1. Use a 5 A Current Transformer (CT) to reduce the current passing through the CTD device, as shown in Figure 4.
2. Run the CT secondary wire through the sensing hole.
3. Terminate the two secondary wires of the 5 A CT to each other, and then install the 5 A CT on the monitored conductor.
4. Set the CTD device for the lowest current range (20 or 30 A).



**Figure 4: CTD Device with CT Transformer**

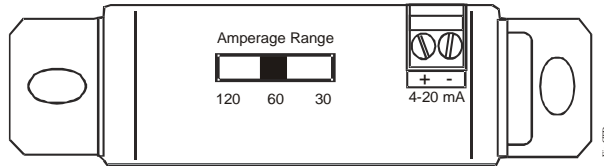
## Setup and Adjustments

### Setting the Current Range

Position the current range slide switch to a level consistent with the load.

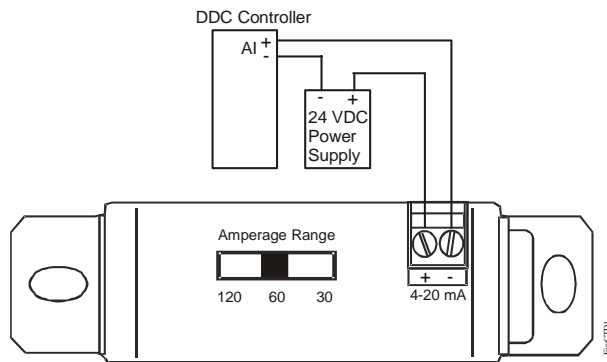
**Table 1: Current Settings**

Model	Current Settings (A)
CTD-C1G00-1	30, 60, or 120
CTD-C2G00-1	30, 60, or 120
CTD-C3H00-1	20, 100, or 150

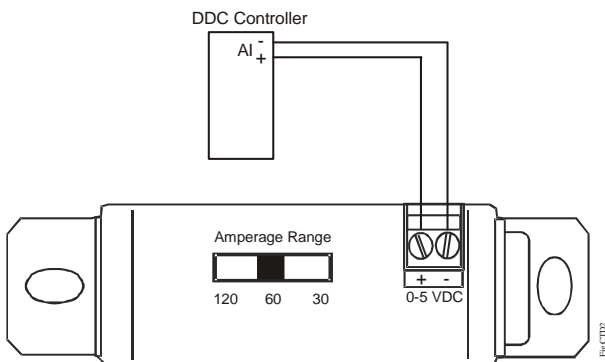


**Figure 5: Current Setting Switch**

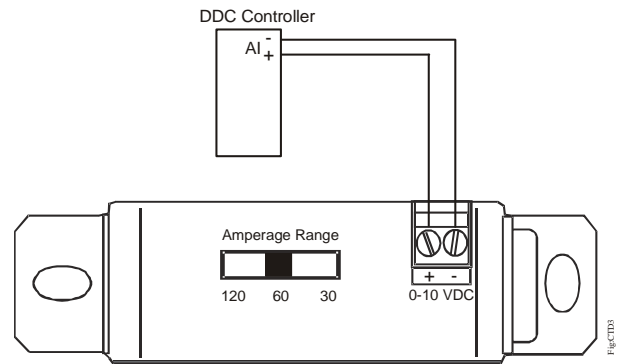
### Wiring and Output



**Figure 6: CTD-C1G00-1**

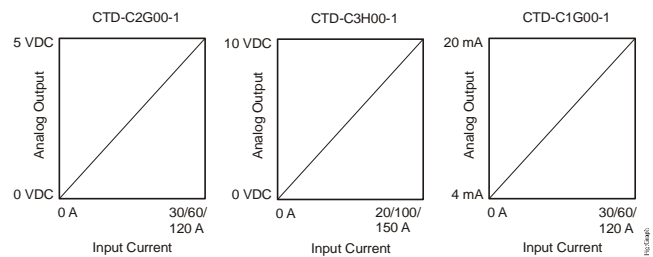


**Figure 7: CTD-2G00-1**



**Figure 8: CTD-C3H00-1**

### Linear Outputs



**Figure 9: Transducer Linear Outputs**

### Accessories

See Table 2 for accessories.

**Table 2: Accessories**

Code Number	Description
CR-01200-0	12 VAC/VDC Single-Pole, Single-Throw (SPST), Normally Open (N.O.) Relay
CR-02400-0	24 VAC/VDC SPST, N.O. Relay

### Repair Information

If the CTD Device fails to operate within its specifications, replace the unit. For a replacement CTD device, contact the nearest Johnson Controls® representative.


## Troubleshooting

Table 3: Troubleshooting

Symptom		Action
The CTD device output does not function.		Verify you did not exceed the maximum current range. Voltages or currents above the rated levels may damage the CTD device.
There is no CTD output at controller.	CTD-C1G00-1	<ol style="list-style-type: none"> <li>Verify that the loop power between the CTD terminals and the control panel analog input is 18–30 VDC.</li> <li>Verify that the current is 4 mA without a load.               <ol style="list-style-type: none"> <li>Turn off the monitored load.</li> <li>Disconnect the inputs to the controller.</li> <li>Measure the current in the power supply and CTD output loop with a multimeter.</li> </ol> </li> <li>Check the current loop polarity.</li> <li>Check the clamp surface is free of dirt or debris.</li> <li>Check the clamp is fully closed.</li> </ol>
	CTD-C2G00-1, CTD-C3H00-1	<ol style="list-style-type: none"> <li>Check the current rating in monitored conductor.</li> <li>Check the polarity of the sensor output and controller output.</li> <li>Check the clamp surface is free of dirt or debris.</li> <li>Check the clamp is fully closed.</li> <li>Measure the voltage across the CTD output terminals.</li> </ol>

## Technical Specifications

### CTD-C1G00-1, CTD-C2G00-1, and CTD-C3H00-1 Current Transducer Models

Product Code	CTD-C1G00-1	CTD-C2G00-1	CTD-C3H00-1
Current Range (Selectable)	30/60/120 A	30/60/120 A	20/100/150 A
Continuous Operating Current	30/60/120 A	30/60/120 A	20/100/150 A
Output	4 to 20 mA	0 to 5 VDC	0 to 10 VDC
Accuracy	±2.0% Full Scale from 10% to 100% of Selected Range		
Response Time	2 Seconds to 100% of Selected Range		
Sensor Supply Voltage	24 VDC (18 to 30 VDC)	Self-Powered	Self-Powered
Wire Size	12 to 22 AWG (2.1 to 0.6 mm) Diameter Recommended		
Isolation Voltage	600 VAC rms		
Temperature Range	5 to 140°F (-15 to 60°C)		
Frequency Range	50/60 Hz		
Humidity Range	0 to 95% RH, Noncondensing		
Screw Torque	4 lb-in (0.5 N·m)		
Dimensions	2-23/32 x 2-9/16 x 1-1/16 in. (69 x 65 x 27 mm)		
Aperture (Sensing Hole) Size	23/32 in. x 13/16 in. (18 x 20 mm Diameter)		
Compliance  	United States	UL Listed, File E310692, CCN NRNT, Under UL 508, Industrial Control Equipment	
	Canada	UL Listed, File E310692, CCN NRNT7, Under CAN/CSA C22.2 No. 14-05 Industrial Control Equipment	
	Europe	CE Mark – Johnson Controls, Inc., declares that this product is in compliance with the essential requirements and other relevant provisions of the EMC Directive 2004/108/EC and the Low Voltage Directive 2006/95/EC.	
Shipping Weight	0.35 lb (0.16 kg)		

The performance specifications are nominal and conform to acceptable industry standards. For application of conditions beyond these specifications, consult the local Johnson Controls office. Johnson Controls, Inc. shall not be liable for damages resulting from misapplication or misuse of its products.



### Building Efficiency

507 E. Michigan Street, Milwaukee, WI 53202

Metasys® and Johnson Controls® are registered trademarks of Johnson Controls, Inc. All other marks herein are the marks of their respective owners. © 2013 Johnson Controls, Inc.