



P266 Series Single-Phase Condenser Fan Speed Controls

Installation Instructions

P266xxA-xx

Part No. 24-7664-2705, Rev. F

Issued April 26, 2012

Supersedes September 3, 2010

Refer to the [QuickLIT Web site](#) for the most up-to-date version of this document.

Application

The P266 Series Single-Phase Condenser Fan Speed Controls are cost-effective, weather-resistant, durable motor speed controls. The P266 Series Controls are designed for approved single-phase, Permanent Split-Capacitor (PSC) motors commonly used in a wide variety of refrigeration and air conditioning condenser fan applications.

The P266 Series Controls are designed to replace the Johnson Controls® P66 Series and P215 Series Fan Speed Controls, providing additional features and flexibility, greater energy efficiency, and longer motor life in a compact, rugged, weather-resistant package.

IMPORTANT: Use this P266 Series Single-Phase Condenser Fan Speed Control only as an operating control. Where failure or malfunction of the fan speed control could lead to personal injury or property damage to the controlled equipment or other property, additional precautions must be designed into the control system. Incorporate and maintain other devices, such as supervisory or alarm systems or safety or limit controls, intended to warn of or protect against failure or malfunction of the fan speed control.



CAUTION: Risk of Property Damage

Use only single-phase PSC motors approved by the manufacturer for speed control applications with the P266 Series Control. Failure to use a single-phase PSC motor may damage the motor and other property.

North American Emissions Compliance

United States

This equipment has been tested and found to comply with the limits for a Class A digital device pursuant to Part 15 of the FCC Rules. These limits are designed to provide reasonable protection against harmful interference when this equipment is operated in a commercial environment. This equipment generates, uses, and can radiate radio frequency energy and, if not installed and used in accordance with the instruction manual, may cause harmful interference to radio communications. Operation of this equipment in a residential area is likely to cause harmful interference, in which case the user will be required to correct the interference at his/her own expense.

Canada

This Class (A) digital apparatus meets all the requirements of the Canadian Interference-Causing Equipment Regulations.

Cet appareil numérique de la Classe (A) respecte toutes les exigences du Règlement sur le matériel brouilleur du Canada.

Fan Speed Control with Multiple Motors

The P266 Series Single-Phase Condenser Fan Speed Control can be used to modulate multiple identical motors in an application. Care must be taken to ensure that the combined motor amperage draw of the multiple motors being modulated does not exceed the rating of the P266 Series Control. Be aware that as the individual motor speed is reduced, the amperage draw of each motor can increase above the listed amperage rating of the motor.

Consider the following when wiring multiple motors in parallel:

- If a 12 ampere model of P266 Series Control is used with multiple external rotor motors, it is recommended that the total rated amperes (based on the motor nameplates) not exceed 9.5 amperes.
- When using three triac 8 ampere models but connecting only a single triac, it is recommended that the total rated amperes (based on the motor nameplates) not exceed 6.5 amperes.

Note: If the sum of the motor nameplate current ratings exceeds 80% of the rating of the P266 Series Control, there may be performance issues at system startup. The cause of these issues would not strictly be the current draw, but also the low inductance of the multiple motors. To ensure proper operation at system startup, always test the application prior to installation.

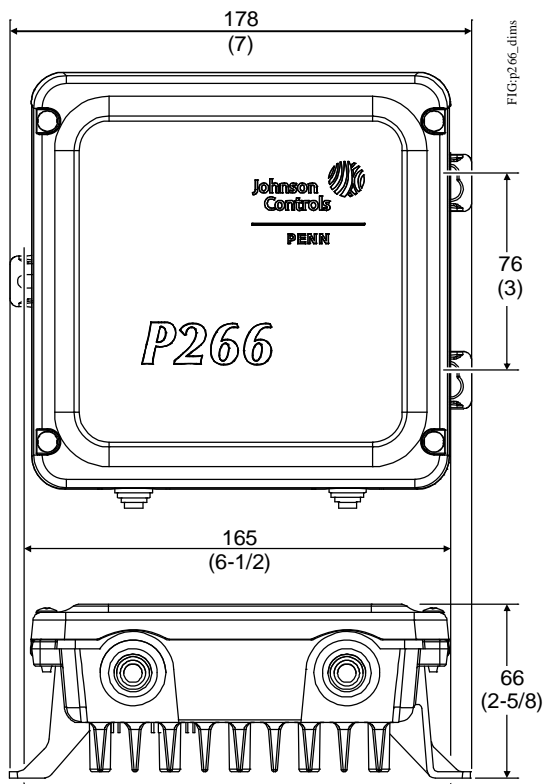

Figure 1: P266 Single-Phase Condenser Fan Speed Control Mounting Dimensions, mm (in.)

Mounting

Location Considerations

Observe these guidelines when locating and mounting a P266 Series Single-Phase Condenser Fan Speed Control:

- Ensure that the mounting surface and mounting hardware can support the control and wiring.
- Mount the P266 Series Control upright on a vertical surface with the heat sink fins oriented vertically and the conduit/electrical holes facing down.
- Ensure that air can flow through the heat sink fins and provide 10 cm (4 in.) minimum clearance around the heat sink.
- Mount the P266 Series Control in a location away from sources of excessive heat and within the specified ambient operating conditions. See [Technical Specifications](#) for ambient operating conditions.

Wiring

Refer to the model specific wiring diagram located on the interior label of the P266 Series Single-Phase Condenser Fan Speed Control, and observe these guidelines when wiring the P266 Series Control:



WARNING: Risk of Electric Shock.

Disconnect or isolate all power supplies before making electrical connections. More than one disconnect or isolation may be required to completely de-energize equipment. Contact with components carrying hazardous voltage can cause electric shock and may result in severe personal injury or death.

IMPORTANT: Do not connect supply power to the P266 Series Control before finishing wiring and checking all wiring connections. Short circuits or improperly connected wires can result in damage to the P266 Series Control and void any warranty.

IMPORTANT: Do not exceed the P266 Series Control electrical ratings. Exceeding P266 Series Control electrical ratings can result in permanent damage to the P266 Series Control and void any warranty.

IMPORTANT: Use 60/75 C copper conductors only. Make all wiring in accordance with local, national, and regional regulations.

IMPORTANT: Electrostatic discharge can damage P266 Series Control components. Use proper Electrostatic Discharge (ESD) precautions during installation and servicing to avoid damaging P266 Series Control components.

- Ensure that the wires between the P266 Series Control and the fan motor do not exceed 15 m (50 ft).
- Wires connected to the line voltage terminal block must be 3.31 mm² (12 AWG) or smaller.
- Low voltage wires must be less than 30 m (100 ft).

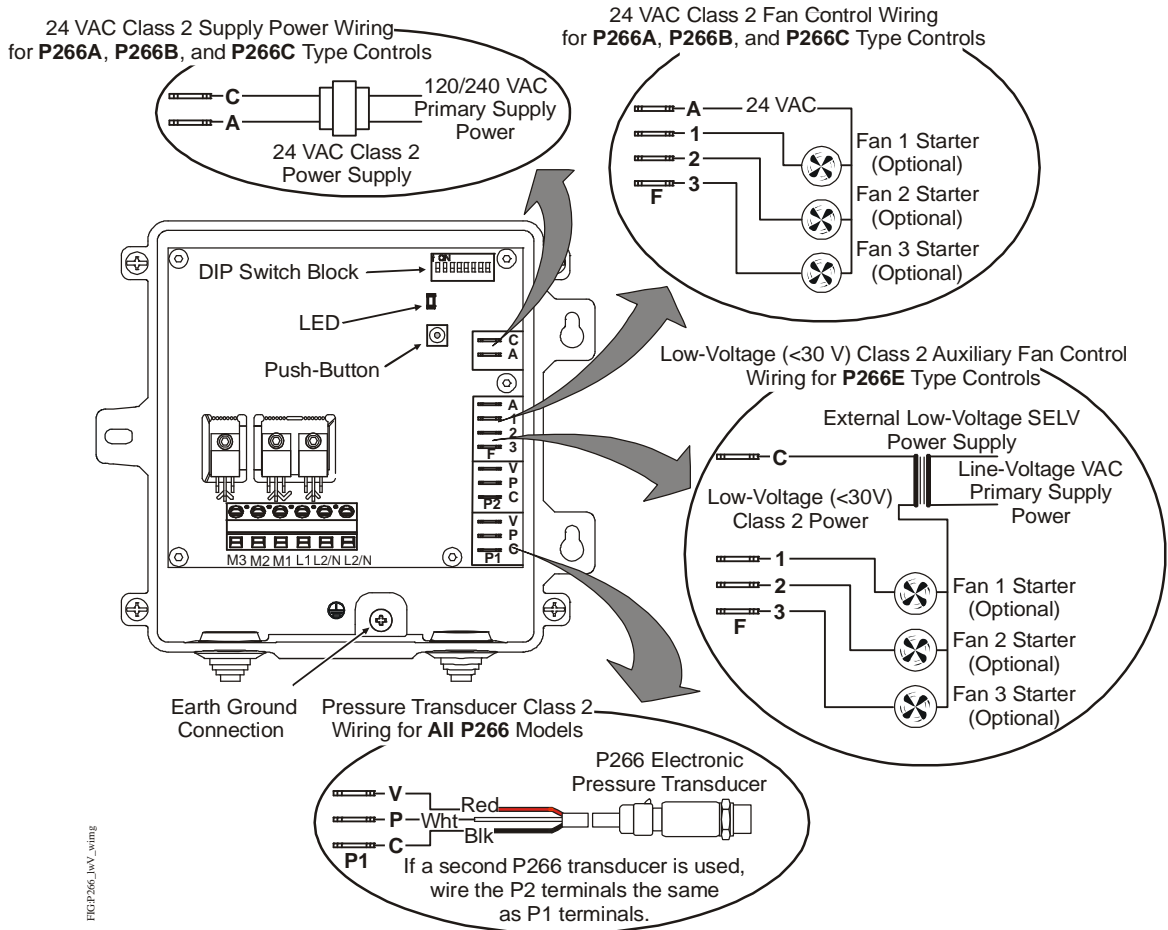

Figure 2: P266 Series Control Physical Features and Low Voltage Wiring

Low-Voltage Wiring

Figure 2 shows the P266 Series Control features under the housing cover and the low voltage wiring diagrams for the P266A, P266B, P266C, and P266E Type Control models.

High-Voltage Wiring

Figure 3 shows the high voltage wiring diagrams for the P266A, P266B, and P266C Type Control models.

Figure 4 show the high voltage wiring diagrams for the P266E Type Control models.

IMPORTANT: The L2/N terminal must be connected to line voltage in order for a P266 Series Control to comply with the FCC and IEC Class B radio frequency interference emissions limit.

Use Table 1 to determine the high voltage wiring options available for P266A, P266B, P266C, and P266E Type Control models.

Split Winding/Three Triac with LSC Wiring for P266A Type Controls (208/240 VAC Only)

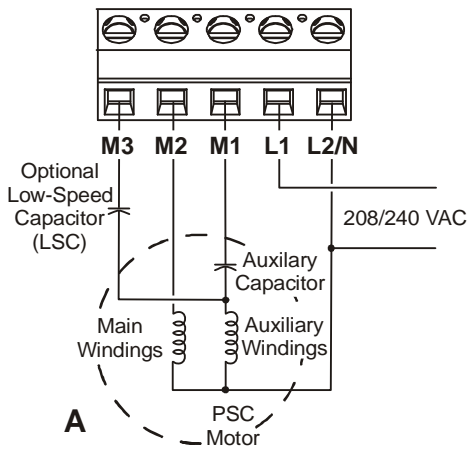

Two Triac with LSC Wiring for P266A, P266B and P266C Type Controls (208/240 VAC, 380/460 VAC, and 460/575 VAC)

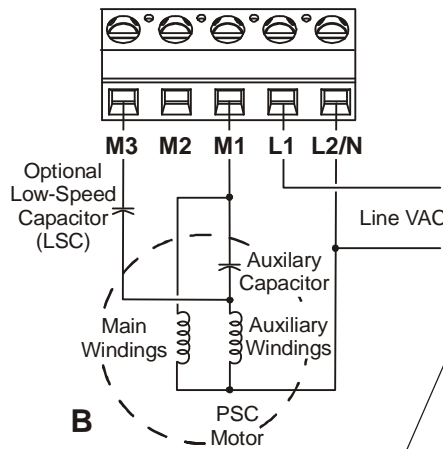

One Triac Wiring for P266A, P266B, and P266C Type Controls (208/240 VAC, 380/460 VAC, and 460/575 VAC)

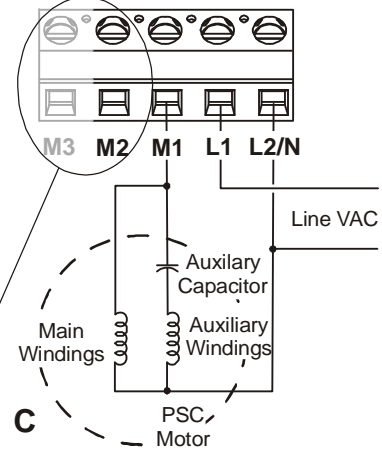

Note: Some P266A, P266B and P266C models do not have M2 or M3 Triacs.

FIG-p266_NA_HV_wiring

Figure 3: High Voltage Wiring Options for P266A, P266B, and P266C Type Controls

Split-Winding/Three Triac with LSC Wiring for P266E Type Controls (208/240 VAC Only)

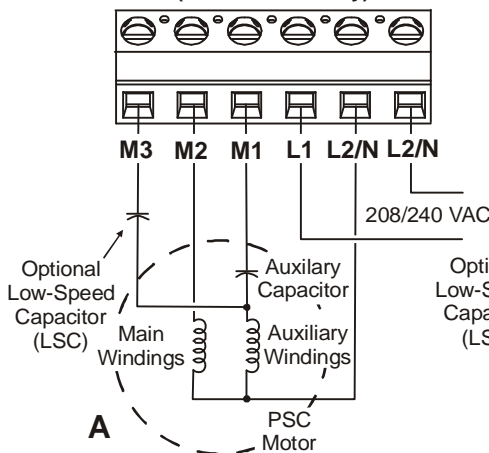

Two Triac with LSC Wiring for P266E Type Controls (208/240 VAC Only)

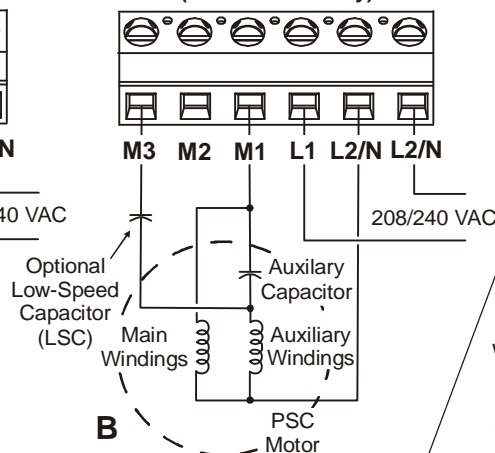

Single Triac Wiring for P266E Type Controls (208/240 VAC Only)

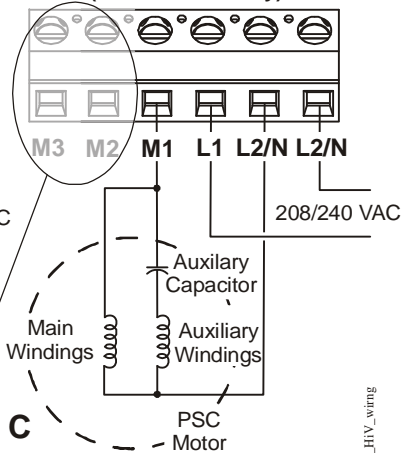

Note: The L2/N terminals are connected internally.

Note: Some P266E models do not have M2 or M3 Triacs.

FIG-p266_E_HV_wiring

Figure 4: High Voltage Wiring Options for P266E Type Controls

Table 1: Product Type High Voltage Wiring Options and Voltage Ranges

Product Type Number	Split Winding/ Three Triac with Low-Speed Capacitor	Two Triac with Low-Speed Capacitor			Single Triac		
	208/240 VAC	208/240 VAC	380/460 VAC	460/575 VAC	208/240 VAC	380/460 VAC	460/575 VAC
P266AA	See Figure 3A	See Figure 3B	--	--	See Figure 3C	--	--
P266AB	See Figure 3A	See Figure 3B	--	--	See Figure 3C	--	--
P266AC	--	--	--	--	See Figure 3C	--	--
P266AD	--	--	--	--	See Figure 3C	--	--
P266BC	--	--	--	--	--	--	See Figure 3C
P266BD	--	--	--	--	--	--	See Figure 3C
P266BG	--	--	--	See Figure 3B	--	--	See Figure 3C
P266BH	--	--	--	See Figure 3B	--	--	See Figure 3C
P266EA	See Figure 4A	See Figure 4B	--	--	See Figure 4C	--	--
P266EB	See Figure 4A	See Figure 4B	--	--	See Figure 4C	--	--
P266EC	--	--	--	--	See Figure 4C	--	--
P266ED	--	--	--	--	See Figure 4C	--	--
P266EE	--	--	--	--	See Figure 4C	--	--
P266EF	--	--	--	--	See Figure 4C	--	--
P266CH	--	--	See Figure 3B	--	--	See Figure 3C	--

Setup and Adjustments

All P266 Series Controls ship with factory set default values and mode settings. In most applications, the default values and modes do not require field adjustment.

If your P266 Series Control application requires you to change the value or mode settings, you must:

1. Calculate the new values and determine the new mode settings required for your application. (See *P266 Series Control Values and Modes*.)
2. Change the existing settings on the control to the new values and modes using the P266 Series Control setup interface. (See *Setting Values and Modes*.)

P266 Series Control Setup Interface

The P266 Series Control setup interface consists of a DIP switch block with eight binary switches, a push button, and a green LED (Figure 2). You can change the factory set default values and modes by repositioning the DIP switches and saving the new settings. The number of LED flashes (in sequence) indicates which value and/or modes that you are saving. See Table 2 for more information about LED flash sequences, values, and modes.

During normal operation, the green LED is on. When you press and hold the push button, the LED goes off for 3 seconds then flashes two times. The LED then goes off again for 3 seconds and flashes three times, and continues in this pattern until seven flashes or until you release the push button.

Each sequence of flashes indicates a value or a value and set of mode settings. Releasing the push button after the desired flash sequence saves the value and/or modes that are currently set on the DIP switch block. See Table 2 for more information.

After you complete the setup, set all of the DIP switches to the on position to lock out the push button operation.

P266 Series Control Values and Modes

P266 Series Controls have up to ten values and modes (in six flash sequences) that can be changed in the field. See Table 2 for more information about flash sequences and the associated values and modes.

Start Voltage Value

The start voltage (VAC) is the voltage delivered by the P266 Series Control to the fan motor to run the motor at minimum speed in your application.

The start voltage value is a percentage of the P266 Series Control input voltage. Use the following formula to calculate the start voltage value for your application.

$$\frac{\text{Start Voltage (VAC)}}{\text{P266 Control Input Line- Voltage (VAC)}} = \text{Start Voltage Value (\%)}$$

Low Pressure Mode

Low pressure mode determines whether the fan motor is either on (at start voltage/minimum speed) or off when the sensed pressure at the P266 Transducer is below the start pressure setpoint.

Start Pressure Value

Start pressure (psig or bar) is the pressure setpoint at which the P266 Series Control outputs the start voltage and runs the fan motor at minimum speed. Start pressure value is a function of the start pressure setpoint and the pressure range of the referenced P266 Transducer. Use the following formula to calculate the start pressure value. See Table 3 for P266 Transducer pressure ranges.

$$\frac{\text{Start Pressure Setpoint (bar or psi)}}{\text{P266 Transducer Pressure Range (bar or psi)}} \times 250 = \text{Start Pressure Value}$$

End Pressure Setpoint Value

The end pressure setpoint is the pressure (bar or psig) at which the P266 Series Control outputs the end voltage and runs the fan motor at maximum speed. End pressure value is a function of the end pressure setpoint and the total pressure range of the referenced transducer. Use the following formula to determine your application end pressure value. See Table 3 for P266 Transducer pressure ranges.

$$\frac{\text{End Pressure Setpoint (bar or psi)}}{\text{P266 Transducer Pressure Range (bar or psi)}} \times 250 = \text{End Pressure Value}$$

Split Winding Mode

Some single-phase PSC motors have split motor winding wire leads. Setting the split winding mode on enables the M2 triac to provide voltage to the main windings (and not the auxiliary windings), which increases motor efficiency.

Note: Split winding mode is available for only 240 VAC single-phase PSC motors that have split winding wire leads. Refer to the motor manufacturer installation instructions to determine if your fan motor may be wired to enable the split winding mode.

Copeland Digital Scroll™ Compressor Mode

Digital scroll compressor mode allows you to use the P266 Series Control on a system that uses a digital scroll compressor. Failure to enable the digital scroll compressor mode when using a digital scroll compressor may cause your condenser fan to oscillate.

End Voltage Mode

End voltage mode is the voltage output by the P266 Series Control (as a percentage of the full voltage) that is maintained when the monitored pressure is equal to or greater than the end pressure. The end voltage mode can be set to either 95% or 97% of the total input voltage. See Figure 5.

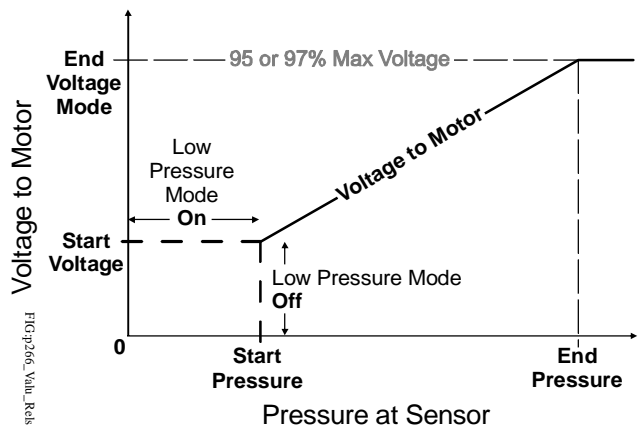

Figure 5: Relationship between P266 Series Control Variables

Low-Speed Capacitor Mode

In some fan speed applications, a (user-supplied) low-speed capacitor can be connected to the P266 Series Control M3 triac and the controlled fan motor (Figure 3 and Figure 4). The low-speed capacitor is enabled at low voltages to enhance the fan motor efficiency and performance. Set the low-speed capacitor mode to on when a low-speed capacitor is used.

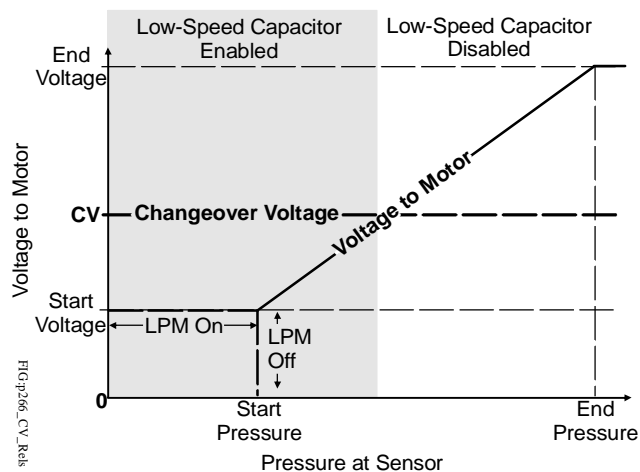

Figure 6: Low-Speed Capacitor Operation

Note: The optional low-speed capacitor should be equal in both the voltage range and the microfarad value to the auxiliary capacitor supplied by the manufacturer, but the capacitor must not exceed 15 microfarads.

Note: You must also set the changeover voltage value when a low-speed capacitor is used in your P266 Series Control application. See [Changeover Voltage Value](#) and [Determining the Changeover Voltage Value](#) for more information on setting the changeover voltage value.

Auxiliary Fan Stage Mode

You can set the P266 Series Control to cycle (on/off) up to three additional (fixed-speed) fan motors or fan stages in conjunction with the variable speed fan controlled by the P266 Series Control.

Three low voltage circuits (Figure 2) can be wired to control the auxiliary fan motor/stage starters. See Table 2 for information on setting the number of auxiliary fans used in your application.

Figure 7 shows a P266 Series Control application with one auxiliary fan operating in conjunction with the speed-controlled fan. When the condenser load exceeds the output capacity of the speed-controlled fan, the P266 Series Control powers on the auxiliary fan and shifts the speed-controlled (P266) fan to a new start pressure.

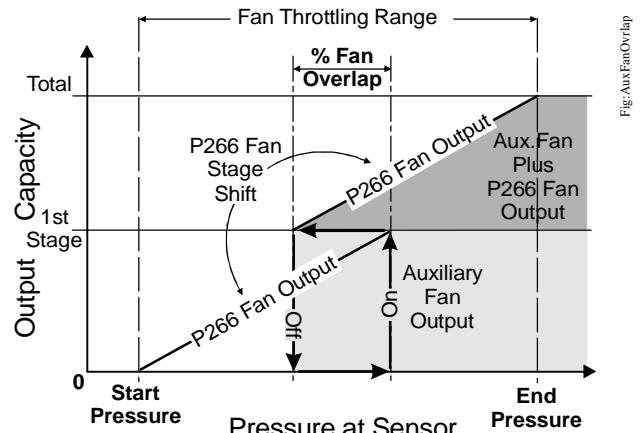

Figure 7: Speed-Controlled (P266) Fan Operating with One Auxiliary (On/Off) Fan Stage over the Entire Pressure Range

Auxiliary Fan Overlap Value

Auxiliary fan overlap value determines the pressure range overlap (as a percentage of the total pressure [throttling] range) between the fan stages set up on the P266 Series Control. The fan overlap value is equal for all auxiliary fan stages set up on the control.

Increasing the auxiliary fan overlap value decreases the (on/off) cycling rate of the auxiliary fans, and increases the pressure differential between auxiliary fan stages (which increases the pressure range of each auxiliary fan stage).

Note: If the P266 Series Control is set for no auxiliary fans, the auxiliary fan overlap value is not used. See Table 2 for information on setting the number of auxiliary fans used in your application.

Changeover Voltage Value

The changeover voltage value determines the voltage at which the P266 Series Control enables and disables the M3 triac and the low-speed capacitor (Figure 6). See [Determining the Changeover Voltage Value](#).

Setting Values and Modes

To change settings and values on a P266 Series Control:

1. Determine the operating pressure setpoints (psig or bar), voltage inputs and outputs (VAC), and the other modes of operation required for your condenser fan motor control application.
2. Convert the selected pressure setpoints (psig or bar) and voltage targets (VAC) into P266 Series Control values. See [P266 Series Control Values and Modes](#) and Table 2.
3. Position the DIP switches to set the new values and/or modes. See [Setting Up the DIP Switch Block](#).
4. Press and hold the push button until the number of LED flashes indicates the desired value or set of values and/or mode settings. Release the push button after:
 - two flashes to save the low pressure mode setting and the start voltage value
 - three flashes to save the start pressure value
 - four flashes to save the end pressure value
 - five flashes to save the split winding, end voltage, low-speed capacitor mode, and auxiliary fan stages mode settings
 - six flashes to save the auxiliary fan overlap value
 - seven flashes to save the changeover voltage value

Note: See Table 2 for more information about the values and modes that are associated with the number of LED flashes.

5. Repeat Steps 3 and 4 for the next value and/or mode you need to change.
6. After you save all of the new values and mode settings, set all of the DIP switches to the on position to lock out the push button operation.

Setting Up the DIP Switch Block

To set new values and modes on the DIP switch block:

1. Position all of the switches on the DIP switch block to the off position.

2. Position the numbered switches to on so that the total of the switch numbers (in the on position) equals the desired setup value. Start with the highest number switch that is less than the setup value. (For example, if the desired setup value is 185, position switch 128 to on first. Then position switch 32 on, followed by switch 16, switch 8, and switch 1 [$128+32+16+8+1=185$] [Figure 8]).

Mode settings require you to position only one or two switches on the DIP switch block, depending on the mode. See Table 2 for more information about the values and modes that are associated with the number of LED flashes.

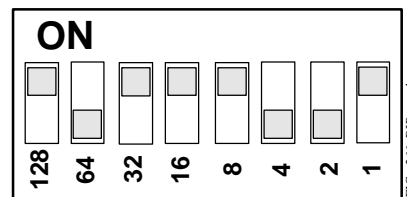

Figure 8: A DIP Switch Block with the Switches Positioned for a Setup Value of 185

IMPORTANT: All of the switches on the DIP switch block must be set to the proper positions for your application before you press and release the push button to save the values and/or mode settings. See Table 2 for more information on switch positions.

Test Voltage Mode

Test voltage mode is a setup and diagnostic tool in the P266 Series Control firmware that allows you to test the operation of a condenser fan motor at different voltage values in the field, and determine the optimal start voltage value for your P266 Series Control application.

Test voltage mode also allows you to determine and set the optimal changeover voltage value for the M3 triac in P266 Series Control applications that use a low-speed capacitor.

To use the test voltage mode, you need:

- a P266 Series Control model designed for your condenser fan application
- access to the condenser (and fan motor) controlled by your P266 Series Control
- a clamp-on ampere meter with 15 A range (to check changeover current draw when determining changeover voltage value)
- an insulated probe to hold down the push button and change the DIP switch positions

- a 24 VAC Class 2 power supply (only for P266 Series Control models that require an external 24 VAC power supply)
- a low-speed capacitor, sized for the fan motor (only for P266 Series Control applications that use a low-speed capacitor)

Note: The low-speed capacitor should be equal in both the voltage range and the microfarad value to the auxiliary capacitor of the motor manufacturer, but the low-speed capacitor must not exceed 15 microfarads.

Setting Up the Test Voltage Mode

Before you power on a P266 Series Control and enable the test voltage mode on the control:

1. Read and follow the guidelines and procedures in the [Mounting](#) and [Wiring](#) sections.
2. Mount and wire the P266 Series Control in your condenser application and observe these additional guidelines:
 - Refer to the label inside the P266 Series Control housing cover for model-specific wiring details. See [Wiring](#) for some wiring options.
 - Wire the auxiliary and main windings according to the motor manufacturer instructions and your application requirements. Split the windings (at the winding leads) and power them separately, if your application and motor allow for split-winding operation. See Figure 3 and Figure 4.
 - If your application uses an optional low-speed capacitor, wire the low-speed capacitor to the M3 triac and motor only after you have checked and recorded the current draw at maximum. See [Determining the Changeover Voltage Value](#).
 - If your P266 Series Control model requires an external 24 VAC power supply for control operation, wire that power supply to the control. (Refer to the wiring label inside the P266 Series Control cover for external power supply requirements.)
 - You do not have to connect, wire, or power the P266 Transducer, or put a load on the condenser to operate a P266 Series Control in the test voltage mode. Test voltage mode allows you to use the DIP switch to set the voltage supplied to the motor by the P266 Series Control.

3. Set up the P266 Series Control and the condenser fan motor for the intended operation by setting the required values and modes of operation for your condenser fan application. See [Setup and Adjustments](#) for procedures.

Determining the Changeover Voltage Value

In the test voltage mode, you can determine and set the changeover voltage value for P266 Series Control applications that use an optional low-speed capacitor. To determine and set the changeover voltage value:

1. Mount, wire, and set up the P266 Series Control and the condenser fan motor for operation in the test voltage mode. See [Setting Up the Test Voltage Mode](#).

Note: Do not wire the low-speed capacitor until Step 6 of this procedure.

2. Set all of the DIP switches except switch 1 to the on position; set switch 1 to off.
3. Apply line voltage power to the P266 Series Control (and the external 24 VAC power supply on required models), then within the first 30 seconds after applying power, press and release the push button three times. The LED goes off and stays off, and the fan motor accelerates to maximum speed (at 95 or 97% of maximum voltage) and stays at the maximum voltage for up to 5 minutes.
4. At maximum voltage, use the clamp-on ampere meter to check the current draw (in amperes) of the fan motor auxiliary windings, and record the auxiliary windings current draw for the motor at maximum voltage.
5. Disconnect line voltage power to the P266 Series Control (and the external 24 VAC power supply on required models).
6. Wire the low-speed capacitor to the M3 triac and the motor auxiliary windings. (See Figure 3 and Figure 4 for M3 triac wiring options.)
7. Set all of the DIP switches except switches 8 and 32 to the off position; set switches 8 and 32 to the on position. ($8 + 32 = 40\%$ of maximum voltage value.)
8. Apply line voltage power to the P266 Series Control (and the external 24 VAC power supply on required models), then within the first 30 seconds after applying power, press and release the push button three times. The LED goes off and stays off, and the fan motor accelerates to the speed at 40% of the maximum voltage (for up to 5 minutes).

9. At 40% of maximum voltage, use the clamp-on ampere meter to check the current draw (in amperes) of the fan motor auxiliary windings connected to both capacitors, and record the current draw for the auxiliary winding at 40% voltage.
10. Repeat Step 7 but increase the percent voltage value by 8%, then repeat Step 8, Step 9, and Step 10 at the increased voltage values until the current draw equals the (maximum voltage) current draw recorded in Step 4.

Note: If the motor stops or does not run smoothly, reduce the voltage value on the DIP switches by 4% and test the motor operation.

11. The DIP switch voltage value is now equal to the highest voltage of the low-speed mode or the changeover voltage value.
12. Press and hold the push button until the LED flashes 3 times, then release the push button. The changeover voltage value is set and saved on the P266 Series Control.

Note: If you want to also determine and set the start voltage value for your P266 Series Control and motor, you can go directly to Step 3 of the [Determining the Start Voltage Value](#) procedure.

13. Disconnect power to the P266 Series Control and set all of the DIP switches to the on position to lock out the push button operation.
14. Reconnect power to the P266 Series Control to resume normal motor speed control.

Determining the Start Voltage Value

In the test voltage mode, you can also determine and set the start voltage value for the P266 Series Control application.







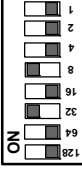
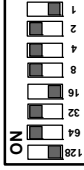
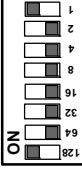
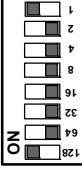

To determine and set the start voltage value:

1. Mount, wire, and set up the P266 Series Control and the condenser fan motor for operation in the Test Voltage mode. See [Setting Up the Test Voltage Mode](#).

Note: If your application uses split winding mode and low-speed capacitor mode, wire the split windings and low-speed capacitor according to your application requirements.

2. Apply line voltage power to the P266 Series Control (and the external 24 VAC power supply on required models), then within the first 30 seconds after applying power, press and release the push button three times. The LED goes off and stays off.
3. Position the DIP switches so that the total value of the switches positioned on is equal to a percentage value equal to or slightly higher than your estimated start voltage value. (For example, if you estimate the start voltage of the motor to be 25% of the total voltage, position switches 16, 8, 4, and 2 to on. $16 + 8 + 4 + 2 = 30\%$, which is slightly higher than your 25% estimate.) The fan motor accelerates to the speed at 30% of maximum voltage and stays at that speed.
4. Observe the fan motor operation and determine if the applied start voltage runs the motor at the desired start speed:
 - If the start speed and motor operation meet your application requirements, go to Step 5.
 - If the start speed or operation does not meet your application requirements, return to Step 3 and set a new estimated start voltage value to generate the desired motor start speed.
5. When your motor is running at the desired start speed (start voltage value), press and hold the push button until the LED flashes 2 times in succession, then release the push button. The start voltage value is set and saved on the P266 Series Control.
6. Disconnect power to the P266 Series Control and set all of the DIP switches to the on position to lock out the push button operation.
7. Reconnect power to the P266 Series Control to resume normal motor speed control.

Table 2: LED Flash Sequences, Setup Values, Mode Settings on DIP Switch Block and Default Values and Mode Settings Example

Release Push Button After...	Value/Mode Name (Binary Switch Number)	Value Range/Mode Settings (Example Default Settings)	Switch Number and Position Description of Value/Setting	DIP Switch Block Example Default Settings
Two Flashes	Low Speed Mode (Switch 128)	Settings: ON or Off (Default Setting: Off)	Switch 128 Off = No voltage to motor when sensed pressure is below start pressure. Switch 128 ON = Start voltage to motor when sensed pressure is at or below start pressure.	
	Start Voltage Value (Switches 1 to 64)	Value Range: 10 to 90 (Default Value: 40)	Position Switches 1 to 64 ON or Off so that the sum of the switches set to ON equals the Start Voltage Value.	
Three Flashes	Start Pressure Value (Switches 1 to 128)	Value Range: 10 to 230 (Default Value: 110)	Position Switches 1 to 128 ON or Off so that the sum of the switches set to ON equals the Start Pressure Value.	
	End Pressure Value (Switches 1 to 128)	Value Range: [Start Pressure + 8] to 240 (Default Value: 129)	Position the Switches 1 to 128 ON or Off so that the sum of the switches set to ON equals the End Pressure Value.	
Five Flashes (Switches 64 and 128 Off)	Split Winding Mode (Switch 32)	Settings: ON or Off (Default Setting: Off)	Switch 32 ON = M2 Triac enabled to power split windings. Switch 32 Off = M2 Triac is disabled.	
	End Voltage Mode (Switch 16)	Settings: ON or Off (Default Setting: Off)	Switch 16 ON = Provides 95% of P266 input voltage to motor. Switch 16 Off = Provides 97% of P266 input voltage to motor.	
	Digital Scroll Compressor Algorithm (Switch 8)	Settings: ON or Off (Default Setting: Off)	Switch 8 ON = Digital Scroll algorithm enabled. Switch 8 Off = Digital Scroll algorithm disabled.	
	Low Speed Capacitor Mode (Switch 4)	Settings: ON or Off (Default Setting: Off)	Switch 4 ON = Low-speed capacitor is available. Switch 4 Off = Low-speed capacitor is not available.	
	Number of Auxiliary Fan Stages (Switches 1 and 2)	Settings: ON or Off (Default Setting: Off - Off)	Position switches 1-Off and 2-Off for no auxiliary fans. Position switches 1-On and 2-Off for auxiliary fan 1. Position switches 1-Off and 2-On for auxiliary fans 1 and 2. Position switches 1-On and 2-On for auxiliary fan 1, 2, and 3.	
	Auxiliary Fan Overlap (Switches 1 to 64)	Value Range: 1 to 90 (Default Value: 10)	Position Switches 1 to 64 ON or Off so that the sum of the switches set to ON equals the Auxiliary Fan Overlap Value.	
Six Flashes (Switch 128 Off)	Auxiliary Fan Overlap (Switches 1 to 64)	Value Range: 1 to 90 (Default Value: 10)	Position Switches 1 to 64 ON or Off so that the sum of the switches set to ON equals the Auxiliary Fan Overlap Value.	
Seven Flashes (Switch 128 Off)	Changeover Voltage Value (Switch 1 to 64)	Value Range: 10 to 80 (Default Value: 60)	Position Switches 1 to 64 ON or Off so that the sum of the switches set to ON equals the Changeover Voltage value.	

P266 Electronic Pressure Transducers

P266 Series Controls are designed to reference either one or two Johnson Controls P266 Electronic Pressure Transducers to monitor condenser pressure.

P266 Transducers are specialized versions of the P499 Series Electronic Pressure Transducers designed for use with P266 Series Controls. See Table 3 for the available P266 Transducer models.

Note: On P266 Series Control applications that use two P266 Transducers, the P266 Series Control always references the transducer that is sensing the highest pressure.

IMPORTANT: When two P266 Transducers are connected to a P266 Series Control, the transducers must be the same model (product code number). Failure to connect the same P266 Transducer models to the P266 Series Control can result in erratic control behavior.

Refer to the *P499 Series Electronic Pressure Transducers Product/Technical Bulletin (LIT-12011190)* for information on installing P266 Transducers.

Table 3: P266SNR Electronic Pressure Transducers

Product Code Number	Description
P266SNR-1C	Electronic Pressure Transducer: 0 to 35 bar (0 to 508 psig) Total Range with a 1/4 in. SAE Female Flare Connection and a 2 m (3.1 ft) Cable
P266SNR-2C	Electronic Pressure Transducer: 0 to 52 bar (0 to 754 psig) Total Range with a 1/4 in. SAE Female Flare Connection and a 2 m (3.1 ft) Cable

Technical Specifications

P266xxx-x Series Single-Phase Condenser Fan Speed Controls (Part 1 of 2)

Input Supply Power	208/240 VAC 50/60 Hz, 380/460 VAC 50/60 Hz, or 460/575 VAC 50/60 Hz, Depending on the Model (Refer to the Label inside the P266 Series Control Housing Cover for Rated Voltage Range and Model-Specific Wiring Diagram)
Short Circuit Current Rating	Suitable for Use on a Circuit Capable of Delivering Not More Than 5,000 rms Symmetrical Amperes, 600 Volts Maximum When Protected by Class H Fuses
Low-Voltage Power Supply	P266A, P266B, and P266C Types: External 24 VAC Class 2, 20 VA Supply Transformer P266E Types: Low Voltage Power for P266 Series Control is Provided by an Onboard Transformer Note: When auxiliary fan starters are connected to P266E type controls, you must provide an external Safety Extra-Low Voltage (SELV) AC supply to power the fan starters.
Ambient Operating Conditions	Temperature: -40 to 60°C (-40 to 140°F) Humidity: Up to 95% RH Non-condensing; Maximum Dew Point 29°C (85°F)
Ambient Shipping and Storage Conditions	Temperature: -40 to 85°C (-40 to 185°F) Humidity: Up to 95% RH Non-condensing; Maximum Dew Point 29°C (85°F)
Low Voltage Connections	1/4 in. Quick-Connect Terminals, 30 m (100 ft) Maximum Wiring Runs
Input Transducer	P266SNR-x Pressure Transducer: 5 VDC for 0.5 to 4.5 VDC Ratiometric Analog Signal
Enclosure Type	NEMA 3R, IP54
Case Construction	Aluminum Die Casting
Cover Construction	UV Stabilized Polycarbonate
Dimensions (H x W x D)	159 x 177 x 70 mm (6-1/4 x 7 x 2-3/4 in.)
Weight	Heaviest Model Weight: 1.0 kg (2.2 lb) Approximate Shipping Weight: 1.2 kg (2.6 lb)

P266xxx-x Series Single-Phase Condenser Fan Speed Controls (Part 2 of 2)

	<p>Compliance</p> <p>North America: cULus, File E244421; FCC Compliant to CFR47, Part 15, Subpart B, Class A Industry Canada (IC) Compliant to Canadian ICES-003, Class A Limits</p>
	<p>Europe: CE Mark – Johnson Controls, Inc., declares that this product is in compliance with the essential requirements and other relevant provisions of the EMC Directive 2004/108/EC and the Low Voltage Directive 2006/95/EC.</p>
	<p>Australia: C-Tick Compliant (N1813)</p>

The performance specifications are nominal and conform to acceptable industry standards. For application at conditions beyond these specifications, contact Johnson Controls Refrigeration Application Engineering at 1-800-275-5676 or 1-414-524-5535. Johnson Controls, Inc. shall not be liable for damages resulting from misapplication or misuse of its products.



Building Efficiency

507 E. Michigan Street, Milwaukee, WI 53202

© Johnson Controls and PENN are registered trademarks of Johnson Controls, Inc. in the United States of America and/or other countries. All other trademarks used herein are the property of their respective owners. © Copyright 2012 by Johnson Controls, Inc. All rights reserved.