



model 7261-7271

AXION MSR™ Pedestal Mount Eye/Face Wash

FEATURES & BENEFITS

CONSTRUCTION

1-1/4" IPS Schedule 40 hot-dipped galvanized steel pipe and fittings along with powder-coated cast-iron 9" (22.9 cm) diameter floor flange provide corrosion resistance in a long lasting product.

QUALITY CONTROL

Eye/face wash and valve assembly are pre-built and fully water/pressure tested to ensure no leaks and proper function which ultimately reduces installation time.

BOWL

The 11" (27.9 cm) round green ABS plastic receptor is resistant to damage from alkalis

VALVE

Valve is designed to make the flushing of fluid occur with the push of a stainless steel flag, and is equipped with a stainless steel ball and stem to provide added protection against corrosion and breakage.

STRAINERS/FILTERS

Chrome-plated brass in-line 50 x 50 mesh water strainer prevents debris from reaching the eyewash so the unit stays functioning at its best. Strainer is easily serviceable.

EYE/FACE WASH

AXION MSR™ eye/face wash head (patent pending) uses an inverted directional laminar flow to sweep contaminants away from the vulnerable nasal cavity.



SPECIFICATIONS

Model 7261-7271 pedestal eye/face wash shall include a green ABS plastic 11" (27.9 cm) bowl, an AXION MSR™ eye/face wash head shall feature inverted directional laminar flow which achieves zero vertical velocity supplied by an integral flow control, chrome-plated brass stay-open ball valve equipped with stainless steel ball and stem, and chrome-plated brass in-line 50 x 50 mesh water strainer. Unit shall also include 1-1/4" Schedule 40 hot-dipped galvanized steel pipe and fittings along with powder-coated cast-iron 9" (22.9 cm) diameter floor flange, yellow plastic pop-off dust cover for eyewash head, universal sign, 1/2" IPS inlet, and 1-1/4" IPS waste.

OPTIONS

- Test Tag: SP170 is a green waterproof test card with space for date and initials of inspector. Used to record weekly testing of emergency equipment.
- Foot Treadle: Model SP220 foot control assembly, including powder-coated aluminum treadle for hands free activation of eyewash.
- Instantaneous Water Heater: Model TWBS.EW.H, prepackaged instantaneous electrical water heater, 480 VAC/3 phase/20 KW, fully engineered and tested system with fail-safe features to produce up to 6 gpm (22.7 L) tempered water for eye washes.
- Dust Cover: Model 9102 is a stainless steel cover that protects the eyewash heads as well as the bowl. Pushing the stainless steel flag will activate the unit while raising the dust cover. (Picture shows cover mounted to an eyewash.)

To see all options for this model, visit www.hawsc.com

APPLICATIONS

Where the eyes of any person may be exposed to injurious or corrosive materials, suitable facilities for quick flushing and cleansing of the eyes must be provided within the work area for immediate emergency use. Emergency eyewash facilities shall be in unobstructed and accessible locations that require no more than 10 seconds for the injured person to reach. Model 7261-7271 is certified by CSA to meet the ANSI Z358.1 Standard for Emergency Eyewash and Shower Equipment.



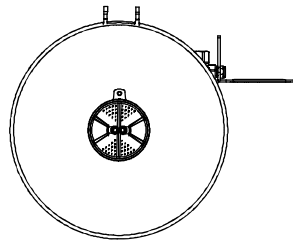

TOP VIEW

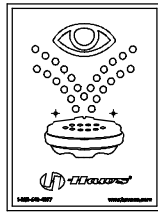

SIGN IS TO BE POSITIONED SUCH THAT IT IS VISIBLE WITHIN THE AREA SERVED BY THE EYEWASH

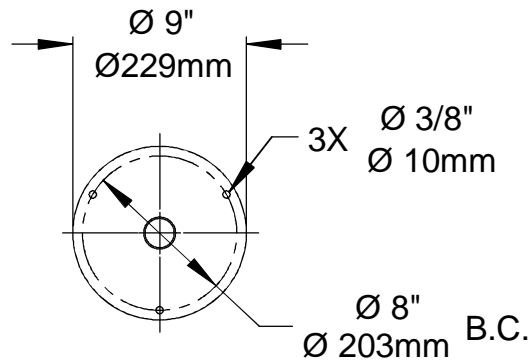

MOUNTING DETAIL

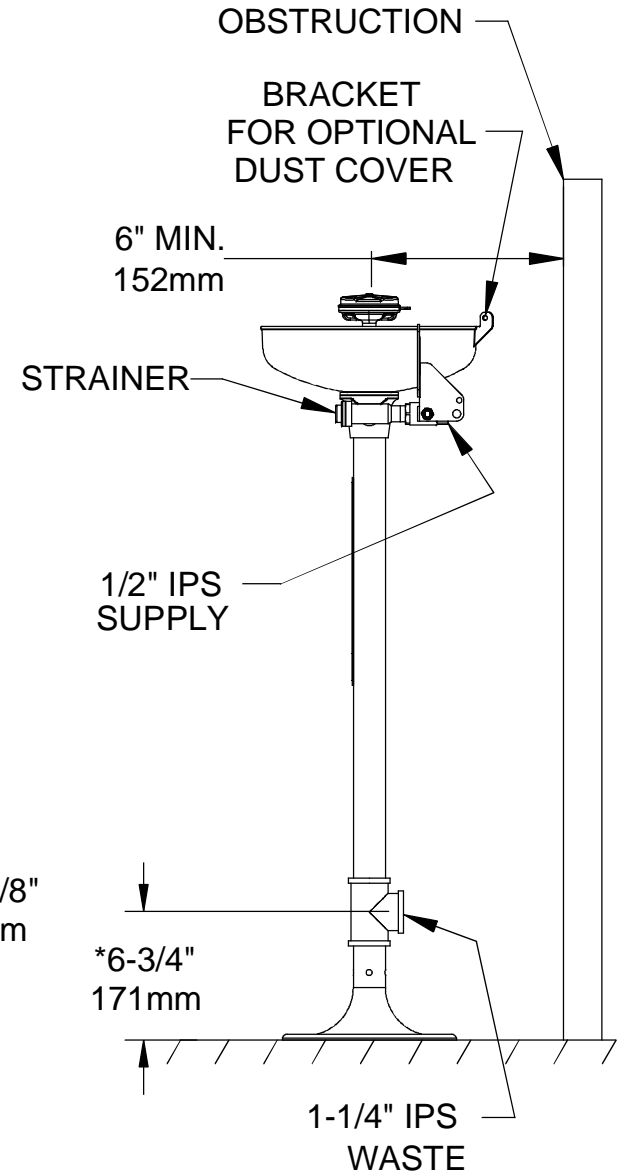
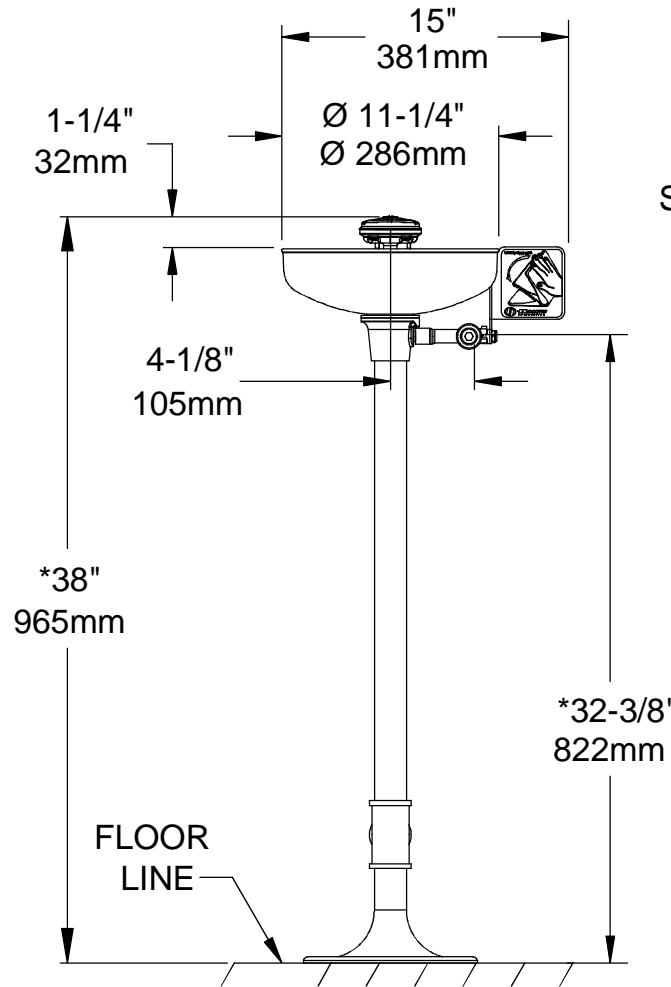

NOTES:

- TO COMPLY WITH ANSI Z358.1-2009 FOR EMERGENCY EYEWASH AND EYE/FACE WASH:
 - UNIT SHALL BE INSTALLED IN ACCORDANCE WITH MANUFACTURER'S INSTRUCTIONS AND ACCEPTABLE PLUMBING PRACTICES.
 - EYEWASH OR EYE/FACE WASH SHALL BE POSITIONED WITH NOZZLES NOT LESS THAN 83.8 CM (33IN.) AND NO GREATER THAN 114.3 CM (45 IN.) FROM SURFACE ON WHICH USER STANDS AND 15.3 CM (6 IN.) MINIMUM FROM WALL OR NEAREST OBSTRUCTION.
- *THESE DIMENSIONS MAY VARY $\pm 1/2"$ [12.7mm]

		1455 KLEPPE LANE SPARKS, NEVADA 89431 (775) 359-4712 FAX (755) 359-7424 E-MAIL: HAWS@HAWSO.COM WEBSITE: WWW.HAWSO.COM	
		ECN NO. REVISED PER BY: ECN: 4910 HM MODEL(S) 7261-7271	PART NUMBER 002080043.D DRAWING NO. REV 09398A00 18
DRAWN: C.J.L. DATE: 04/92 APPROVED:	DATE:	SCALE: 1:1 DRAWING TYPE: INSTALLATION	SIZE: A SHEET 1 OF 1