



model 7433FP

Freeze Protected Wall Mount Eyewash

FEATURES & BENEFITS

QUALITY CONTROL

Eyewash and valve assembly is pre-built and fully water and pressure tested to ensure no leaks and proper function for reduced installation time and added peace of mind. Unit also ships with pre-assembled cast-aluminum wall bracket to assist with the installation process.

BOWL

The 11" (27.9 cm) round stainless steel receptor is supplied with a No. 2L bright finish on its exterior

VALVES

Valve is designed so the full flow of fluid remains on with a simple push of a stainless steel flag. Unit also comes equipped with a stainless steel ball and stem to provide added protection against corrosion and breakage. Self-draining valve assembly is designed for installation behind the mounting wall with a maximum wall thickness of 15" (38.1 cm), in a non-freezing environment, so the unit maintains full emergency capability in freezing conditions.

MOUNTING

Wall-mounted design makes for a space efficient piece of emergency equipment with numerous installation possibilities.

FLOW CONTROLS

ABS designed plastic anti-surge Soft-Flo heads feature built-in 1.2 gpm (4.54 L) self-regulating flow controls keeping a continuous flow of water throughout the cleansing process. Unit is also equipped with green polyethylene plastic dust covers that release with water pressure to maintain an optimal functioning product.



SPECIFICATIONS

Model 7433FP freeze protected wall-mounted eyewash shall include a stainless steel 11" (27.9 cm) round bowl, stainless steel eyewash yoke assembly with Soft-Flo ABS plastic eyewash anti-surge heads with integral flow controls and dust covers, self-draining valve, and brass stay-open ball valve equipped with stainless steel ball and stem, and stem extension. Unit to be used with a maximum wall thickness of 15" (38.1 cm) and shall include chromate protective cast-aluminum wall bracket, universal sign, 1/2" IPS inlet, and 1-1/4" IPS outlet.

OPTIONS

- Test Tag: SP170 is a green waterproof test card with space for date and initials of inspector. Used to record weekly testing of emergency equipment.
- Instantaneous Water Heater: Model TWBS.EW.H, prepackaged instantaneous electrical water heater, 480 VAC/3 phase/20 KW, fully engineered and tested system with fail-safe features to produce up to 6 gpm (22.7 L) tempered water for eye washes.
- Emergency Alarm System : Model 9001.5, 1/2" 120 VAC emergency alarm and light system. Buzzer and flashing light are activated by a 1/2" IPS double pole, double throw flow switch.
- Thermostatic Mixing Valve: Model 9201EFE AXION® Emergency Tempering Valve thermostatically mixes hot and cold water to provide a safe fluid supply for a single emergency eye/face wash, with a flow rate of 12 gpm (38.8 L).

To see all options for this model, visit www.hawasco.com

APPLICATIONS

Where the body of any person may be exposed to injurious or corrosive materials, suitable facilities for quick drenching and cleansing of the body shall be provided within the work area for immediate emergency use. Emergency deluge showers shall be in unobstructed and accessible locations that require no more than 10 seconds for the injured person to reach. Model 7433FP is certified by CSA to meet the ANSI Z358.1 Standard for Emergency Eyewash and Shower Equipment.



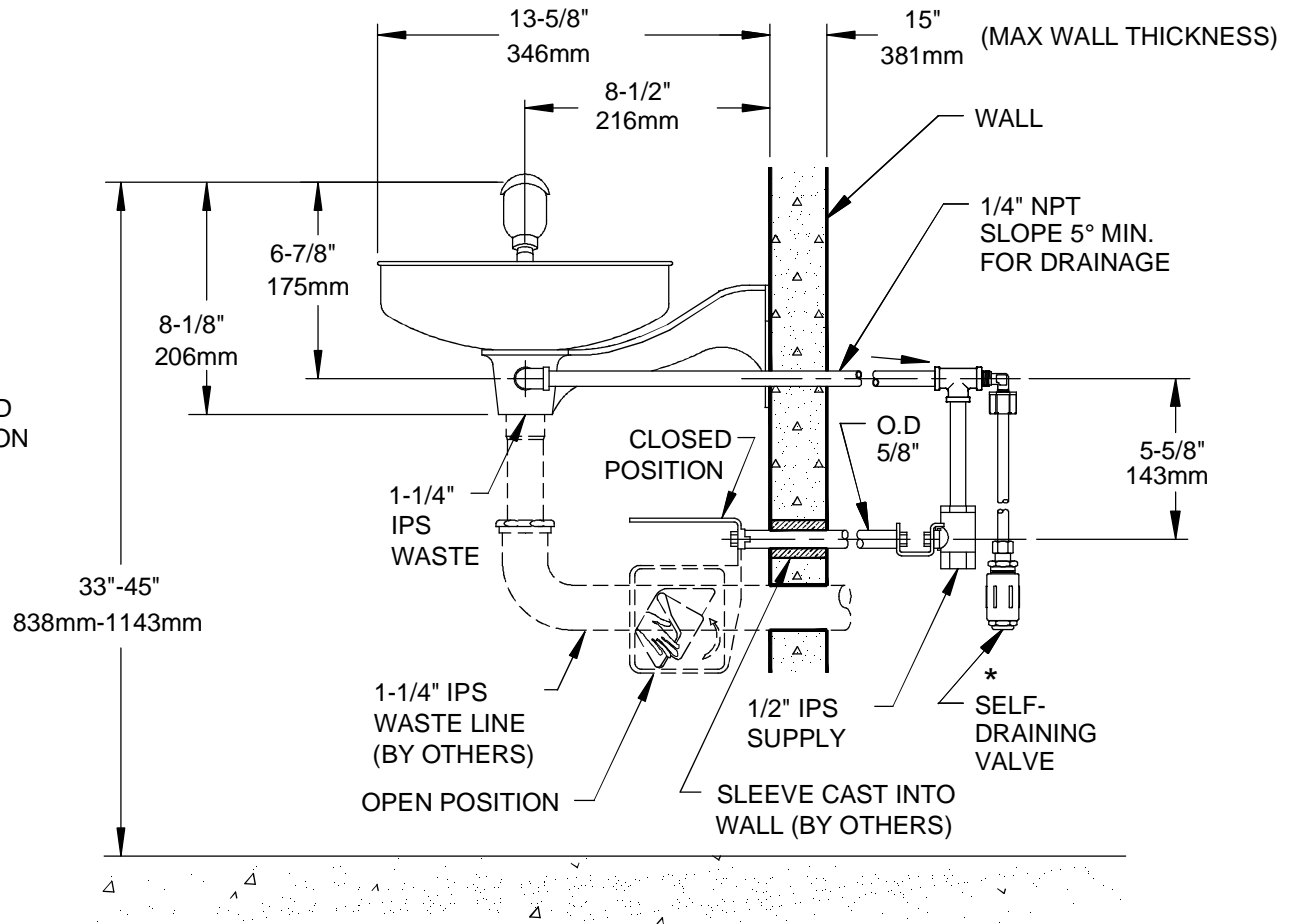
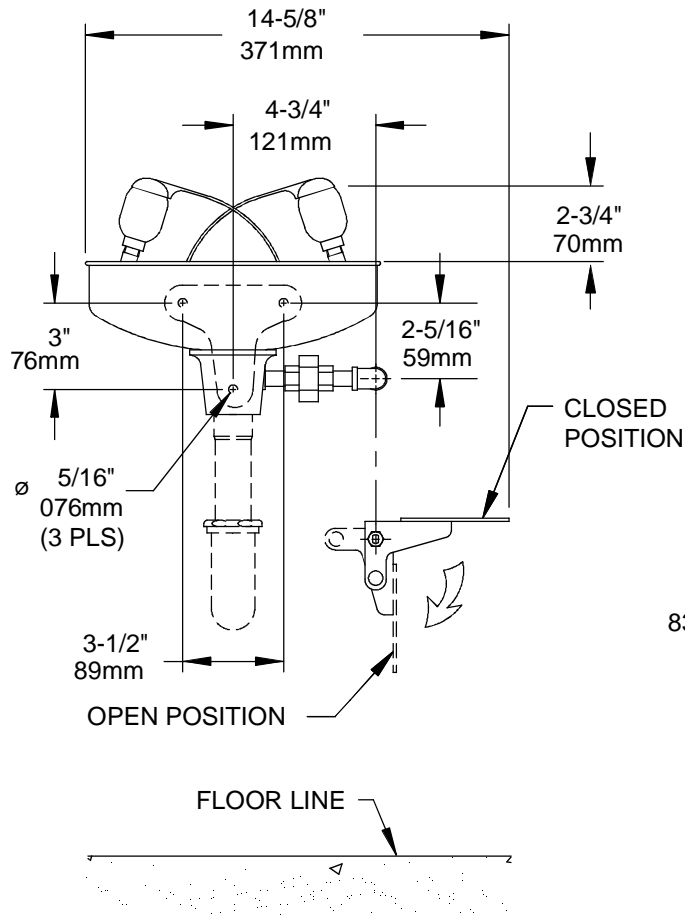

* VALVE IS SELF-DRAINING, THUS PERMITS STANDING WATER TO DRAIN AFTER EACH USE PREVENTING FREEZE-UPS. PROPER PROVISIONS MUST BE MADE FOR DRAINAGE.

NOTES:

- TO COMPLY WITH ANSI Z358.1-2009 FOR EMERGENCY EYEWASH OR EYE/FACE WASH:
 - UNIT SHALL BE INSTALLED IN ACCORDANCE WITH MANUFACTURER'S INSTRUCTIONS AND ACCEPTABLE PLUMBING PRACTICES.
 - EYEWASH OR EYE/FACE WASH SHALL BE POSITIONED WITH NOZZLES NOT LESS THAN 83.8 CM (33 IN.) AND NO GREATER THAN 114.3 CM (45 IN.) FROM SURFACE ON WHICH USER STANDS AND 15.3 CM (6 IN.) MINIMUM FROM WALL OR NEAREST OBSTRUCTION.
- DIMENSIONS MAY VARY BY ± 1/2 [13].

		1455 KLEPPE LANE SPARKS, NEVADA 89431 (775) 359-4712 FAX (775) 359-7424 E-MAIL: HAWS@HAWSCO.COM WEBSITE: WWW.HAWSCO.COM	
		ECN NO. REVISED PER BY: MODEL(S) ECN: 4744 HM	PART NUMBER 0002080048.D
DRAWN: TRF DATE: 05/16/91	DATE: CHK'D:	7433P EYEWASH, FREEZE RESISTANT	
APPROVED:	DATE:	SCALE: 1:7	DRAWING TYPE: INSTALLATION
		SIZE: A	SHEET 1 OF 1