



model 7360BTWC

AXION MSR™ Barrier-Free Eye/Face Wash

FEATURES & BENEFITS

QUALITY CONTROL

Eye/face wash and valve assembly is pre-built and fully water/pressure tested to ensure no leaks and proper function which ultimately reduces installation time and gives the end contractor an added peace of mind. Unit also ships with pre-assembled cast-aluminum wall bracket to assist in the installation process.

BOWL

The 11" (27.9 cm) round stainless steel receptor is supplied with a No. 2L bright finish on its exterior

VALVE

Valve is designed to make the flushing of fluid occur with the push of a stainless steel flag, and is equipped with a stainless steel ball and stem to provide added protection against corrosion and breakage.

STRAINERS/FILTERS

Chrome-plated brass in-line 50 x 50 mesh water strainer prevents debris from reaching the eyewash so the unit stays functioning at its best. Strainer is easily serviceable.

EYE/FACE WASH

AXION MSR™ eye/face wash head (patent pending) uses an inverted directional laminar flow to sweep contaminants away from the vulnerable nasal cavity.

OPTIONS

- ❑ Test Tag: SP170 is a green waterproof test card with space for date and initials of inspector. Used to record weekly testing of emergency equipment.
- ❑ Dust Cover: Model 9102 is a stainless steel cover that protects the eyewash heads as well as the bowl. Pushing the stainless steel flag will activate the unit while raising the dust cover. (Picture shows cover mounted to an eyewash.)
- ❑ Emergency Body Spray Kit: Model 8901RFK, body spray unit with ABS plastic head, stay open squeeze lever valve, 8 foot (243.8 cm) hose, and installation kit.
- ❑ Emergency Alarm System : Model 9001.5, 1/2" 120 VAC emergency alarm and light system. Buzzer and flashing light are activated by a 1/2" IPS double pole, double throw flow switch.

To see all options for this model, visit www.hawesco.com



SPECIFICATIONS

Model 7360BTWC barrier-free wall mounted eye/face wash shall include a stainless steel 11" (27.9 cm) round bowl, an AXION MSR™ eye/face wash head shall feature inverted directional laminar flow which achieves zero vertical velocity supplied by an integral flow control, wheelchair accessibility, chrome-plated brass stay-open ball valve equipped with stainless steel ball and stem, chrome-plated brass in-line 50 x 50 mesh water strainer, and chrome-plated brass trap and tailpiece. Unit shall also include 16 gauge stainless steel wall bracket, universal sign, 1/2" IPS inlet, and 1-1/4" IPS waste.

APPLICATIONS

Where the eyes and face of any person may be exposed to injurious or corrosive materials, suitable facilities for quick flushing of the eyes and face be provided within the work area for immediate emergency use. Emergency eye/face wash facilities shall be in unobstructed and accessible locations that require no more than 10 seconds for the injured person to reach. Model 7360BTWC is certified by CSA to meet the ANSI Z358.1 Standard for Emergency Eyewash and Shower Equipment.



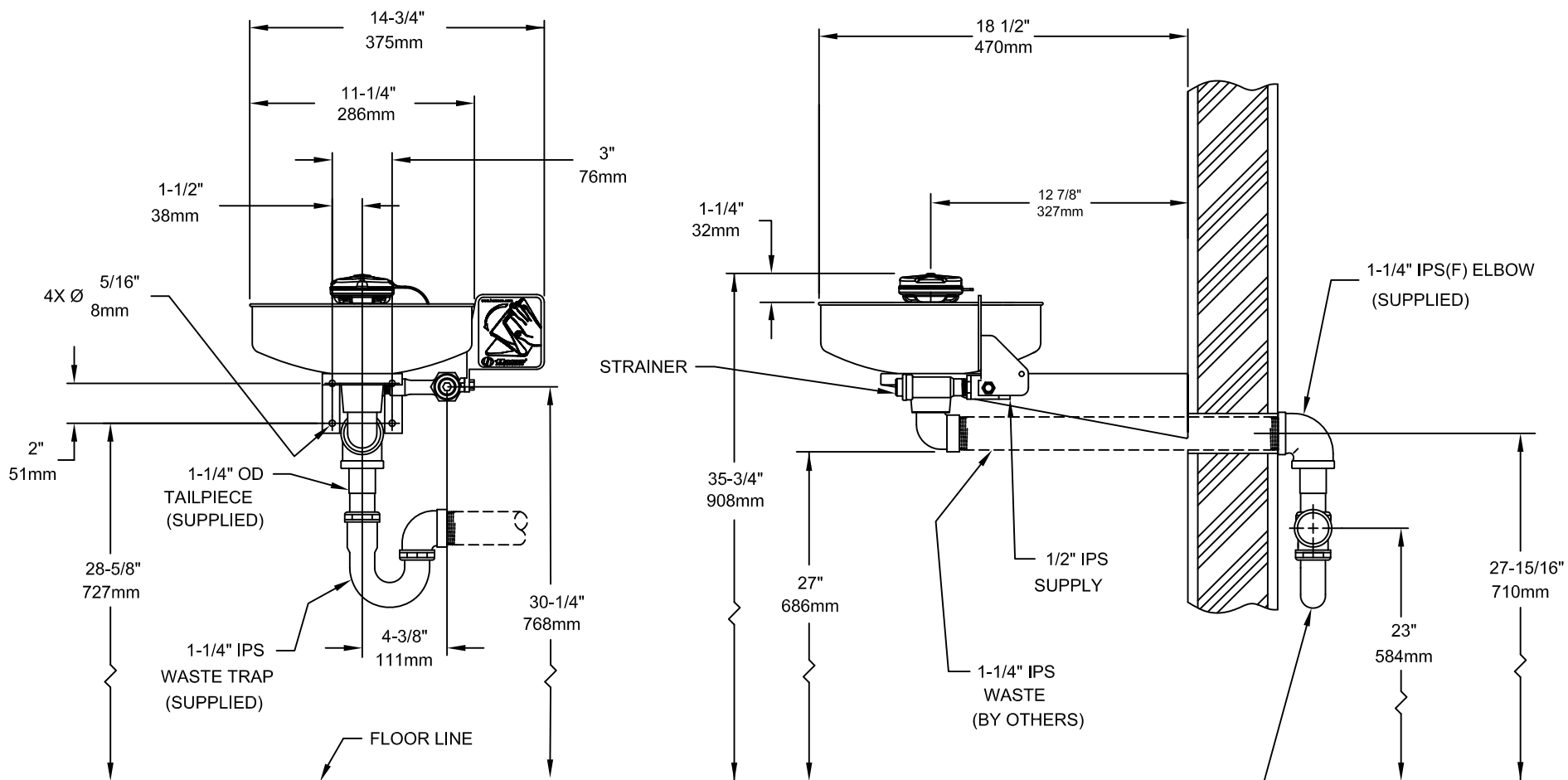

SEE SHT. 2 FOR ALTERNATE INSTALLATIONS

TRAP MUST BE ACCESSIBLE

NOTES:

- TO COMPLY WITH ANSI Z358.1-2009 FOR EMERGENCY EYEWASH OR EYE/FACE WASH AND SHOWER EQUIPMENT:
 - UNIT SHALL BE INSTALLED IN ACCORDANCE WITH MANUFACTURER'S INSTRUCTIONS AND ACCEPTABLE PLUMBING PRACTICES.
 - EYEWASH OR EYE/FACE WASH SHALL BE POSITIONED WITH NOZZLES NOT LESS THEN 83.8 CM (33 IN.) AND NO GREATER THAN 114.3 CM (45 IN.) FROM SURFACE ON WHICH USER STANDS AND 15.3 CM (6 IN.) MINIMUM FROM WALL OR NEAREST OBSTRUCTION.
- DIMENSIONS MAY VARY ±1/2" [12.7mm].

		1455 KLEPPE LANE SPARKS, NEVADA 89431 (775) 359-4712 FAX (775) 359-7424 E-MAIL: HAWS@HAWS.CO.COM WEBSITE: WWW.HAWS.CO.COM	
		ECN NO.: DRAWN: FV APPROVED:	REVISED PER: ECN: 4639 DATE: 03/98 DATE:
PART NUMBER: 0002080039.D DRAWING NUMBER: 13498A00		REV: 8	SIZE: A SHEET 1 OF 2

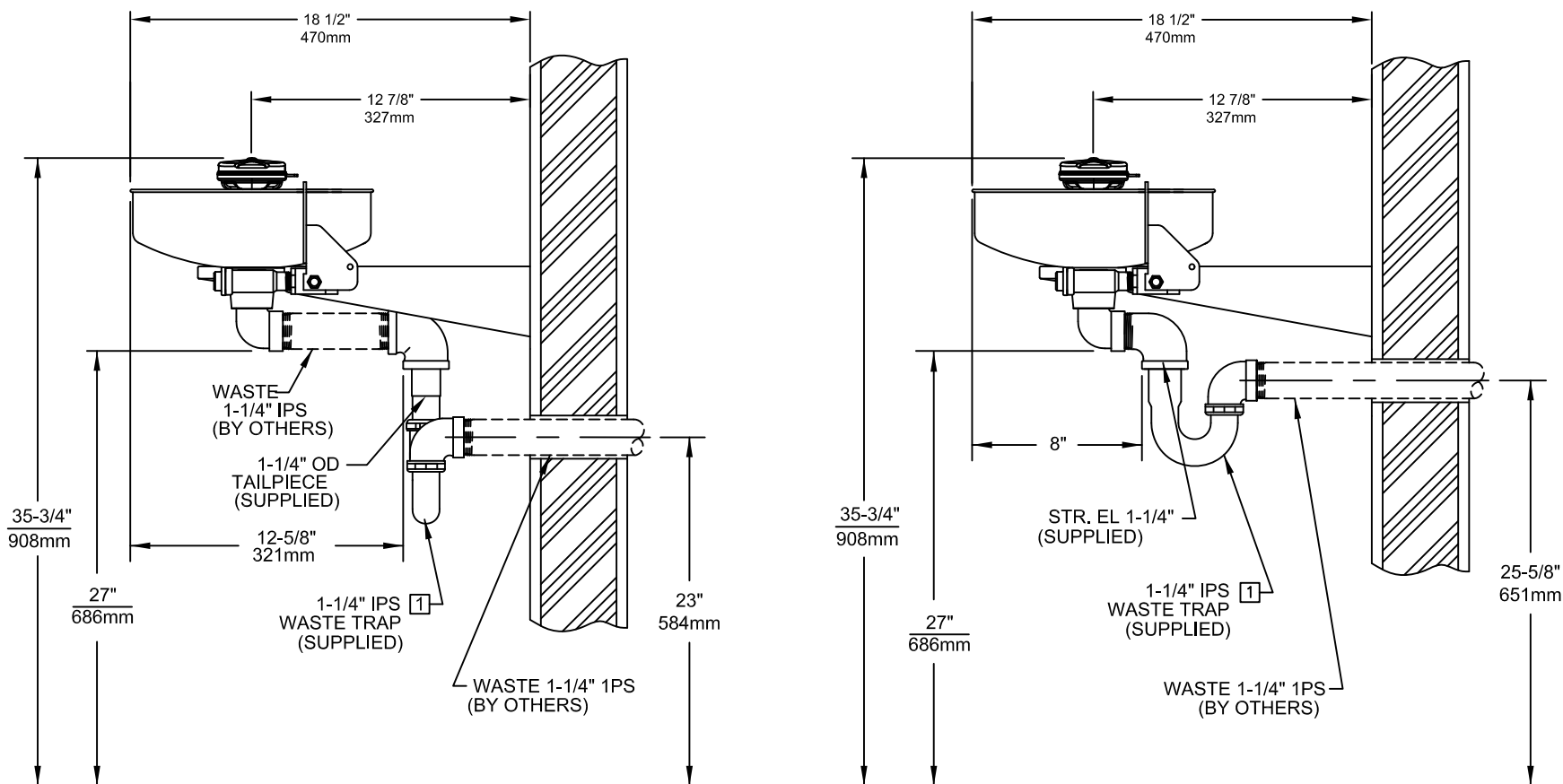

OPTION A

ALTERNATE INSTALLATIONS

OPTION B

NOTE:
 [1] TRAP SHOULD BE WRAPPED TO PROVIDE ADDITIONAL USER PROTECTION.

NOTES:

- TO COMPLY WITH ANSI Z358.1-2009 FOR EMERGENCY EYEWASH OR EYE/FACE WASH AND SHOWER EQUIPMENT:
 - UNIT SHALL BE INSTALLED IN ACCORDANCE WITH MANUFACTURER'S INSTRUCTIONS AND ACCEPTABLE PLUMBING PRACTICES.
 - EYEWASH OR EYE/FACE WASH SHALL BE POSITIONED WITH NOZZLES NOT LESS THEN 83.8 CM (33 IN.) AND NO GREATER THAN 114.3 CM (45 IN.) FROM SURFACE ON WHICH USER STANDS AND 15.3 CM (6 IN.) MINIMUM FROM WALL OR NEAREST OBSTRUCTION.
- DIMENSIONS MAY VARY ±1/2" [12.7mm].

		1455 KLEPPE LANE SPARKS, NEVADA 89431 (775) 359-4712 FAX (775) 359-7424 E-MAIL: HAWS@HAWSCO.COM WEBSITE: WWW.HAWSCO.COM	
		ECN NO. REVISED PER ECN: 4639 DRAWN: FV DATE: 03/98 APPROVED: DATE:	BY: HM CHRD: 7360BTWC INFO FAX DOC #: 27360286 SCALE: 1/8 DRAWING TYPE: INSTALLATION/FAXBACK