

FEATURES & BENEFITS

BYPASS

Best-in-class cold water bypass flow (64% of rated tempered water flow) means continued protection under adverse conditions.

POSITIVE SHUT OFF

Actively suspends hot water flow when cold water supply is lost to protect against scalding.

PRESSURE DROP

Lowest internal pressure drop for this valve class – essential where supply pressure is low.

TEMPERATURE MANAGEMENT

Paraffin-based thermal actuation technology keeps outlet temperature within tight specifications to prevent scalding and hypothermia.

SHUTTLE DESIGN

Superior shuttle design combined with premium material selection eliminates valve binding and reduces maintenance costs.

MIXING CHAMBER

Innovative funnel design generates turbulent flow to ensure consistent temperature blending across entire flow range.

DEPOSITS RESISTANT

Lime and calcium resistant materials used throughout prevent valve sticking and provide a long service life.

FLOW RATES

Flow range of 1 to 78 gpm (295 L) provides service for multiple emergency combination showers or multiple eyewashes, reducing complexity and hardware costs.

MEDICALLY SUPERIOR RESPONSE

AXION's superior design and technology provide a complete safety solution for increased victim comfort.

EXTENDED WARRANTY

3-year extended warranty based on superior engineering and best-in-class material selection means reliable protection you can trust for the long term.



SPECIFICATIONS

Model 9202E - Thermostatic Mixing Valve (patent pending)

	MAXIMUM		MINIMUM	
Flow Rate	78 GPM	295 LPM	1 GPM	4 LPM
Hot Inlet Temperature	180° F	82° C	120° F	49° C
Recommended Hot Inlet Temperature	140° F	60° C		
Cold Inlet Temperature	70° F	21° C	40° F	4° C
Adjustable Outlet Temperature Range	60° F	16° C	90° F	32° C
Operating Pressure	125 PSI	8.6 BAR		
Factory Temperature Set Point	85° F	29° C		
Cold Water Bypass	50 GPM	189 LPM @ 30 PSI		

Inlet Ports: 1-1/4" NPT(f) Outlet Port: 1-1/4" NPT(F)

Maximum Inlet Pressure Differential: +/- 10%

Listings: CSA certified per ASSE 1071 standard and applicable sections of CSA B125.3.

FLOW CAPACITIES

MODEL	INLET	OUTLET	MINIMUM FLOW	INTERNAL COLD WATER BY-PASS AT 30PSI DROP	PRESSURE DROP								
					5	10	15	20	30	45	60	PSI	
9202E	1-1/4"	1-1/4"		50	.345	.689	1.03	1.38	2.07	3.10	4.13	BAR	
					32	45	55	64	78	95	110	GPM	
			4	299	121	170	280	242	295	360	416	L/MIN	



THIS DOCUMENT IS TRUE AND CORRECT AT TIME OF PUBLICATION. CONTAINED PRODUCT IMPROVEMENTS MAKE SPECIFICATIONS AND MEASUREMENTS SUBJECT TO CHANGE WITHOUT NOTICE.

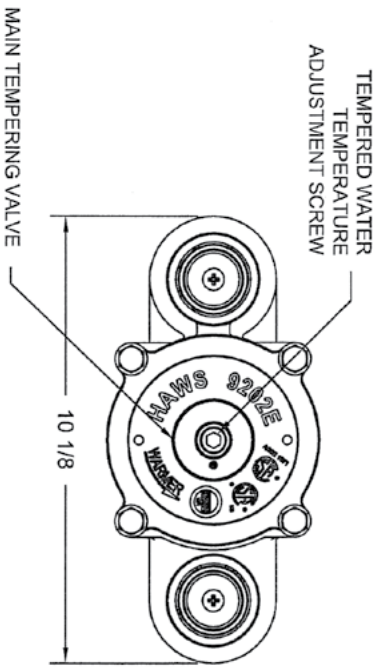
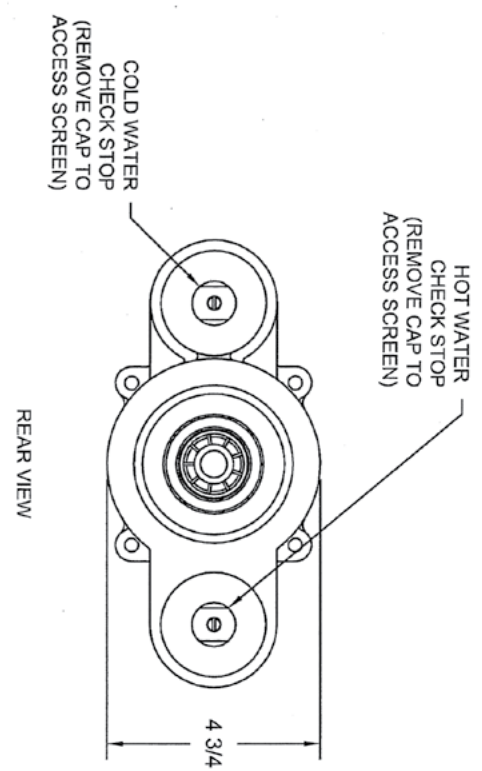
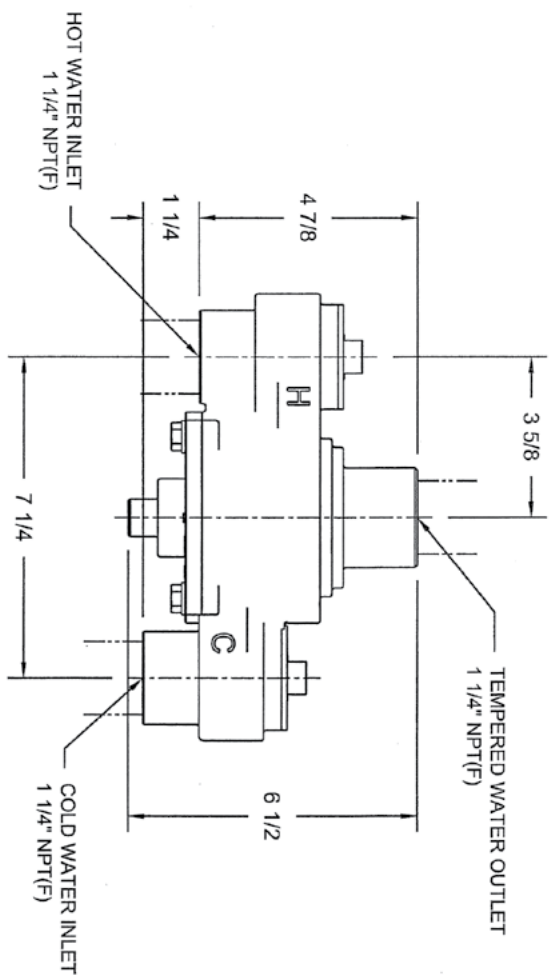

Haws

1455 KLEPPRE LANE
SPARKS, NEVADA 89931
(775) 389-4712 FAX (775) 389-7124
E-MAIL: HAWS@HAWS.CO.COM
WEBSITE: WWW.HAWS.CO.COM

ENGINEER	REVISIONS	DATE	SCALE	DRAWING TYPE	SIZE	SHEET	OF
APPROVED	DATE	SCALE	DRAWING TYPE	SIZE	SHEET	OF	
MODEL(S)	9202E						
PART NUMBER	0002090231.D						
DRAWING NO.	16051A						
REV	4						