



model 9201EFE

AXION® Thermostatic Mixing Valves

FEATURES & BENEFITS

BYPASS

Best-in-class cold water bypass flow (83% of rated tempered water flow) means continued protection under adverse conditions.

POSITIVE SHUT OFF

Actively suspends hot water flow when cold water supply is lost to protect against scalding.

PRESSURE DROP

Lowest internal pressure drop for this valve class – essential where supply pressure is low.

TEMPERATURE MANAGEMENT

Paraffin-based thermal actuation technology keeps outlet temperature within tight specifications to prevent scalding and hypothermia.

SHUTTLE DESIGN

Superior shuttle design combined with premium material selection eliminates valve binding and reduces maintenance costs.

MIXING CHAMBER

Innovative funnel design generates turbulent flow to ensure consistent temperature blending across entire flow range.

DEPOSITS RESISTANT

Lime and calcium resistant materials used throughout prevent valve sticking and provide a long service life.

FLOW RATES

Flow range of 1 to 12 GPM (45.4 L) provides service for one or two safety eyewashes, reducing complexity and hardware costs.

MEDICALLY SUPERIOR RESPONSE

AXION's superior design and technology provide a complete safety solution for increased victim comfort.

EXTENDED WARRANTY

3-year extended warranty based on superior engineering and best-in-class material selection means reliable protection you can trust for the long term.

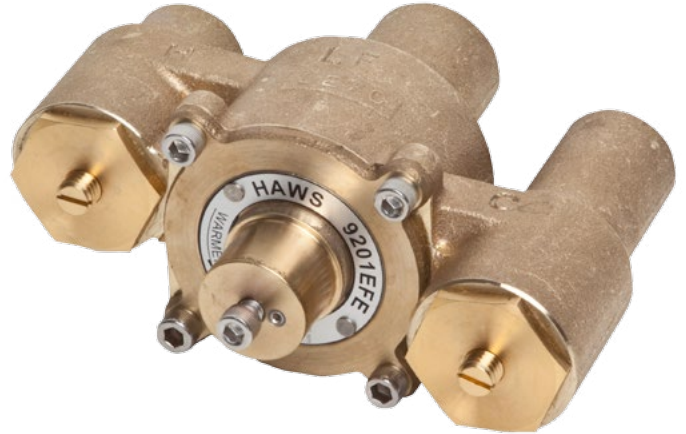

SPECIFICATIONS

Model 9201EFE - Thermostatic Mixing Valve (patent pending)

	MAXIMUM		MINIMUM	
Flow Rate	12 GPM	45.4 LPM	1 GPM	4 LPM
Hot Inlet Temperature	180° F	82° C	120° F	49° C
Recommended Hot Inlet Temperature	140° F	60° C		
Cold Inlet Temperature	70° F	21° C	40° F	4° C
Adjustable Outlet Temperature Range	90° F	32° C	60° F	16° C
Operating Pressure	125 PSI	8.6 BAR		
Factory Temperature Set Point	85° F	29° C		
Cold Water Bypass	10 GPM	37.8 LPM @ 30 PSI		

Inlet Ports: 1/2" NPT(f) Outlet Port: 3/4" NPT(F)

Maximum Inlet Pressure Differential: +/- 10%

Listings: CSA certified per ASSE 1071 standard and applicable sections of CSA B125.3.

FLOW CAPACITIES

MODEL	INLET	OUTLET	MINIMUM FLOW	INTERNAL COLD WATER BY-PASS AT 30PSI DROP	PRESSURE DROP							
					5	10	15	20	30	45	60	PSI
9201EFE	1/2"	3/4"			.345	.689	1.03	1.38	2.07	3.10	4.13	BAR
			1	10	5	7	8.5	10	12	15	17	GPM
			4	38	18.5	26	32	37	45	55.6	64	L/MIN



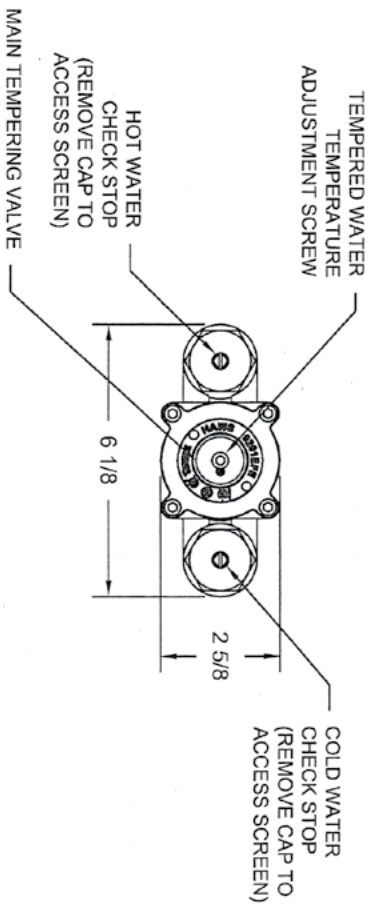
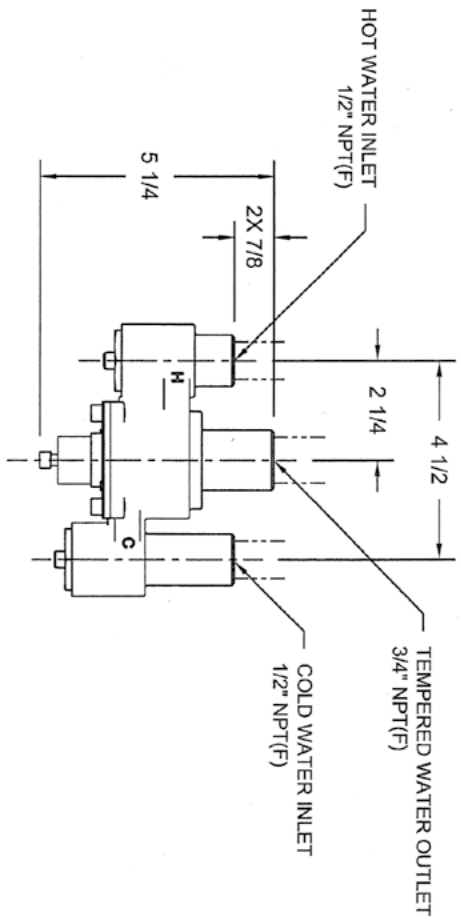

1485 KLEPPE LANE
 SPARKS, NEVADA, 89431
 (775) 359-4712 FAX (759) 359-4424
 E-MAIL: HAWS@HAWSCO.COM
 WEBSITE: WWW.HAWSCO.COM

ECON NO. REVISED PER BY:	MODEL(S)	PART NUMBER
4308	9201EFFE	0002080234 D
DRWING NO. 10/10	SCALE: 1/4"	DRWING NO. 16053A
APPROVED: [Signature]	DATE: 10/10	REV: 4
DRAWING TYPE: INSTALLATION		SIZE: A
SHEET: 1		OF: 1