



□ G1825BC Eyewash, Pedestal Mounted, Stainless Steel Bowl and Cover

Application: Free standing, pedestal mounted eyewash. Unit has stainless steel cover to protect bowl from dust, dirt and other contaminants. Two GS-Plus™ spray-type spray heads deliver a flood of water for rinsing eyes.

Spray Head Assembly: Two GS-Plus™ spray heads. Each head has an internal flow control and filter to remove impurities from the water flow.

Valve: 1/2" IPS chrome plated brass stay-open ball valve. Valve is US-made with chrome plated brass ball and Teflon® seals.

Bowl: 11-1/2" stainless steel with bowl cover. Cover is raised automatically when flag handle is activated. Cover closes when handle is returned to closed position.

Pipe and Fittings: Schedule 40 galvanized steel. Furnished with orange polyethylene covers for vertical piping for high visibility and corrosion resistance.

Supply: 1/2" NPT female inlet.

Waste: 1-1/4" NPT female outlet.

Sign: ANSI-compliant identification sign.

Quality Assurance: Valve, bowl and spray head assembly is factory assembled and water tested prior to shipment.

Available Options

- **HFC** Hand and foot control. Eyewash is activated by flag handle or foot treadle.
- **HS** Auxiliary hand-held drench hose for rinsing eyes, face or body.
- **TMV** G3600 thermostatic mixing valve precisely blends hot and cold water to deliver warm (tepid) water as required by ANSI Z358.1-2009. Refer to "Tempering Units" section for complete technical and product selection information.





□ G1825BC Eyewash, Pedestal Mounted, Stainless Steel Bowl and Cover

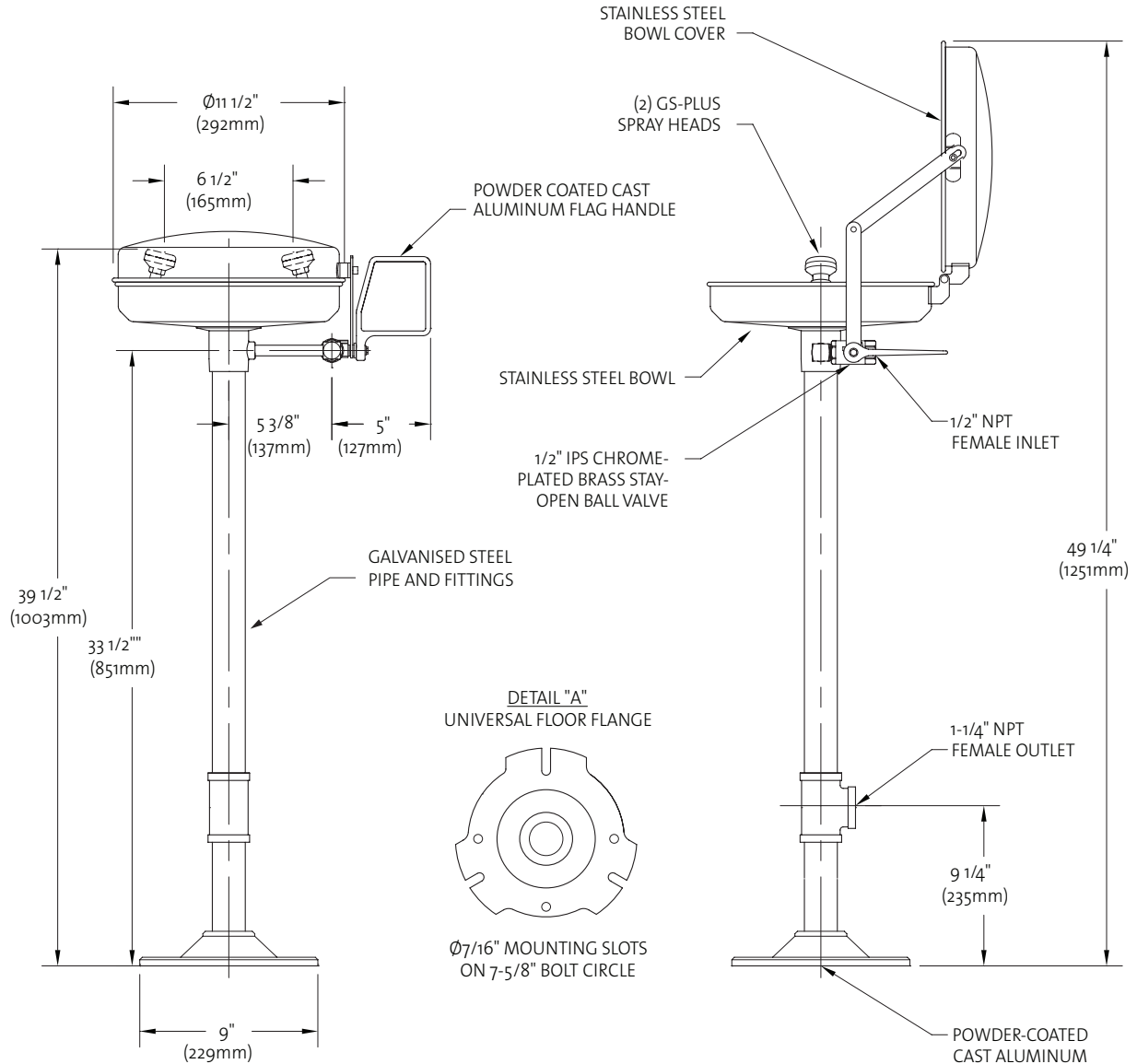

NOTE:
EACH GS-PLUS SPRAY HEAD HAS AN INTERNAL FLOW CONTROL AND FILTER TO REMOVE IMPURITIES FROM THE WATER FLOW.

THIS SPACE FOR ARCHITECT/ENGINEER APPROVAL

Due to continuing product improvement, the information contained in this document is subject to change without notice. All dimensions are $\pm 1/4"$ (6mm). rev. 0114

Sign Included

