

CART-550-SS & CART-1100-SS

Instruction Manual



After delivery, immediately remove the packaging from the product in a manner that preserves the packaging and maintains the orientation of the product in the packaging; then inspect the product closely to determine whether it sustained damage during transport. **If damage is discovered during the inspection, immediately record a complete description of the damage on the bill of lading.** If the product is undamaged, discard the packaging.

NOTES:

- 1) Compliance with laws, regulations, codes, and non-voluntary standards enforced in the location where the product is *used* is exclusively the responsibility of the owner/end-user.
- 2) The manufacturer is **not liable** for any injury or property damage that occurs as a consequence of failing to apply a) the instructions in this manual; or b) information provided on labels affixed to the product. Neither is the we responsible for *any* consequential damages sustained as a result of failing to exercise sound judgment while assembling, installing, using or maintaining this product.

<u>Table of Contents</u>	<u>Page</u>
Hazard Identification: explanation of signal words.....	2
Safety Guidelines.....	2
Product Introduction.....	3
Bills of materials for CART-550-SS and 1100-SS.....	5, 7
Assembly Instructions.....	8
Use Instructions.....	9-11
Loading.....	9
Lift Table Operation.....	10
Hydraulic System Operation.....	10-11
Inspections & Maintenance.....	12
Troubleshooting.....	13
<u>Table of Figures</u>	
FIG. 1: CART-550-SS Exploded Parts Diagram.....	4
FIG. 2: CART-1100-SS Exploded Parts Diagram.....	6
FIG. 3: Hydraulics Diagram.....	8
FIG. 4: Spline and Pin Connection.....	8
FIG. 5: Handle Insertion.....	8
FIG. 6: Pedal Attachment.....	8
FIG. 7A & 7B: Proper Load Positioning (Top View & Side View).....	9
FIG. 8: Caster Brake Lever.....	10
FIG. 9: Hydraulic Control Pedal Positions.....	11
FIG. 10: Maintenance Prop Installation.....	12
FIG. 11: Label Placement.....	14

HAZARD IDENTIFICATION: explanation of signal words

This manual uses SIGNAL WORDS to indicate the likelihood of personal injuries, as well as the probable seriousness of those injuries, if the product is misused in the ways described. Other signal words call attention to uses of the product likely cause property damage.

The signal words used appear below along with the meaning of each word:



Identifies a hazardous situation which, if not avoided, **WILL** result in DEATH or SERIOUS INJURY. Use of this signal word is limited to the most extreme situations.



Identifies a hazardous situation which, if not avoided, **COULD** result in DEATH or SERIOUS INJURY.



Indicates a hazardous situation which, if not avoided, **COULD** result in MINOR or MODERATE injury.



Identifies practices likely to result in product/property damage, such as operation that might damage the product.

Each person who assembles, installs, uses, or maintains this product should read the entire manual and fully understand the directions in advance. If after reading the manual you do not understand an instruction, ask your supervisor or employer for clarification, because failure to adhere to the directions in this manual might result in serious personal injury.

SAFETY GUIDELINES

We strive to identify foreseeable hazards associated with the use of its products. However, material handling is inherently dangerous and no manual can address every conceivable risk. The end-user ultimately is responsible for exercising sound judgment at all times.



Failure to read and understand the entire manual before assembling, installing, using and servicing the product is a misuse of the product. If this product is used improperly or carelessly, the user and/or bystanders might sustain serious personal injuries. To reduce the likelihood of injury:

- DO NOT modify the product in any way UNLESS you first obtain written approval. Unauthorized modifications automatically void the Limited Warranty and might make the product unsafe to use.
- DO NOT attempt to service a loaded cart. Unload the cart and install maintenance props according to the directions on p. 13 BEFORE working on the cart. DO NOT work under the lift without using the maintenance devices.
- DO NOT attempt to lift or transport loads that exceed the capacity of the cart.
- DO NOT stand, sit or ride on the cart.
- DO NOT put hands or feet under the deck at any time UNLESS the maintenance props are in place.
- Stand clear of the cart while the lift table is moving.
- Keep clear of pinch points! As the deck rises and lowers, pinch points occur between the leg weldments (see Fig. 11, p. 15). NEVER reach into or put any part of your body inside the scissors mechanism.
- DO NOT use the scissors lift cart UNLESS all safety labels are in place and readable.
- DO NOT use the cart if you hear unusual sounds while raising or lowering the deck.
- Always watch the load carefully while raising or lowering the deck.
- ONLY use the cart on compacted, improved surfaces.
- DO NOT leave a loaded cart unattended. ALWAYS unload the cart, and return it to the designated storage location BEFORE you leave the cart unattended.
- DO NOT store the cart outdoors or in corrosive environments.



- Proper use, maintenance, and storage are essential for this product to function properly.
- Always use this product in accordance with the instructions in this manual and consistent with any training relevant to machines, devices, etc. used in conjunction with this product.
 - Periodically lubricate moving parts.
 - Keep the product clean & dry.
 - Only use approved replacement parts. To order replacement or spare parts for this equipment, contact the factory.

PRODUCT INTRODUCTION



Thank you for purchasing a hydraulic elevating cart (“cart,” “scissor lift cart,” “product,” “unit,” or simply referenced by model number). Our carts are durable, high-quality products that combine safety features and low-maintenance stainless steel mechanisms. Despite the product’s relatively simple mechanics, all personnel must familiarize themselves with the safe operation instructions provided in this manual.

Specifications for the two stainless steel cart models appear in the table below:

	<u>Net Wt. (lbs.)</u>	<u>Platform Size (W x L) in inches</u>	<u>Vertical Range of Motion (in.)</u>	<u>Capacity (lbs.)</u>
CART-550-SS	160	19 - $\frac{1}{2}$ " x 31 - $\frac{1}{2}$ "	9 - $\frac{3}{4}$ " to 33 - $\frac{1}{2}$ "	550
CART-1100-SS	240	23 - $\frac{1}{2}$ " x 35 - $\frac{1}{2}$ "	13" to 38 - $\frac{1}{2}$ "	1,100

This manual was made to acquaint owners and users of our stainless steel carts with safe use and maintenance procedures. **Employers are responsible for instructing employees to use the product properly. Employees and any other persons, who might foreseeably use, repair, or perform maintenance on the cart must read and understand every instruction before using the device. Cart operators should have access to the manual at all times and should review the directions before each use. Contact us for answers to any question you have after reading the entire manual.**

Although we strive to identify foreseeable hazardous situations, this manual cannot address every conceivable danger. The end-user is ultimately responsible for exercising sound judgment at all times.

FIG. 1: CART-550-SS Exploded Parts Diagram

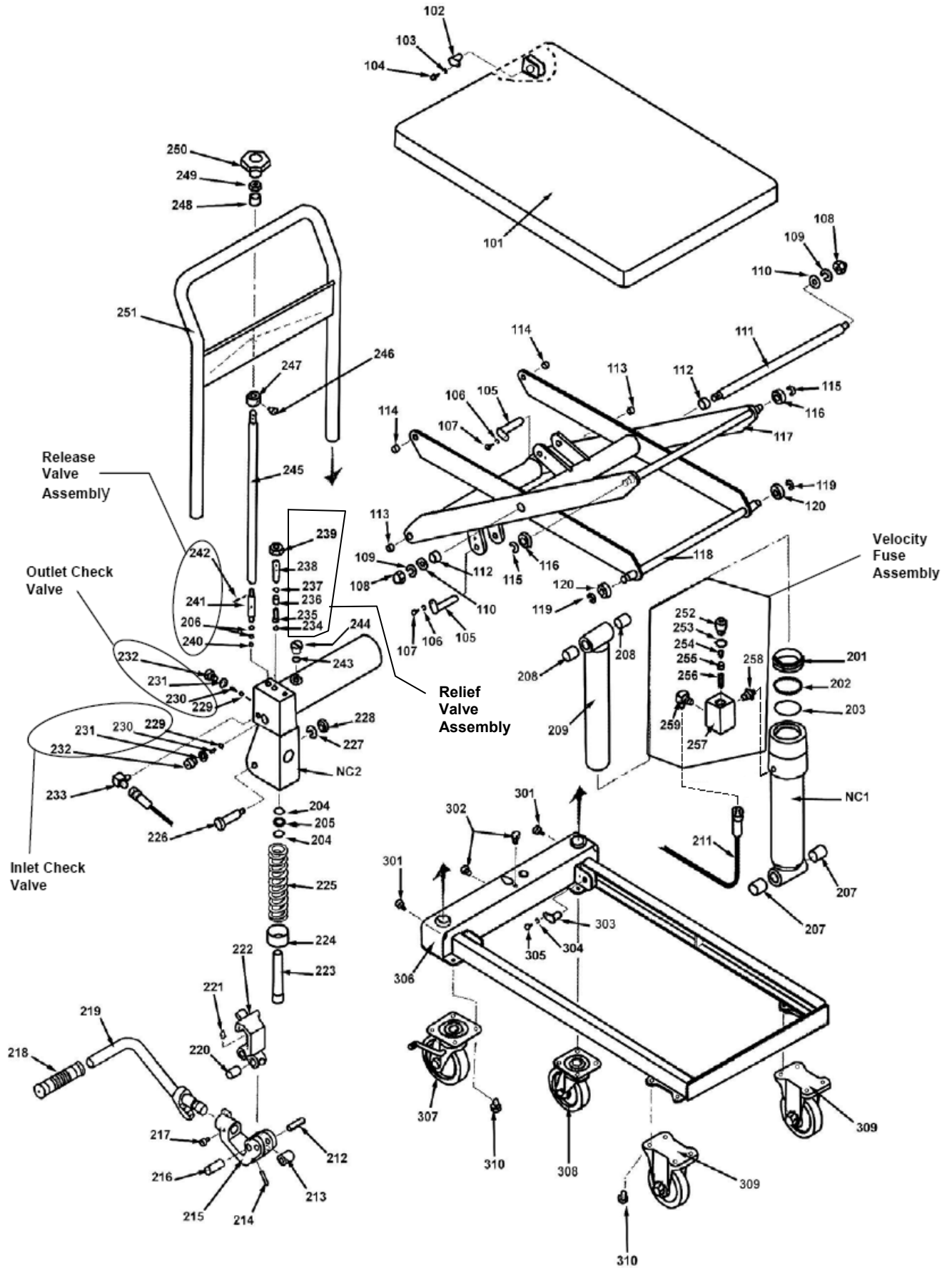

CART-550-SS bill of materials

Item No.	Part No.	Description	Item No.	Part No.	Description
101	C-500-SS-101	Table Deck	227	C-500-SS-227	Washer
102	C-500-SS-102	Arm Pin	228	C-500-SS-228	Nut
103	C-500-SS-103	Washer	Inlet & Outlet Check Valves		
104	C-500-SS-104	Bolt	229	C-500-SS-229	Steel Ball
105	C-500-SS-105	Cylinder Pin	230	C-500-SS-230	Spring
106	C-500-SS-106	Washer	231	C-500-SS-231	Washer
107	C-500-SS-107	Bolt	232	C-500-SS-232	Threaded Cavity Plug
108	C-500-SS-108	Cap Nut	233	C-500-SS-233	Elbow
109	C-500-SS-109	Washer	Relief Valve Assembly		
110	C-500-SS-110	Washer	234	C-500-SS-234	Steel Ball
111	C-500-SS-111	Scissor Pivot Shaft	235	C-500-SS-235	Relief Spring Guide
112	C-500-SS-112	Bushing	236	C-500-SS-236	Relief Spring
113	C-500-SS-113	Bushing	237	C-500-SS-237	O-Ring
114	C-500-SS-114	Bushing	238	C-500-SS-238	Adjustment Screw
115	C-500-SS-115	Snap Ring	239	C-500-SS-239	Nut
116	C-500-SS-116	Roller (bearing)	Release Valve Mechanism		
117	C-500-SS-117	Outer Scissor Arm	206	C-500-SS-206	O-Ring
118	C-500-SS-118	Roller Bearing Shaft	240	C-500-SS-240	¼ inch Steel Ball
119	C-500-SS-119	Snap Ring	241	C-500-SS-241	Release Valve Stem
120	C-500-SS-120	Roller (bearing)	242	C-500-SS-242	Roll Pin
201	C-500-SS-201	Dust Seal	243	C-500-SS-243	Oil Fill Plug O-Ring
202	C-500-SS-202	Backup Ring	244	C-500-SS-244	Oil Reservoir Fill Plug
203	C-500-SS-203	O-Ring	245	C-500-SS-245	Release Valve Shaft
204	C-500-SS-204	O-Ring	246	C-500-SS-246	Bushing Retaining Bolt
205	C-500-SS-205	Backup Ring	247	C-500-SS-247	Shaft Retaining Bushing
206	C-500-SS-206	O-Ring	248	C-500-SS-248	Guide
207	C-500-SS-207	Bushing	249	C-500-SS-249	Nut
208	C-500-SS-208	Bushing	250	C-500-SS-250	Release Knob
209	C-500-SS-209	Piston Ring	251	C-500-SS-251	Handle
211	C-500-SS-211	Hose	Velocity Fuse Assembly		
212	C-500-SS-212	Spring Pin	252	C-500-SS-252	Adjustment Screw + Nut
213	C-500-SS-213	Plunger Roller	253	C-500-SS-253	Washer
214	C-500-SS-214	Spring Pin	254	C-500-SS-254	Spring
215	C-500-SS-215	Pedal Boss	255	C-500-SS-255	Safety Velocity Spool
216	C-500-SS-216	Pedal Boss Pin	256	C-500-SS-256	Spring
217	C-500-SS-217	Socket Bolt	257	C-500-SS-257	Valve Base
218	C-500-SS-218	Pedal Cover	258	C-500-SS-258	Nipple
219	C-500-SS-219	Pedal shaft	259	C-500-SS-259	Elbow
220	C-500-SS-220	Bushing			
221	C-500-SS-221	Grease Nipple	301	C-500-SS-301	Socket Bolt
222	C-500-SS-222	Pedal Link	302	C-500-SS-302	Bolt
223	C-500-SS-223	Plunger Piston	303	C-500-SS-303	Arm Pin
224	C-500-SS-224	Spring Cap	304	C-500-SS-304	Washer
225	C-500-SS-225	Return Spring	305	C-500-SS-305	Bolt
226	C-500-SS-226	Pedal Pin	306	C-500-SS-306	Reservoir Housing
			307	C-500-SS-307	Locking Swivel Caster
			308	C-500-SS-308	Swivel Caster
Replacement Parts Kits:			309	C-500-SS-309	Rigid Caster
901	C-500-SS-901	Seal Kit	310	C-500-SS-310	Bolt
941	C-500-SS-941	Cylinder Assembly			
942	C-500-SS-942	Pump Assembly			

FIG. 2: CART-1100-SS Exploded Parts Diagram

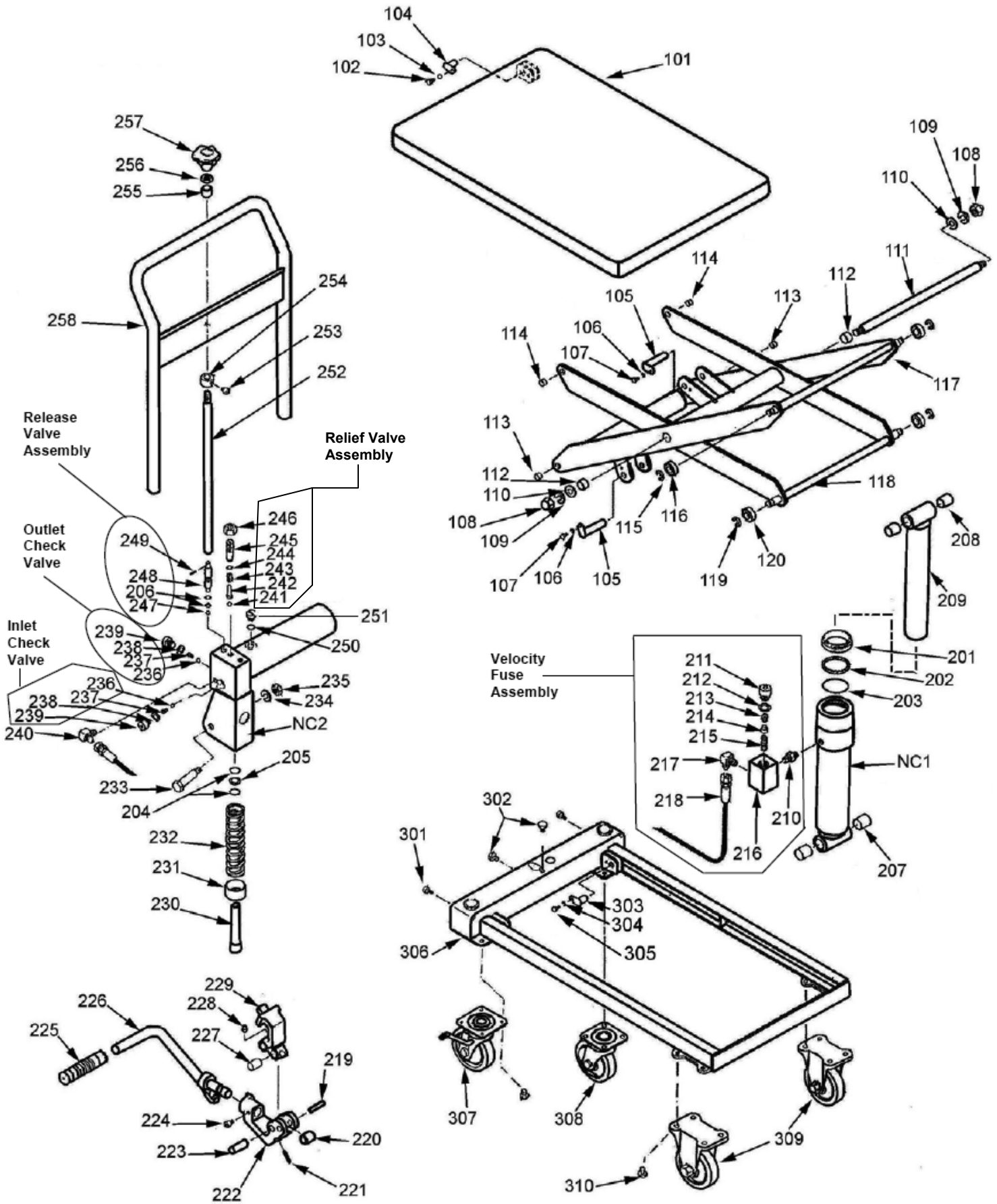

CART-1100-SS bill of materials

Item No.	Part No.	Description	Item No.	Part No.	Description
101	C-1100-SS-101	Deck (of table)	227	C-1100-SS-227	Bushing
102	C-1100-SS-102	Bolt	228	C-1100-SS-228	Grease Nipple
103	C-1100-SS-103	Stainless Washer	229	C-1100-SS-229	Pedal Link
104	C-1100-SS-104	Arm Pin	230	C-1100-SS-230	Plunger Piston
105	C-1100-SS-105	Cylinder Pin	231	C-1100-SS-231	Spring Cap
106	C-1100-SS-106	Stainless Washer	232	C-1100-SS-232	Return Spring
107	C-1100-SS-107	Bolt	233	C-1100-SS-233	Pedal Pin
108	C-1100-SS-108	Cap Nut	234	C-1100-SS-234	Stainless Washer
109	C-1100-SS-109	Stainless Washer	235	C-1100-SS-235	Nut
110	C-1100-SS-110	Washer	Inlet & Outlet Check Valve Assembly		
111	C-1100-SS-111	Scissor Pivot Shaft	236	C-1100-SS-236	Steel Bearing
112	C-1100-SS-112	Bushing	237	C-1100-SS-237	Spring
113	C-1100-SS-113	Bushing	238	C-1100-SS-238	Washer
114	C-1100-SS-114	Bushing	239	C-1100-SS-239	Valve Plug
115	C-1100-SS-115	Snap Ring	240	C-1100-SS-240	Elbow
116	C-1100-SS-116	Roller (bearing)	Relief Valve Assembly		
117	C-1100-SS-117	Outer Scissor Arm	241	C-1100-SS-241	Steel Bearing
118	C-1100-SS-118	Roller Bearing Shaft	242	C-1100-SS-242	Spring Guide
119	C-1100-SS-119	Snap ring	243	C-1100-SS-243	Spring
120	C-1100-SS-120	Roller (bearing)	244	C-1100-SS-244	O-Ring
			245	C-1100-SS-245	Adjustment Screw
201	C-1100-SS-201	Dust Seal	246	C-1100-SS-246	Nut
202	C-1100-SS-202	Backup Ring	Release Valve Assembly		
203	C-1100-SS-203	O-Ring	206	C-1100-SS-206	O-Ring
204	C-1100-SS-204	O-Ring	247	C-1100-SS-247	Steel Bearing
205	C-1100-SS-205	Backup Ring	248	C-1100-SS-248	Release Valve Stem
206	C-1100-SS-206	O-Ring			
207	C-1100-SS-207	Bushing	249	C-1100-SS-249	Roll Pin
208	C-1100-SS-208	Bushing			
209	C-1100-SS-209	Piston Rod	250	C-1100-SS-250	Fill Plug O-Ring
Velocity Fuse Assembly			251	C-1100-SS-251	Oil Fill Plug
210	C-1100-SS-210	Nipple	252	C-1100-SS-252	Pressure Release Shaft
211	C-1100-SS-211	Valve Plug	253	C-1100-SS-253	Socket Bolt
212	C-1100-SS-212	Washer	254	C-1100-SS-254	Shaft Retaining Bushing
213	C-1100-SS-213	Spring	255	C-1100-SS-255	Guide
214	C-1100-SS-214	Spool	256	C-1100-SS-256	Nut
215	C-1100-SS-215	Spring	257	C-1100-SS-257	Release Knob
216	C-1100-SS-216	Valve Base	258	C-1100-SS-258	Handle
217	C-1100-SS-217	Nipple			
218	C-1100-SS-218	Hose	301	C-1100-SS-301	Socket Bolt
			302	C-1100-SS-302	Bolt
219	C-1100-SS-219	Spring Pin	303	C-1100-SS-303	Arm Pin
220	C-1100-SS-220	Plunger Roller	304	C-1100-SS-304	Stainless Washer
221	C-1100-SS-221	Spring Pin	305	C-1100-SS-305	Bolt
222	C-1100-SS-222	Pedal Boss	306	C-1100-SS-306	Frame
223	C-1100-SS-223	Pedal Boss Pin	307	C-1100-SS-307	Locking Caster
224	C-1100-SS-224	Socket Bolt	308	C-1100-SS-308	Swivel Caster
225	C-1100-SS-225	Pedal Cover	309	C-1100-SS-309	Rigid Caster
226	C-1100-SS-226	Pedal	310	C-1100-SS-310	Bolt
Replacement Parts Kits:					
	901	C-1100-SS-901	Seal Kit		
	941	C-1100-SS-941	Cylinder Assembly		
	942	C-1100-SS-942	Pump Assembly		

FIG. 3: Hydraulics Diagram

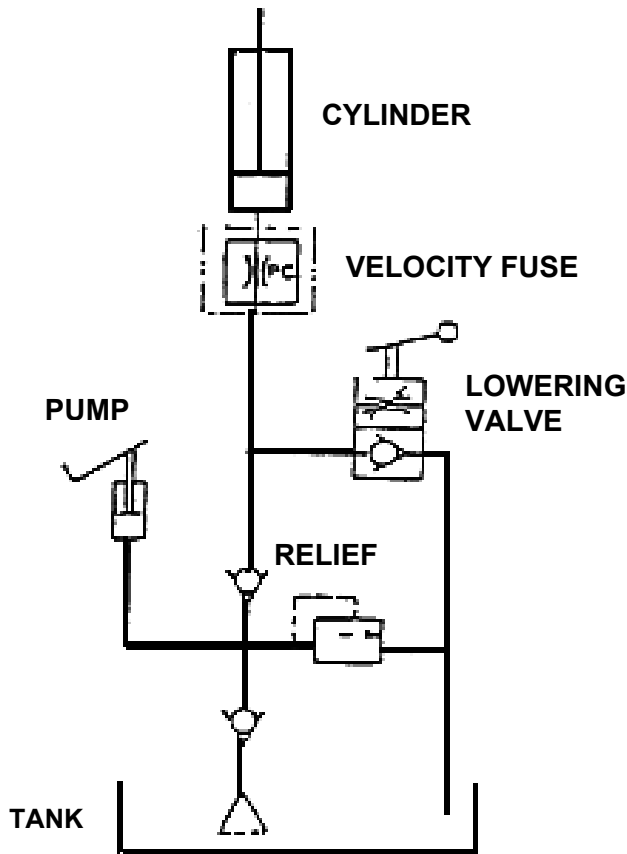

⚠ WARNING To reduce the possibility of injury, BEFORE working on the hydraulic system:

1. Fully lower and secure the deck;
2. Release system pressure and disconnect all power sources;
3. DO NOT work on the hydraulic components UNLESS you are trained and authorized to do so.

NOTICE DO NOT use brake fluid or jack oils in the hydraulic system. Replace the oil with anti-wear hydraulic oil having a viscosity of 150 SUS at 100°F (ISO 32 @ 40°C), or non-synthetic transmission fluid.

Assembly Instructions:

As shipped, the cart requires minimal assembly. In addition to the deck and chassis assembly, you should receive the following hardware:

- 3 Socket-head cap screws
- 1 L-shaped hex wrench (to tighten bolts)
- 1 Hydraulic pump foot pedal
- 1 Handle assembly

1. Close the release valve by turning it clockwise until it is snug.
2. Insert the open end of the handle into the openings in the frame (FIG. 5). Fix the handle into position using the socket-head cap-screws and supplied hex-wrench.
3. Insert the end of the pressure relief shaft (item #245 in FIG. 1; item #252 in FIG. 2) over the release-valve stem (item #241 in FIG. 1; item #249 in FIG. 2) The slot in the shaft and the roll pin on the valve stem must align. Proper fit is shown in FIG. 5.
4. Attach the foot pedal to the receptacle and secure the pedal with a socket-head cap-screw. (see FIG. 6) When properly installed and secured, the pedal will be able to rotate 90° to the right and left of center allowing the use of the 2-speed pump feature.

FIG. 4: Spline & Roll Pin Connection



FIG. 5: Handle Insertion

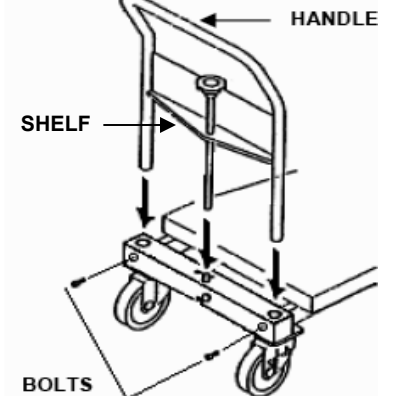
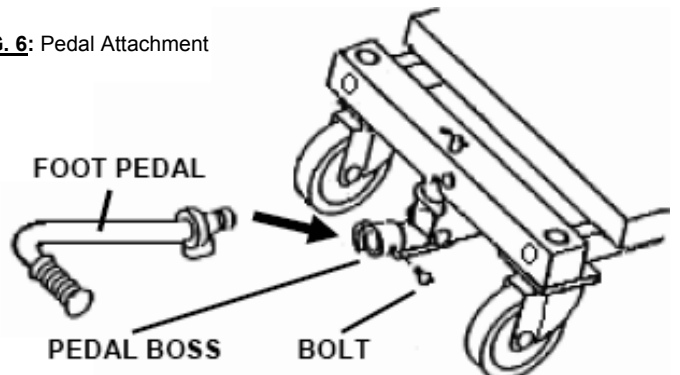

FIG. 6: Pedal Attachment



Use Instructions:

The cart is suitable for use in most industrial and commercial settings. Only *authorized persons* should use the scissors lift cart. "Authorized person" means someone the end-user approves or assigns to use the cart because he/she is either:

1. **Qualified:** Someone with demonstrated ability to deal with problems relating to the scissors lift cart by virtue of having a recognized degree, certificate, or professional standing, and who additionally has knowledge of, training related to, and experience with scissor lifts carts; AND/OR
2. **Trained:** Someone trained by a qualified person and who has demonstrated the ability to perform particular function(s) on or around a scissor lift.

Only use the cart to transport and lift stable, evenly distributed, non-hazardous loads and containers with rigid sides.

LOADING:

Any load put on the cart should be approximately the same size as the deck or smaller.

Center and evenly distribute a load on the deck. Position the center of the load between the scissor legs and on the deck midline as shown in figures 7A & 7B below.

⚠ WARNING If the cart is improperly loaded, the operator and/or bystanders might be seriously injured:

1. The rated load (in pounds) of the cart appears on the product data label, which is affixed to the left corner of the operator end of the deck. The rated load indicates the **net capacity** of the cart, i.e. the weight of all accessory equipment added to the cart must be added to the weight of the load. The total weight must be less than or equal to the rated capacity of the cart:
$$\text{Weight of load} + \text{weight of accessories} = (\text{or less than}) \text{ Cart Capacity}$$
2. Always properly stabilize the cart and the load:
 - a. If the load might roll or slide off of the deck, immobilize it and secure it to the deck before moving the cart. For example, round material like pipe might roll off of the deck. Immobilize the pipe with chocks and use one or more straps to secure the pipe and chocks in place on the deck.
 - b. **DO NOT** front load or rear load the cart. This means that you should not center a load on the portions of the deck highlighted in FIG.'s 7A & 7B, "DO NOT center load here". For applications involving side or end edge loading, contact the factory.

FIG. 7A: Proper Load Positioning (Side View)

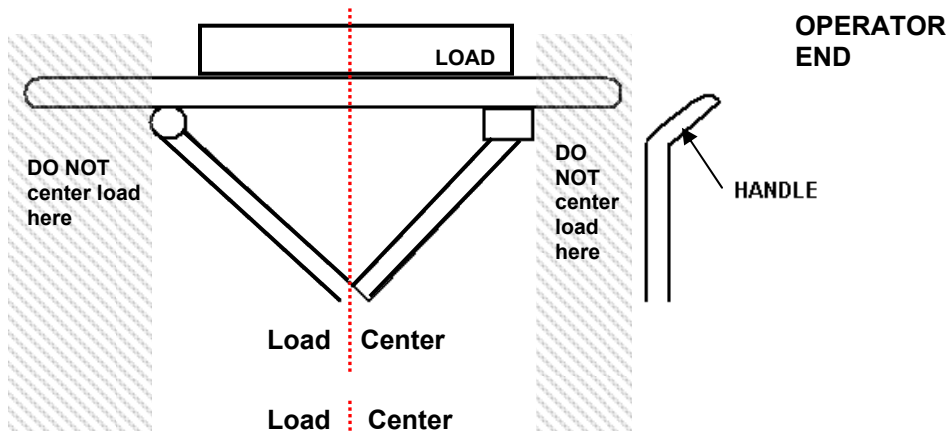
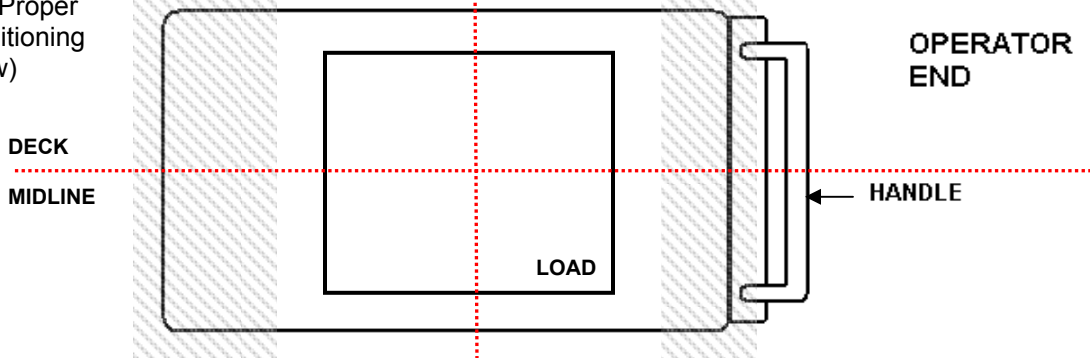

FIG. 7B: Proper Load Positioning (Top View)



Lift Table Operation :

WARNING

Take reasonable precautions to avoid the **obvious potential hazards** of using a cart:

1. Instruct other persons in the area to stand at a safe distance while raising or lowering the deck. Be certain no part of any person, clothing, or object is under any part of the cart before lowering the deck.
2. DO NOT use the cart if:
 - (a) You notice any damage or hear unusual noise(s) while raising or lowering the deck;
 - (b) It requires maintenance or repairs;
- OR -
 - (c) The cart malfunctions in any way. Tag the cart "Out of Service" and immediately notify your supervisor or maintenance personnel.
3. DO NOT park on or push the cart across inclined surfaces. Drive the cart straight up or straight down inclined surfaces. The load may shift while traversing an incline, so secure the load to the deck, for example with straps, BEFORE attempting to drive the cart over the incline. ALWAYS push the cart up/down an incline.
4. DO NOT transport a load with the deck in the fully raised position. Always transport loads with the deck fully lowered. Transport the load to the unloading point, and then raise the deck to the necessary height. After unloading the cart, fully lower the deck.
5. Do not over-tighten the release valve!



To raise the deck:

1. Make sure that the release valve is closed by turning the release knob clockwise until it is tight.
2. Step on the brake lever to apply the caster brake. (Fig. 9)
3. Put the load on the deck using the "LOADING" instructions on p. 10.
4. Turn the pedal to Position 2 (see below Fig. 9).
5. Pump the pedal with your foot and continue to do so until the deck reaches the desired elevation. The table has an upper travel limit; the deck will not rise above ~33 inches.

[NOTE: If the table is unloaded, you may use the high speed option for raising the deck. Turn the pedal to Position 1; then pump the pedal until the desired deck position is achieved.]

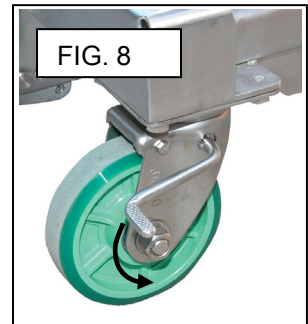

To lower the deck: slowly turn the release knob counterclockwise to open the release valve. The deck will lower more rapidly the farther you turn the knob. Do not let the deck descend rapidly, but rather allow the deck to slowly lower to the fully lowered position. Once the deck is fully lowered, close the release valve by turning the release knob clockwise. [NOTE: The hydraulic system cannot pressurize, and the deck will not rise in response to pumping the pedal, if the release valve is open. Always make sure to turn the knob clockwise after the deck is fully lowered to close the valve.]

The cart is manually propelled. After loading the cart and properly securing the load to the deck, push the cart to the desired location. Do not exceed a rate of two feet per second when transporting a load with the cart.

Hydraulic system operation:

Hydraulic components are all rated for 2,500 psi working pressure.

Key components and specifications of the hydraulic system include:

- Check valve: prevents backflow of fluid through the pump. It allows the deck to hold a given elevation. However, leaks in the system will cause the deck to lower over time.
- Pressure relief valve: opens a path for fluid to follow to the reservoir if the fluid pressure exceeds a threshold (maximum).
- Safety velocity fuse: installed in the housing connected to the cylinder. It closes automatically if a catastrophic hose failure occurs, and closing the fuse prevents the lift table from collapsing. The velocity fuse is designed to slowly lower the deck by allowing gradual depressurization of the hydraulic system.
- 2 Pump Speeds: To raise the deck, pump the pedal with your foot. 2 speeds are available for raising the deck. When the pedal is in position 1, the deck will rise at a faster rate; in position 2, the deck rises more slowly. To switch between speeds, rotate the handle.
- Release/Lowering Valve: turn the release knob to lower the deck.

FIG. 9: Hydraulic Control Pedal Positions

POSITION 1: HIGH SPEED FOR RAISING DECK ONLY (UNLOADED)

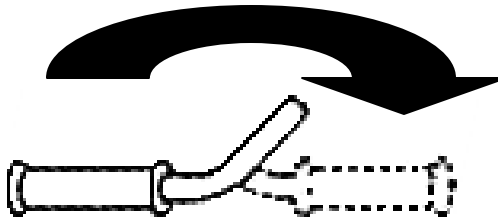

POSITION 2: LOW SPEED FOR LIFTING

To lower the deck, open the release valve by turning the release knob counterclockwise. The release knob is item #250 in FIG. 1, and item #257 in FIG. 2. As you turn the knob, the lowering valve opens, which creates a bypass around the check valve and the oil in the cylinder returns to the reservoir through the return hose.

If the deck continues to slowly lose elevation even though the release valve is closed, remove the lowering (release) valve for inspection and cleaning.

Release Valve Removal & Cleaning Procedure:

1. Unload the cart.
2. Raise the deck and then install maintenance props in the roller channel (both sides) as indicated in FIG. 10 on page 13.
3. Unscrew and remove the valve (Item 241 in FIG. 1; Item 248 in FIG. 2) from the manifold
4. Use a small diameter magnet to remove the steel ball at the bottom of the valve cavity (Item 240 in FIG. 1; Item 247 in FIG. 2).
5. Inspect the valve stem and ball for contaminants.
6. Inspect the o-rings and back-up washers located on the valve stem for cuts, tears or other damage
7. Use mineral spirits (or kerosene) to clean contaminants from the valve stem, o-rings, back-up washers, steel ball and valve cavity.
8. Inspect the ball seat at the bottom of the valve cavity. The ball seat should be a crisp, donut-shaped shiny area with a hole in the center. If it is not, it may be necessary to "stake" the ball into place. This is done by inserting the ball into the cavity and striking it using a 1/4" grade-2 bolt and a small hammer. This will create a new seat on which the ball will seal and prevent the oil from leaking.

There are 2 reasons why the deck might continue to slowly lose elevation even after cleaning and reinstalling the release valve:

- Outlet check valve requires cleaning: Remove and clean the outlet check valve assembly (items #229-232 in FIG. 1; items # 236-239 in FIG. 2). Follow steps 3 through 8 of the "Release Valve Removal & Cleaning Procedure" above;
- Trapped air might be present in the cylinder.

Air Removal Procedure:

1. Unload the cart;
2. Raise the deck slightly (approx 5-6 inches);
3. Turn the release knob counterclockwise to lower the deck;
4. With the release knob held open, pump the pedal a few times;
5. Turn the release knob clockwise until it is snug;
6. Pump the pedal until the deck has elevated to approx 5-6 inches;
7. Again lower the deck while performing steps 4, 5 & 6.

Steps 1-7 should purge air from the system.

Inspections & Maintenance:

Only trained and authorized persons should maintain, repair, adjust and inspect the scissor lift cart. Maintenance and inspection personnel should verify that the cart complies with all regulations, codes, and standards that apply to Industrial Scissors Lifts in the location where the cart is used. The person(s) designated to conduct inspections **by your employer** must inspect the cart BEFORE it is used for the first time and prior to EACH use thereafter.

Maintenance Props: Use two (one for each side) pieces of 1in. x 1in. timber or two sections of square bar (at least 1in on a side) as maintenance props. Proper maintenance prop placement is illustrated in FIG. 10 below. Fully raise the deck; then insert the props between each roller and the front of the frame. Lower the deck until the rollers firmly contact the props and the deck stops descending.

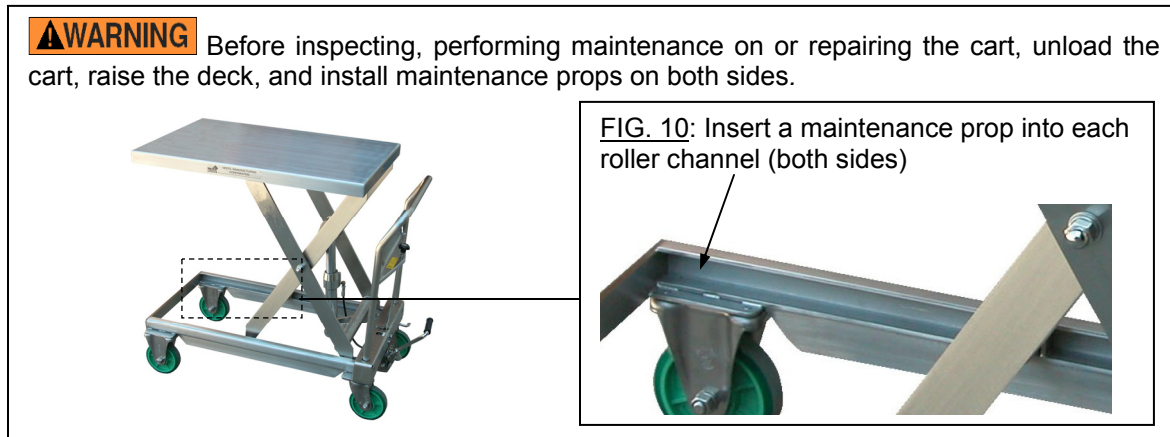

After maintenance/repair work is complete, fully raise the deck, and then remove the props.

Inspections:

(A) Inspect daily for:

- 1.) Oil leaks from the hydraulic system;
- 2.) Pinched or chafed hydraulic lines;
- 3.) Damage to or structural deformation of:
 - scissor leg weldments, pins, rollers, leg brackets (that connect legs to deck or frame), and all fastening hardware;
 - cylinder or cylinder retention brackets;
 - frame weldment;
 - castors;
- 4.) Unusual noise or binding, or evidence thereof;
- 5.) Labels affixed to the cart.

(B) Inspect monthly for:

- 1.) Oil level ($\frac{1}{2}$ " below the fill hole in the reservoir with the deck fully lowered);
- 2.) Oil leaks;
- 3.) Worn or damaged hydraulic hoses;
- 4.) Pivot point wear;
- 5.) Roller looseness and wear;
- 6.) Integrity of the retaining hardware on all rollers and on all pivot point pins.
- 7.) Looseness, wear, or damage to the caster bearings and/or mounting hardware.
- 8.) Unusual noises.
- 9.) All the information, safety, and warning labels being in place and in good condition.
- 10.) Dirt and debris on the deck, in the roller channels, on the scissor legs.

(C) Yearly inspection:

Change the oil if it darkens, becomes gritty, or turns a milky color (caused by water). Replace the contaminated oil with 150 SUS at 100°F (ISO 32 at 40°C) viscosity grade anti-wear hydraulic oil, such as AW 32 or HO 150 hydraulic oil, or a non-synthetic transmission fluid. You may use a synthetic transmission fluid if you flush the system with the synthetic fluid before filling the reservoir.

⚠ WARNING DO NOT use a cart that is structurally damaged in any way. Structural damage includes, but is not limited to, bending, warping, cracking or other deformation of one or more of the scissor legs, the frame, rollers, or the deck. Restore the cart to normal operating condition BEFORE using it again.

NOTICE DO NOT use brake fluid or jack oils in the hydraulic system. If oil is needed, use an anti-wear hydraulic oil with a viscosity grade of 150 SUS at 100°F, (ISO 32 cSt @ 40°C), or Dexron transmission fluid.

Troubleshooting:

Problem	Possible Causes	Action
Deck does not elevate	<ul style="list-style-type: none"> a. Load weight exceeds lifting capacity b. relief valve set too low 	<ul style="list-style-type: none"> a. Remove load and use another cart with greater lifting capacity b. remove part of the load c. load cart with rated load, increase the relief-valve setting until the rated load will rise.
Deck rises when the pedal is pressed down but lowers when the pedal is returned to the raised position	<ul style="list-style-type: none"> a. inlet check-valve is leaking 	<ul style="list-style-type: none"> a. clean ball and seat
Spongy or jerky deck movement	<ul style="list-style-type: none"> a. Excessive air in cylinder b. debris in roller channel(s) c. hydraulic oil level low 	<ul style="list-style-type: none"> a. Bleed air as described in this manual (see "Air Removal Procedure" on p. 12). b. inspect rollers, clean channels c. add oil to within ½" of the top of the reservoir
Deck lowers too quickly	<ul style="list-style-type: none"> a. release-valve opened too far. 	<ul style="list-style-type: none"> a. Do not over-tighten; open slowly
Platform lowers too slow	<ul style="list-style-type: none"> a. pinched hose b. foreign matter in one or more roller channels c. Velocity fuse locking up 	<ul style="list-style-type: none"> a. check hose for kinks or chaffing b. clean roller channels c. bleed air from system (see "Air Removal Procedure" on p. 12).
Deck rises when the pump pedal is pressed down but will not lower	<ul style="list-style-type: none"> a. scissor legs binding b. scissor legs bent c. release rod not connected to release-valve 	<ul style="list-style-type: none"> a. lubricate pivot points b. replace bent components c. repair as necessary

Label placement diagram:

Only use the lifter if ALL labels are readable and undamaged. Contact us for replacement labels if necessary, and DO NOT use the lifter until all replacement labels are affixed to the device.

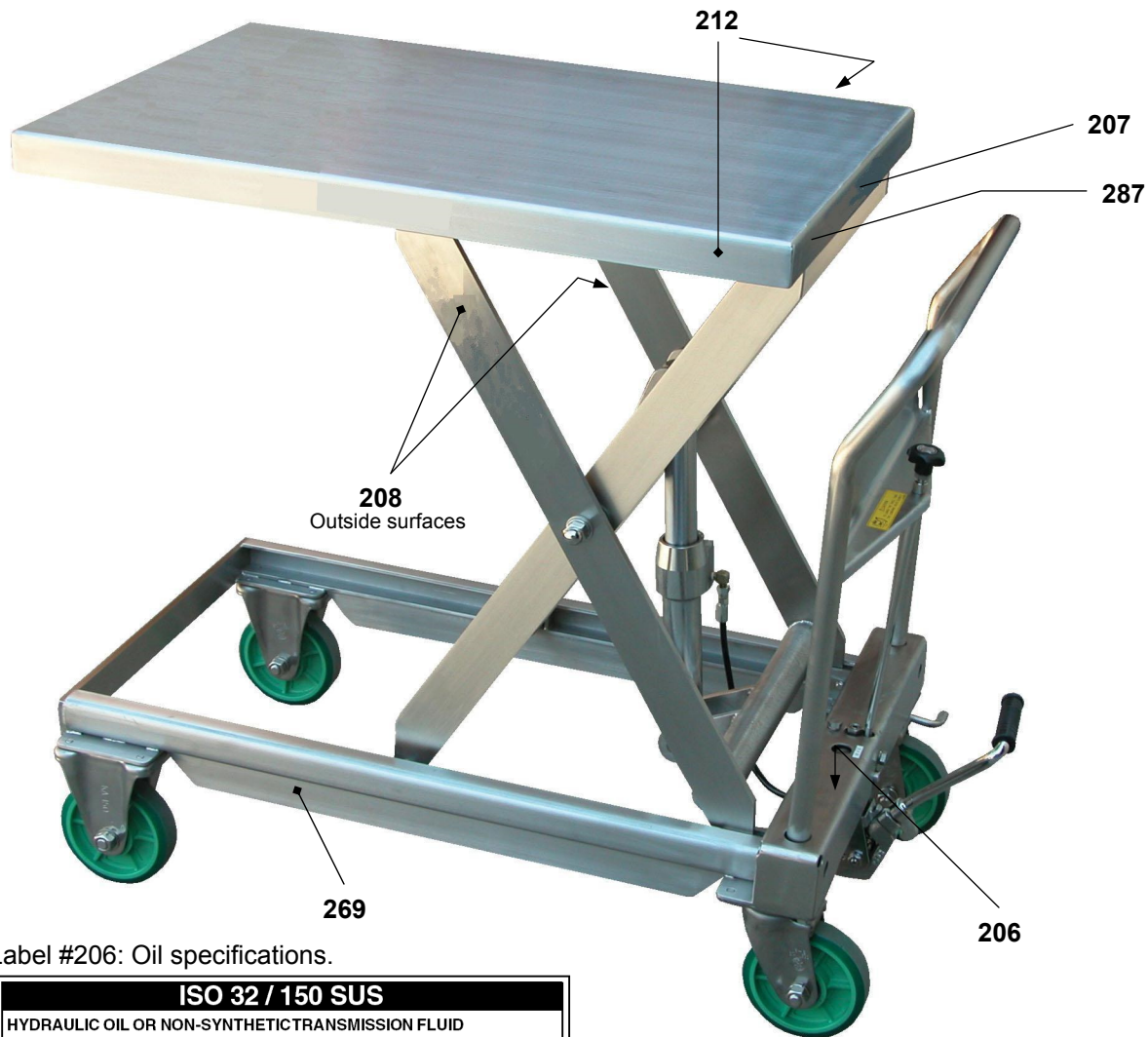

Label #206: Oil specifications.

ISO 32 / 150 SUS	
HYDRAULIC OIL OR NON-SYNTHETIC TRANSMISSION FLUID	
ACEITE HIDRAULICO O LIQUIDOS DE TRANSMISION NO SINTETICOS	
HUILE OU LIQUIDE HYDRAULIQUE NON-SYNTHEIQUE	
<small>206 Rev 1003</small>	
<small>VESTIL MANUFACTURING CORPORATION • Phone (260) 665-7586 • www.vestil.com</small>	

Label #212:

⚠ WARNING	⚠ ADVERTENCIA	⚠ AVERTISSEMENT
LOCK CASTER when loading and unloading	PONGA EL FRENO el la rueda cuando se cargue y descargue	VERROUILLER LA ROULETTE en chargeant et decharger
<small>Vestil Manufacturing Corporation • Angola, Indiana USA • Phone (260) 665-7586 • www.vestil.com 212 Rev 0988</small>		

Label #208: The scissor legs create pinch points as the deck rises and lowers.

⚠ WARNING	⚠ ADVERTENCIA	⚠ AVERTISSEMENT
KEEP CLEAR OF PINCH POINT	MANTENGASE ALEJADO DEL PUNTO DE CORTE	SE TENIR À DISTANCE DU POINT DE PINCEMENT
<small>VESTIL MANUFACTURING CORPORATION • Phone (260) 665-7586 • Fax (260) 665-1339 • sales@vestil.com • www.vestil.com 208 Rev 0988</small>		

Label #287: Product capacity label

MODEL/MODÉLO/MODÈLE _____
CAPACITY _____ lbs.
CAPACIDAD/CAPACITÉ _____ kgs.
SERIAL/SERIE/SÉRIE _____
VESTIL MANUFACTURING CORPORATION
sales@vestil.com • www.vestil.com
<small>287 REV 0988</small>

Label #269: "Install both maintenance props..."

⚠ WARNING	⚠ ADVERTENCIA	⚠ AVERTISSEMENT
INSTALL BOTH MAINTENANCE STOPS before working under this table. DO NOT use maintenance stops with table loaded.	INSTALE AMBOS TOPES DE MANTENIMIENTO antes de trabajar debajo de esta mesa. NO use los topes de mantenimiento con la mesa cargada.	INSTALLER LES DEUX BUTOIRS D'ENTRETIEN avant de travailler sous cette table. NE PAS utiliser les butoirs d'entretien quand la table est chargée.
<small>VESTIL MANUFACTURING CORPORATION, Angola, IN 46703 USA, Phone (260) 665-7586 • www.vestil.com 269 Rev 0885</small>		

Label #207: "Read Owner's manual"; "Do not put hands, feet... under top"; "Do not work under lift without safety block"; "Do not sit, stand, or ride on lift."

<p>⚠ WARNING</p> <p>TO AVOID PERSONAL INJURY READ OWNER'S MANUAL BEFORE OPERATING OR REPAIRING SCISSORLIFT.</p>	<p>⚠ ADVERTENCIA</p> <p>PARA EVITAR DAÑOS PERSONALES LEA EL MANUAL DEL PROPIETARIO ANTES DE OPERAR O REPARAR EL ELEVADOR.</p>	<p>⚠ AVERTISSEMENT</p> <p>POUR ÉVITER TOUTE BLESSURE PERSONNELLE LIRE LE MANUEL D'UTILISATION AVANT DE METTRE EN MARCHÉ OU AVANT DE RÉPARER L'ÉLEVATEUR CRESSAU.</p>	<p>DO NOT PUT HANDS, FEET OR OBJECTS UNDER TOP / LOWER PLATFORM(S) / CHASSIS.</p> <p>NO ponga manos pies u objetos debajo del soporte, debajo de la plataforma o chasis.</p> <p>NE PAS METTRE LES MAINS, LES PIEDS OU TOUT OBJET SOUS LE PLATAU SUPÉRIEUR / DESSOUS LA PLATE-FORME SUPÉRIEURE.</p>	<p>DO NOT WORK UNDERLIFT WITHOUT SAFETY BLOCK OR WHILE LOADED. KEEP CLEAR OF MOVING SCISSORLIFT MECHANISM.</p> <p>NO TRABAJE DEBAJO DEL ELEVADOR SIN LOS FRENSOS DE SEGURIDAD O CUANDO ESTÉ CARGADO. MANTÉNGASE ALEJADO DEL MECANISMO DE TRABAJO EN MOVIMIENTO.</p> <p>NE PAS TRAVAILLER SOUS L'ÉLEVATEUR SANS BLOC DE SÉCURITÉ OU LORSQU'IL EST CHARGÉ. RESTER À L'ÉCART DU MÉCANISME CRESSAU LORSQUE L'ÉLEVATEUR EST EN FONCTIONNEMENT.</p>	<p>DO NOT STAND, SIT OR RIDE ON LIFT.</p> <p>NO SE SIENTE, SEPARE O VAYA EN EL ELEVADOR.</p> <p>NE PAS SE TENIR DEBOUT, S'ASSEoir OU MONTER SUR L'ÉLEVATEUR.</p>
<small>207 Rev 0988</small>					

LIMITED WARRANTY

The manufacturer warrants this product to be free of defects in material and workmanship during the warranty period. *Our warranty obligation is to provide a replacement for a defective original part if the part is covered by the warranty, after we receive a proper request from the warrantee (you) for warranty service.*

Who may request service?

Only a warrantee may request service. *You are a warrantee if you purchased the product from the manufacturer or from an authorized distributor.*

What is an “original part”?

An original part is a part *used to make the product as shipped* to the warrantee.

What is a “proper request”?

A request for warranty service is proper if we receives: 1) a photocopy of the Customer Invoice that displays the shipping date; AND 2) a written request for warranty service including your name and phone number. Send requests by any of the following methods:

In the written request, list the parts believed to be defective and include the address where replacements should be delivered.

What is covered under the warranty?

After we receives your request for warranty service, an authorized representative will contact you to determine whether your claim is covered by the warranty. Before providing warranty service, we may require you to send the entire product, or just the defective part or parts, to its facility in Angola, IN. The warranty covers defects in the following original/ dynamic components: motors, hydraulic pumps, electronic controllers, switches and cylinders. It also covers defects in original parts that wear under normal usage conditions (“wearing parts”), such as bearings, hoses, wheels, seals, brushes, and batteries.

How long is the warranty period?

The warranty period for original components is 90 days. The warranty period begins on the date when we ship the product to the warrantee. If the product was purchased from an authorized distributor, the period begins when the distributor ships the product. We may extend the warranty period for products shipped from authorized distributors by *up to 30 days* to account for shipping time.

If a defective part is covered by the warranty, what will the company do to correct the problem?

We will provide an appropriate replacement for any *covered* part.

What is not covered by the warranty?

1. Labor;
2. Freight;
3. Occurrence of any of the following, which automatically voids the warranty:
 - Product misuse;
 - Negligent operation or repair;
 - Corrosion or use in corrosive conditions;
 - Inadequate or improper maintenance;
 - Damage sustained during shipping;
 - Accidents involving the product;
 - Unauthorized modifications: DO NOT modify the product IN ANY WAY without first receiving written authorization from the Manufacturer. Modification(s) might make the product unsafe to use or might cause excessive and/or abnormal wear.

Do any other warranties apply to the product?

The Manufacturer makes no other express warranties. All implied warranties are disclaimed to the extent allowed by law. Any implied warranty not disclaimed is limited in scope to the terms of this Limited Warranty.