

ALUMINUM PICK-UP/VAN RAMP-RAMP-5077

APPROX WEIGHT: 35.71 lbs.
 DOES NOT INCLUDE WEIGHT OF POWER OR PACKAGING!!!

*** ANY ADDITIONS, DELETIONS, OR OMISSIONS MUST BE CORRECTED ON THIS DRAWING AS THIS DRAWING WILL BE CONSIDERED ALL INCLUSIVE ***
 ALL GRAPHICS PROVIDED ARE FOR REFERENCE ONLY. IF CERTAIN DIMENSIONS ARE CRITICAL PLEASE VERIFY THOSE DIMENSIONS WITH YOUR SALESPERSON

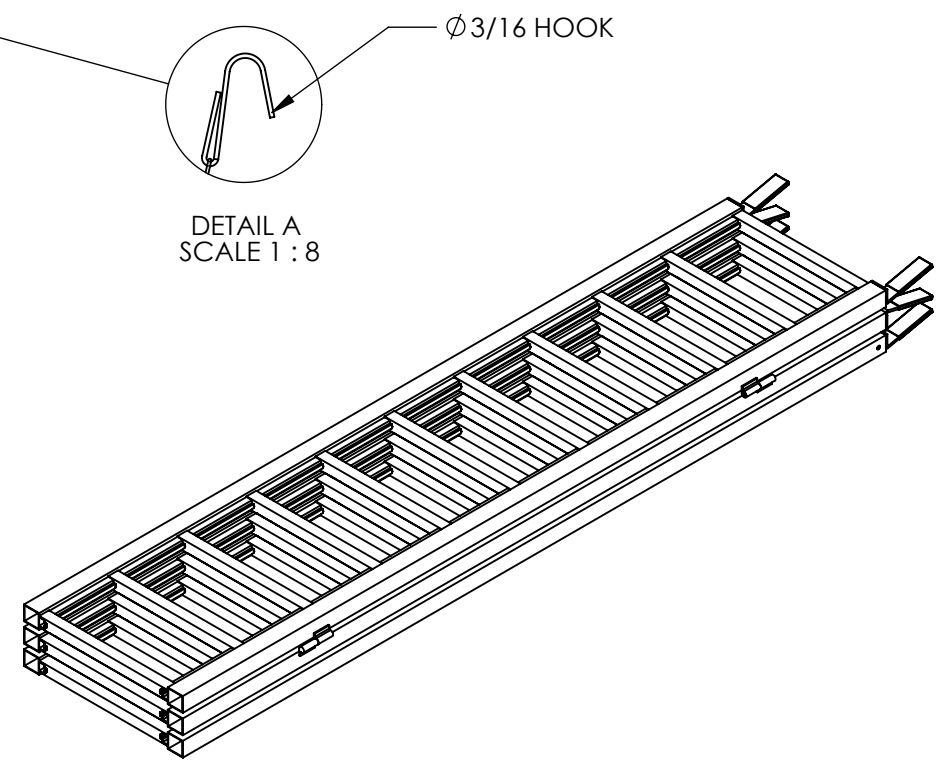
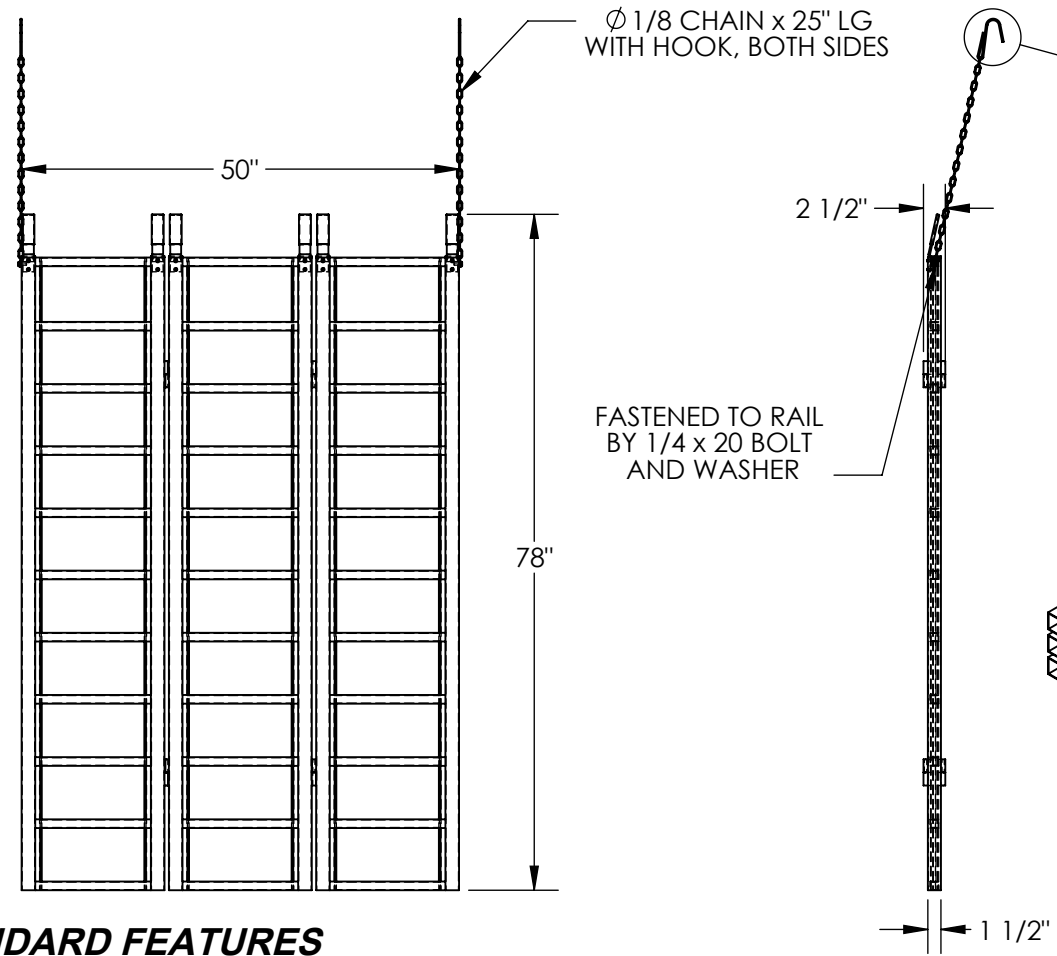

DIMENSION TOLERANCE $\pm 1/4$ "

STANDARD FEATURES

- MODEL NUMBER IS RAMP-5077
- OVERALL THICKNESS IS 2 1/2"
- USABLE THICKNESS IS 1 1/2"
- OVERALL WIDTH IS 50"
- USABLE WIDTH IS 50"
- OVERALL LENGTH IS 78"
- MAX CAPACITY IS 1,500 LBS
- MATERIAL IS ALUMINUM

SPECIAL FEATURES

NONE

APPROVAL

I, THE UNDERSIGNED, AGREE THAT THE PRODUCT AS REPRESENTED SATISFIES DESIGN AND DIMENSION REQUIREMENTS. I ALSO ACKNOWLEDGE MY DUTY TO CONFIRM PRODUCT AND INSTALLATION COMPLIANCE WITH ALL APPLICABLE FEDERAL, STATE AND LOCAL REGULATIONS AND STANDARDS.
ALL SPECIAL UNITS ARE NON-RETURNABLE
 As drawn As marked

Signed: _____ Date: _____

LEAD TIME WILL START UPON RECEIPT OF SIGNED APPROVAL DRAWING

DISTRIBUTOR'S NAME:		P.O.#	X
		W.O.#	X
DRAWN BY:	NS	DATE:	1/2/13
REFERENCE:	X	SCALE:	1:22
QUOTED LEAD TIME:	X	QUOTE #	X
		FILE NAME:	18-007-289