

DWG NO: VENT-H ASSY

LOCATION: C:\TROY

MODEL: VENT-H ASSY

WEIGHT:

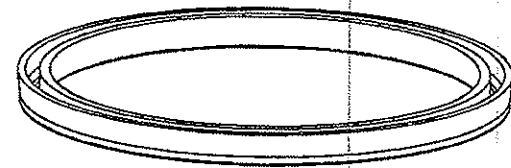
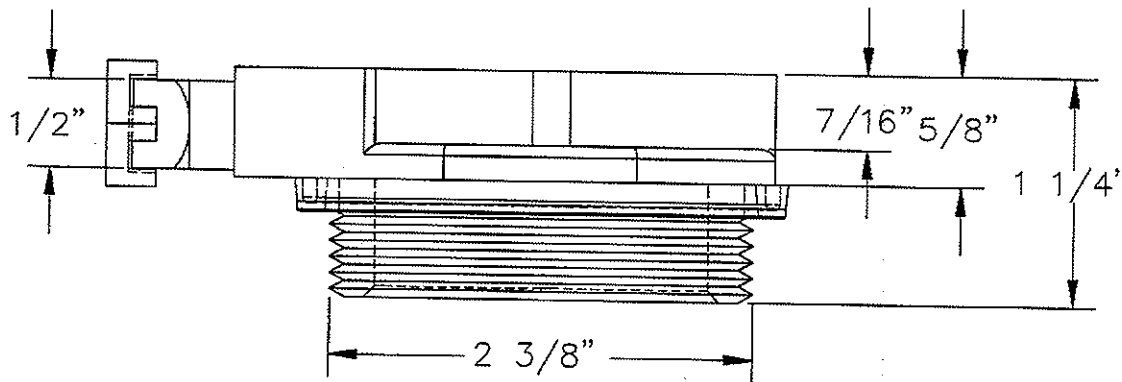
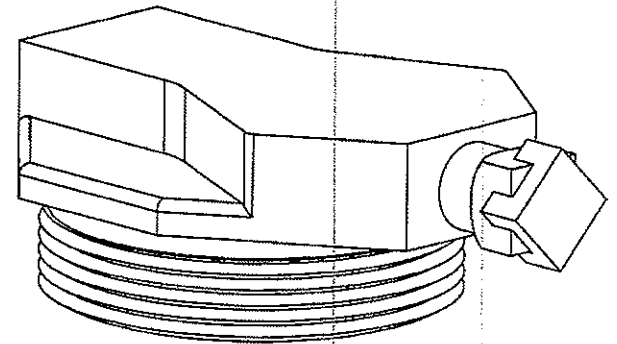
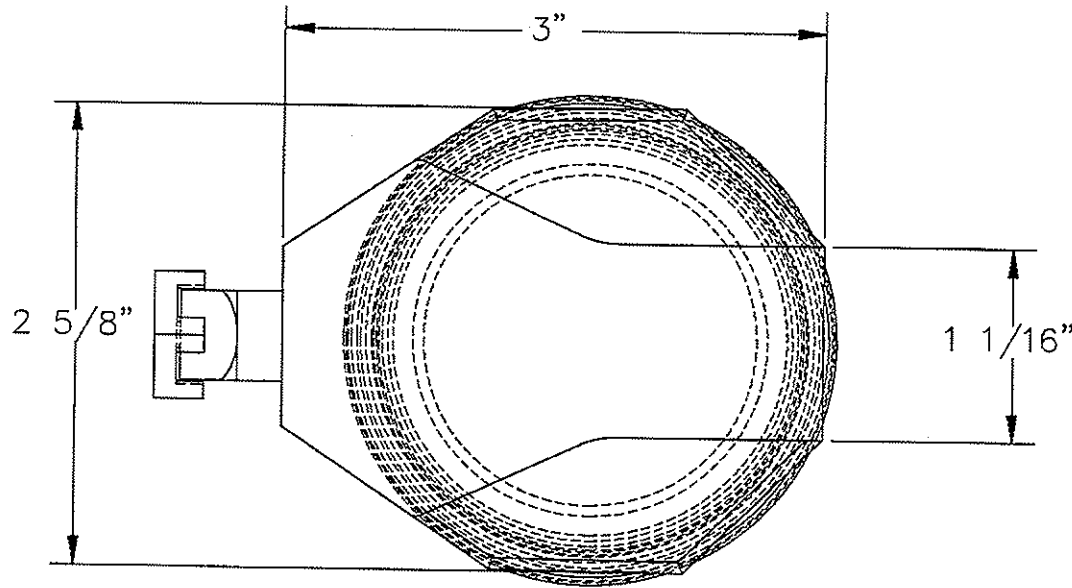

UNLESS OTHERWISE SPECIFIED:					
REMOVE ALL BURRS AND SHARP EDGES					
DIMENSIONS ARE IN INCHES			DESCRIPTION:		
CONCENTRIC	.006 TIR	.060 TIR	ASSEMBLY, VENT-H		
ANGLES	± 0° 30'	± 1° 0'	MODEL NO: VENT-H		
	X.XXX ± .005		DRAWN BY:	DATE:	
	X.XX ± .010		T.NEJENSCH	08/18/06	SCALE: 1:1
DECIMALS	X.X ± .025	± .015	CHECKED BY:	DATE:	SHEET 1 OF 1
FRACTIONS	± 1/32	± 1/16			SIZE <b>A</b>
TOLERANCES	MACHINE	WELDMENT	MATERIAL		REV
COMMENTS:	DWG. NO. <b>VENT-H ASSY</b>				
DO NOT SCALE DRAWING					

5

4

3

2

1