

A company dedicated to solving loading dock and material handling problems since 1955.

Loading Dock Solutions

OWNER'S MANUAL

EDGE-O-DOCK • MODEL FM / PP / PE

Contents

Warnings and Safety Instructions	1	Spring Adjusting Instructions (FM Series)	6
Receiving Instructions	1	PE Hydraulic & Troubleshooting Guide	7
Loading Instructions	2	Exploded Parts Drawing (FM Series)	9
Unpacking and Handling Instructions	2	Parts List (FM Series)	10
Operating Instructions	2	Exploded Parts Drawing (PP & PE)	11
Installation Instructions	3-5	Parts List	11
Electrical Schematic	6	Warning Label Identification	12
Power Unit Exploded Parts Drawing	8	Limited Warranty/Service Record	13

WARNINGS & SAFETY INSTRUCTIONS

Read owner's manual completely before operating unit!

- Read and understand the owner's manual before using or servicing the leveler.
- The lip plate should be secured outward before any work is preformed on the leveler.
- Ensure that the safety and warning labels stay in place and are legible. See the labels page in this manual.
- The Edge-O-Dock leveler must be securely welded and anchored to the dock face. See the installation instructions.
- Do not use the leveler if any damage or unusual noise is observed.
- Always watch the leveler carefully when it is in operation.
- Be sure nothing is on the top of the leveler before operating it.
- Do not perform any modifications to the leveler without the manufacturer's approval. Failure to receive authorization for changes to the equipment could void the warranty.
- Maintenance and repairs are to be performed only by personnel qualified to perform the required work.
- Do not use brake fluid or jack oils in the hydraulic system. If oil is needed, use an antiwear hydraulic fluid with an SUS viscosity of 150 - 200 at 100°F, (SAE viscosity grade 32), or Dexron transmission fluid.
- Use only replacement parts either supplied or approved by the manufacturer.

RECEIVING INSTRUCTIONS

Every unit is thoroughly tested and inspected prior to shipment. However, it is possible that the unit may incur damage during transit. If you see damage when unloading, make a note of it on the BILL OF LADING.

Remove all packing and strapping material, inspect for damage. IF DAMAGE IS EVIDENT, FILE A CLAIM WITH THE CARRIER IMMEDIATELY! Also, check the unit size, type of power unit, etc., to see that the unit is correct for the intended application.

MODEL NUMBER AND CAPACITIES

The model number, serial number and capacities are inscribed on the nameplate. Please remember to include these numbers in any correspondence with your dealer or the factory.

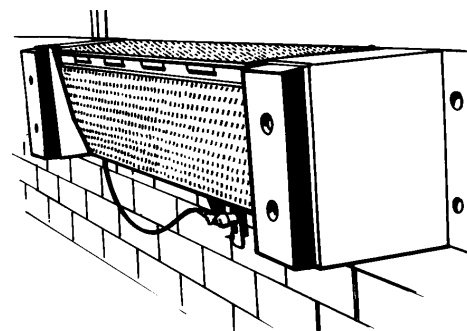

**EDGE-O-DOCK
FM / PP / PE SERIES**

LOADING INSTRUCTIONS

The load capacity rating as inscribed on the nameplate of your unit designates its net capacity. This capacity must never be exceeded, as permanent damage or personnel injury may result.

UNPACKING AND HANDLING INSTRUCTIONS

CAUTION

- Read instructions completely before adjusting.
- Follow instructions carefully.
- Use end wrench, not crescent wrench, as crescent may slip.
- Recommended unpacking and handling is shown below.
Recommended dock height is 50".
Service range is +5" to -5".

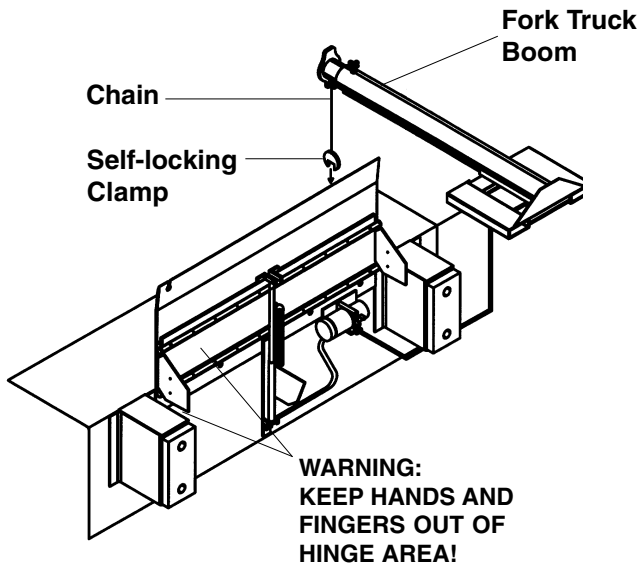

OPERATING INSTRUCTIONS

- I.) Back trailer slowly against Edge-O-Dock bumpers. Turn off the engine and set the emergency brake on truck. Position wheel chocks (by others) per OSHA requirements to prevent trailer movement.
- II.) Follow the instructions below according to the model of Edge-O-Dock you have.

Mechanical Operation • Series FM

- 1.) Remove the lever from right side of bumper box and insert it into the socket of the back plate (the socket is on right hand side).
- 2.) Pull the handle back until the leveler plate is fully extended and leaning back towards the ramp.
- 3.) Push the handle forward to allow the lip plate to extend and fall on the bed of the trailer. Do not operate without a truck in place as the operator may lose balance.
- 4.) Remove the lever and place it in the bumper box.
- 5.) When loading and unloading is complete, remove chocks and allow trailer to pull away. The Edge-O-Dock will return to its original position.

Hand Pump Operation • Series PP

- 1.) Rotate the valve on the pump clockwise to close the fluid return valve. Raise the dockleveler with the hand pump. When the dockleveler clears the trailer bed and fully extends, open the return valve to allow the lip to settle on the trailer bed. *Be sure to leave the fluid return valve open to allow the dockleveler to float with the trailer.*
- 2.) When loading/unloading is complete, remove the chocks and allow the trailer to pull away. The Edge-O-Dock will return to its original position.

Electric Operation • Series PE

- 1.) Push "**RAISE**" button on control box. The dockleveler will begin to rise. When the dockleveler lip reaches full extension, release the button. It will lower and settle on the trailer bed.
- 2.) When loading/unloading is complete, remove the chocks and allow the trailer to pull away. The Edge-O-Dock will return to its original position.

Ordering Replacement or Extra Parts

Our company takes pride in using the finest available parts for our equipment. We are not responsible for equipment failure resulting from the use of unapproved replacement parts. To order replacement or extra parts for your equipment contact Customer Service at the factory. In any correspondence with the factory please include the Serial Number which is inscribed on the nameplate of the piece of equipment. Use only the part numbers provided in this Owner's Manual. Please indicate the motor phase and voltage that the equipment is operating on.

INSTALLATION INSTRUCTIONS

(READ ALL INSTRUCTIONS BEFORE PROCEEDING!)

Dock Edge Construction

The procedure for the installation of the Edge-O-Dock dockleveler varies with the dock edge construction and the height differential. The recommended dock edge for installing an Edge-O-Dock unit is a well anchored six inch channel. With a six inch channel embedded in to the dock edge, the installer can weld the ramp and bumper blocks securely into position. The ramp and blocks cannot be welded into position if the dock edge steel is less than six inches. For installations with less than six inches of steel edging a combination of anchor bolts and welding is required. If the dock has no steel edging, a steel plate must be anchored to the floor to provide a surface to weld the ramp to in order to maintain the capacity of the leveler. **Failure to follow the proper installation procedure will decrease capacity of dockleveler.**

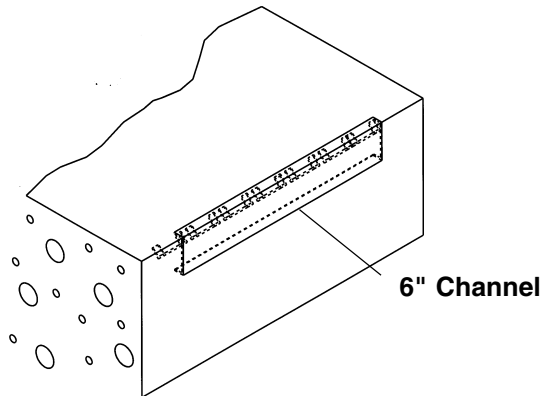

Recommended dock edge for new construction

The recommended dock edge for new construction is a well anchored 6 inch channel (8.2 lb. minimum). Concrete "J" anchors shall be 1½ inches wide with a length of 6 inches plus 1½ inches bent at 90 degrees on the end. Minimum material thickness shall be ¼ inch. One anchor shall be installed every 12 inches.

Height Differential

The optimum dock height in most cases is 50". On dock heights significantly different than 50", ramps and ramp support angles as shown below must be employed.

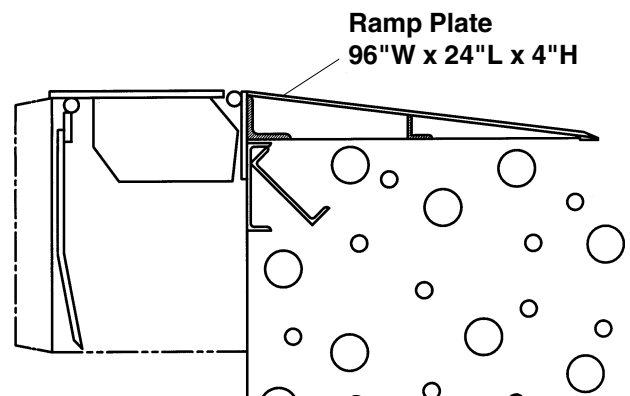
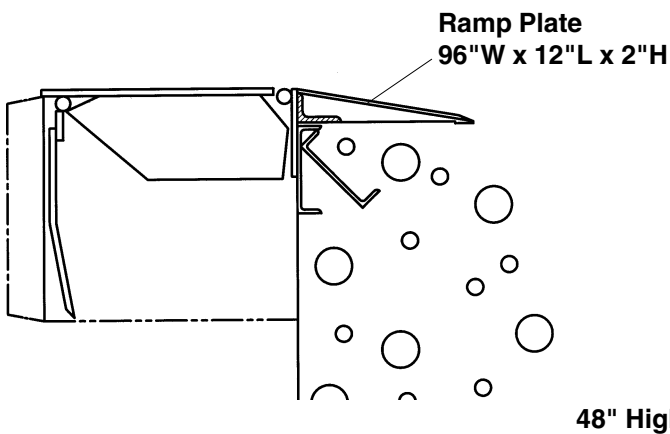

Linkage Installation Instructions

FOR MECHANICAL EDGE-O-DOCK

- 1.) Remove the cotter pin from the clevis pin.
- 2.) Remove the clevis pin from the linkage arms.
- 3.) Move the lip plate down until the hole in the mounting bracket is aligned with the holes in the link arms.
- 4.) Insert the clevis pin through the aligned holes and fasten with the cotter pin.

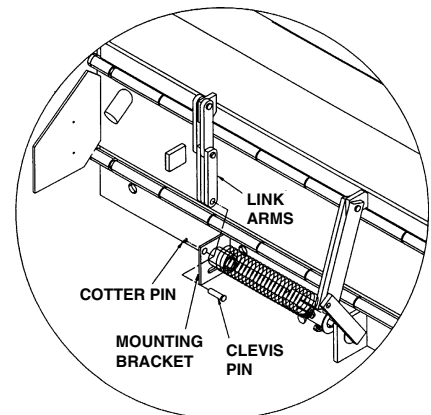

INSTALLATION OF EDGE-O-DOCK • FM SERIES

Installation procedure for loading dock with steel edge 6in. or greater

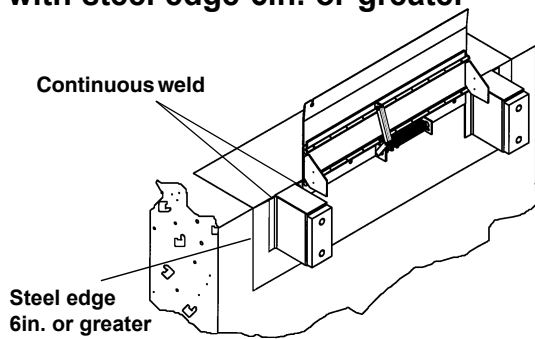

1. Remove all material and protrusions from the face of the dock.
2. Center the ramp in the doorway and tack weld at each end. Be certain the mounting plate does not extend above the edge of dock.
3. Continuously weld the mounting plate to the steel dock edge.
4. Weld bumper blocks on each side of ramp. Weld continuously across tops and down both sides.

Installation procedure for loading dock with steel edge less than 6in.

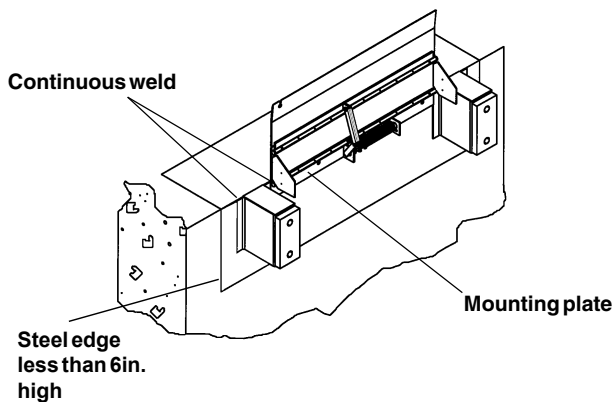

1. Remove all material and protrusions from the face of the dock.
2. Center the ramp in the doorway and tack weld at the end. Be certain the mounting plate does not extend above the edge of the dock.
3. Continuously weld the mounting plate to the steel dock edge.
4. Weld bumper blocks on each side of ramp. Weld continuously across top and down both sides.
5. Install one lag bolt 5/8" x 5" on the outside and inside flanges of each bumper block.
6. Install at least two lag screws 3/4" x 5" along the bottom of the mounting plate. Install four if the concrete is flaky or steel is not rigid.

Installation procedure for docks without steel edges

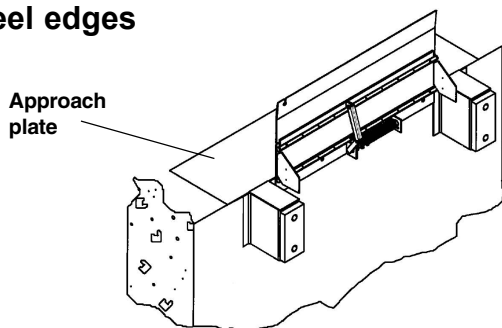

1. Remove all material and protrusions from the face of dock.
2. In installations where cartons or pallets are slid along the building floor into the truck, the approach plate must be recessed into a groove in the floor.
3. To install the groove, locate and mark the center of the dock where ramp is to be mounted. Make a centered chalk line 1/2 inch longer than ramp plate, 12 inches back from the face of the dock.
4. Using a SKIL ROTO Hammer No. 736, or similar tool, cut a groove 3/8" deep x 2" wide x ramp length plus 1/2 inch on the outside of the line. (The groove will start 10" from the dock face and end 12" from dock face.)
5. Position the beveled and turned-down edge of approach plate in the groove with opposite edge flush with the dock edge.
6. Anchor the plate to floor with four 5/8" x 5" lag bolts. Do not tighten yet.
7. Center the mounting plate of leveler against the approach plate anchored to floor. Tack weld the mounting plate in place.
8. Continuously weld across the top. Chip and grind as required.
9. Drill holes into the dock through the holes in the mounting plate. Depending on the cement condition, up to 8 may be required.
10. Install anchors and bolts. Do not tighten.
11. Install bumper blocks on each side of ramp mounting plate. Weld the top of the bumper blocks to the ramp plate, and the side of the bumper blocks to the ramp mounting plate. Install two anchors on each side of bumper blocks.
12. Tighten the anchor bolts on the face of the dock, then on top of dock.
13. Weld and round-off (with grinder) the lag bolts on the ramp plate.

INSTALLATION OF EDGE-O-DOCK PE AND PP SERIES

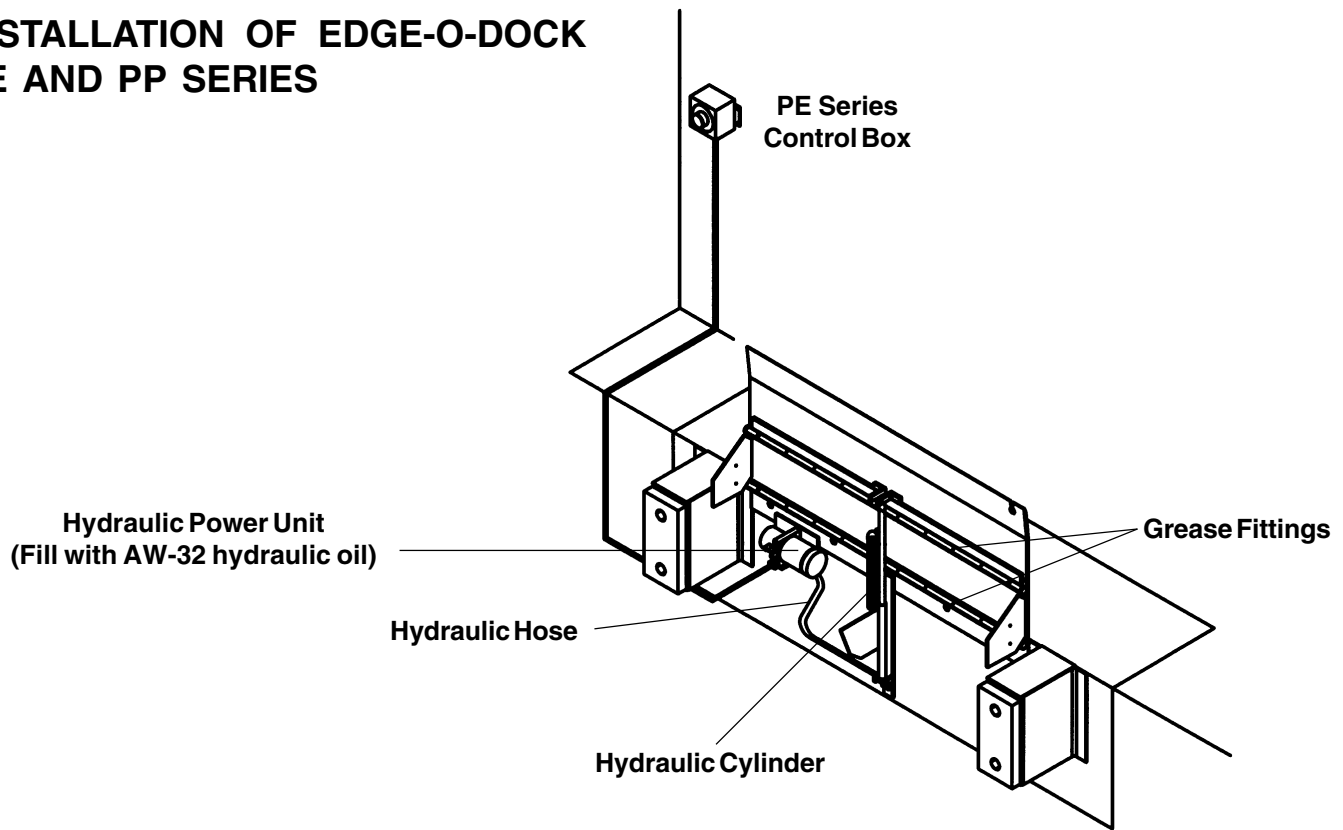

Installation of PP Series

1. Install the PP leveler and bumpers per the preceding instructions.
2. Install the cylinder with the supplied parts (rod end up) at bottom only. Keep the cylinder closed (piston retracted).
3. Mount the hand pump adjacent to the leveler on a post or wall. Drill a hole thru the wall for hydraulic hose.
4. Attach the hydraulic line to the pump, run to the cylinder and loosely attach to the cylinder.
5. Fill the pump reservoir with the oil. Pump oil into line. Continue pumping slowly until air ceases to escape from cylinder.
6. Tighten fitting on cylinder and continue pumping until cylinder extends enough to attach to top bracket. Attach cylinder.

Installation of PE Series

1. Install the PE leveler and bumpers per preceding instructions.
2. Install the cylinder with the supplied parts (rod end up).
3. Remove the shipping plug in the reservoir and install the breather vent.
4. Mount the control box on the inside wall of the building at a convenient height. Drill a hole through the wall for 1/2" conduit. Run the conduit from the hydraulic pump motor, below the bumper, and up through the hole previously drilled.
5. Follow standard electrical procedures and all applicable codes when installing the control box to the hydraulic unit (See electrical the schematic on page 6).
6. Check the operation of the leveler. Push the **RAISE** button and hold it in until the cylinder is fully extended. Release the button and the leveler should descend to a work position. If the leveler fails to operate, check the electrical connections to verify proper connections, power source on, and fuses installed and functioning. Operate at least 6 full cycles.
7. Grease all hinge fittings at the time of installation and every 3 months thereafter.

ELECTRICAL CIRCUIT DIAGRAM

BE SURE ALL POWER IS OFF BEFORE ATTEMPTING TO WORK ON THIS EQUIPMENT!
CAUTION: SERVICE WORK SHOULD BE PERFORMED ONLY BY TRAINED & QUALIFIED PERSONNEL

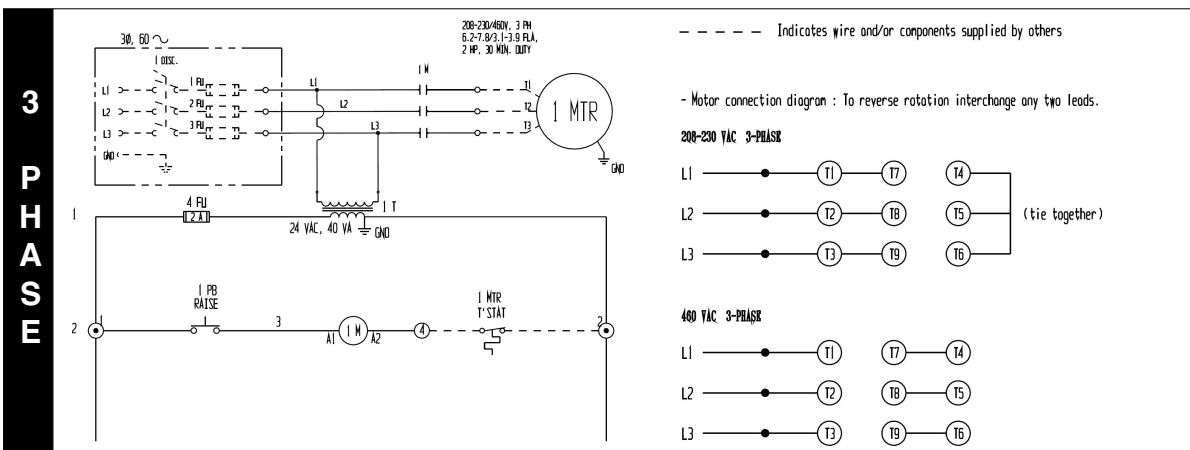
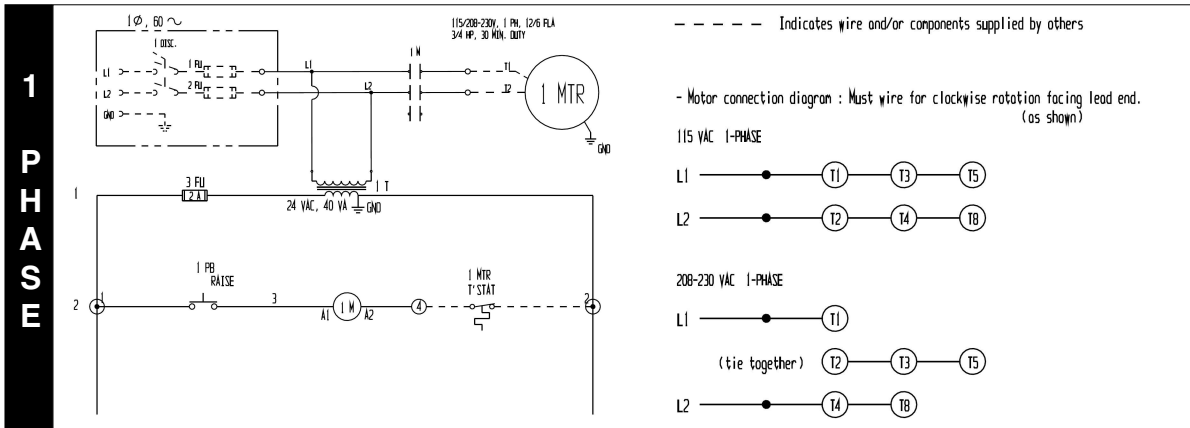

MECHANICAL EDGE-O-DOCK ADJUSTING INSTRUCTIONS

1.) Stand on the ground in front of the leveler. Raise the leveler to the vertical position. Place the forks of your lift truck under lip to hold lip out at nearly level position. Never work directly under lift truck forks.

2.) To adjust the force that counterbalances the leveler, use the pipe lever ("handle" no., 16 on p. 9) supplied with the dockleveler and a 3/4" open end wrench or socket. Place the open end of the pipe over the stem on the spring winding tube. We recommend that one person rotate the winding tube with the pipe to the desired strength and a second person tighten the 3/4" bolts onto the milled flats (of the interior bar).

3.) When the required lifting torsion is achieved, return to leveler to normal operating position. Check the adjustments. If the leveler still does not raise properly, repeat the previous steps to either increase or decrease spring lifting torsion. If the leveler bounces or floats when the lip is extended there is too much lifting torsion. Reverse the process described in step 2 to reduce spring tension.

4.) In order for the ramp plate to automatically remain under spring tension in the vertical position (when the deck plate is raised), it might be necessary to adjust the position of the cylinder bracket. Install a 3/4in. UNC x 2in. bolt through the opening at the base of the bracket (see FIGS. 2A & 2B). Wind the bolt through the nut welded onto the back side of the bracket. As the end of the bolt presses against the loading dock wall, the bracket position changes. After installing the bolt, raise the leveler. If the ramp plate still does not snap to a vertical position, lower the leveler and turn the bolt farther.

NOTE: This is an excellent time to lubricate the grease zerks on the hinges. A standard grease gun will service these. This must be done regularly (at least once per month) for ease of operation and maintenance.

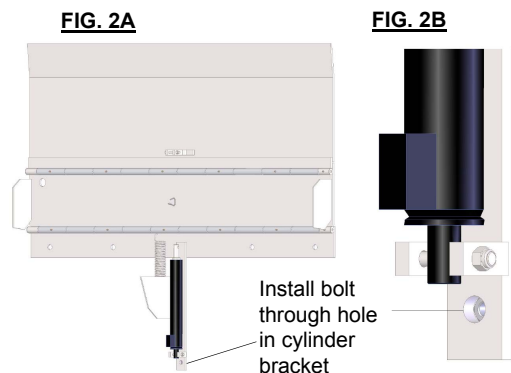
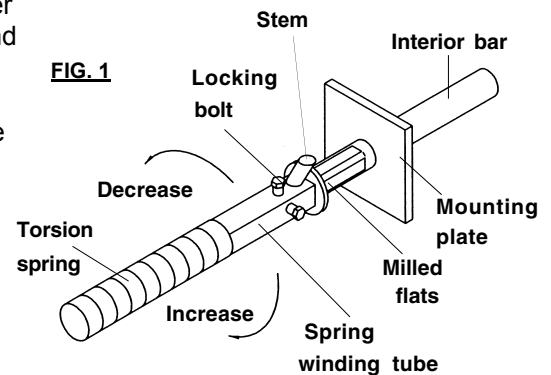

POWER UNIT ASSEMBLY, PE

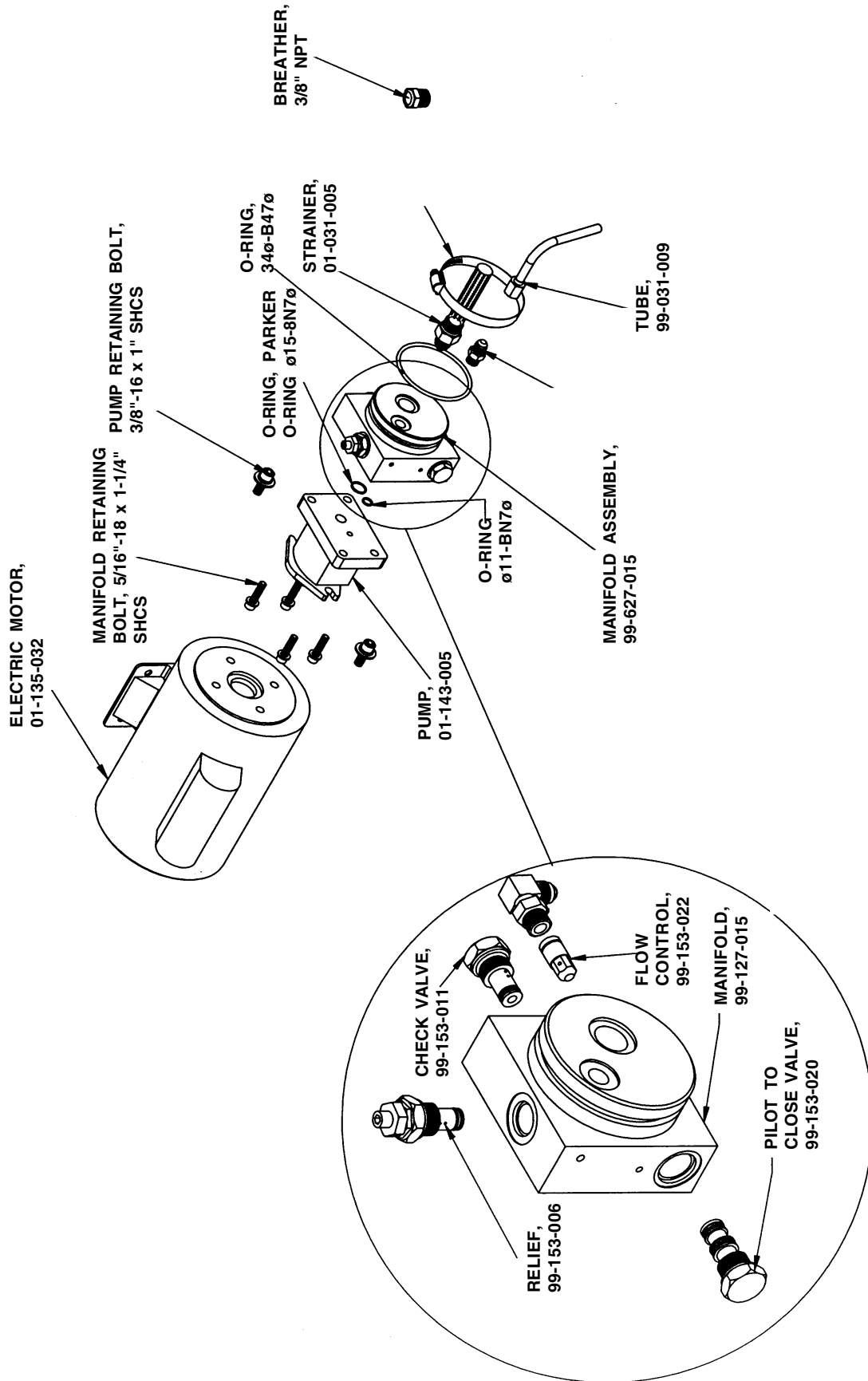

EDGE-O-DOCK FM SERIES

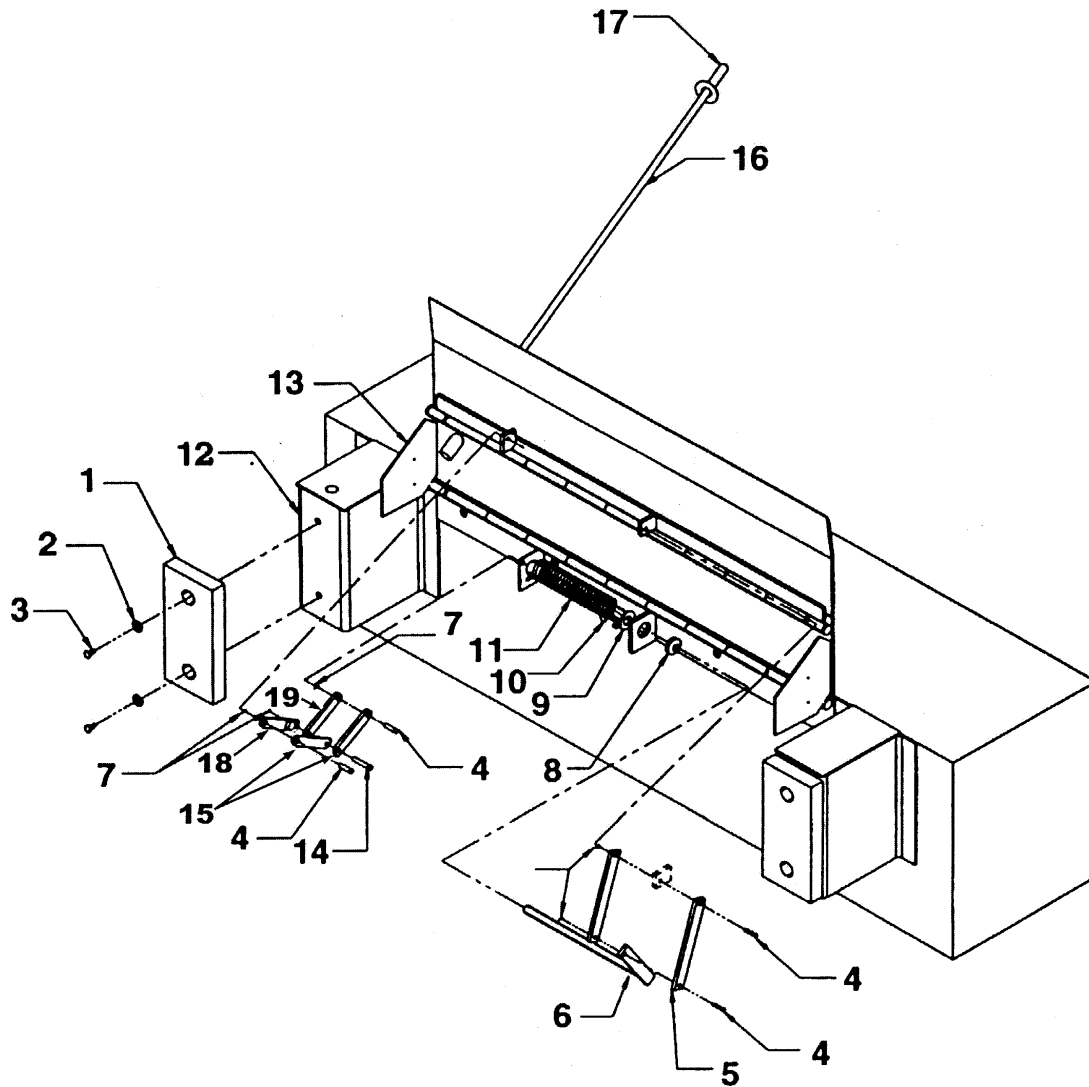

**PARTS IDENTIFICATION EDGE-O-DOCK
FM SERIES**

KIT CODE	ITEM NO.	DESCRIPTION	ENGINEER NO.	PART NO.	QTY
A	1	Rubber bumper	29-001-001	EOD-RB	2
A, D	2	Washer, 5/8"	33015	EOD-WSR	4
A,D	3	Bolt 5/8"-11 UNC x 2 1/2"	11313	EOD-BOLT1	4
B, D, E	4	Pin, 1/2" dia. x 1-3/4"	06-112-003	EOD-RP1	4
B,E	5	Secondary linkage arm	07-040-003	EOD-SLA	2
B,E	6	Main linkage arm	07-612-001	EOD-MLA	1
B, D,E	7	Cotter pin, 1/8" x 1-1/8"	65125	EOD-CP1	5
C,E	8	Sealed roller bearing	07-110-001	EOD-SRB	1
E	9	Adjustment Collar	07-518-001	EOD-AC	1
C, D,E	10	Bolt, 1/2"-13 UNC x 1"	13205	EOD-BLT2	1
C,E	11	Torsion spring	07-146-009	EOD-TS	1
	12	Bumper block	30-048-001	EOD-BB	2
	13	Toe guard (welding required)	07-024-002	EOD-TG	2
	14	Pin, 1/2" dia. x 2" long	07-112-007	EOD-CP2	1
	15	Lip Extension Arm	07-016-018	EOD-LEA	4
	16	Handle	07-025-004	EOD-HDL	1
	17	Grip	07-025-005	EOD-PG	1
	18	Link Arm 2 (block welded on)	07-516-009	EOD-LEA-2	1
	19	Link Arm 3 (knob on end)	07-016-021	EOD-LEA-3	1
A		Replacement bumper kit (items 1-3)	07-154-001	EOD-KIT-A	1
B		Replacement linkage kit (items 4-7)	07-154-002	EOD-KIT-B	1
C		Replacement spring kit (items 8,10,11)	07-154-004	EOD-KIT-C	1
D		Hardware kit (items 2-4,7,10)	07-154-003	EOD-KIT-D	1
E		Mechanical Kit (items 4-11)	07-154-005	EOD-KIT-E	1
F		Counter Balance Kit	07-154-006	EOD-KIT-F	1
G		Linkage Kit	07-154-008	EOD-LKK	

EDGE-O-DOCK • PP AND PE SERIES

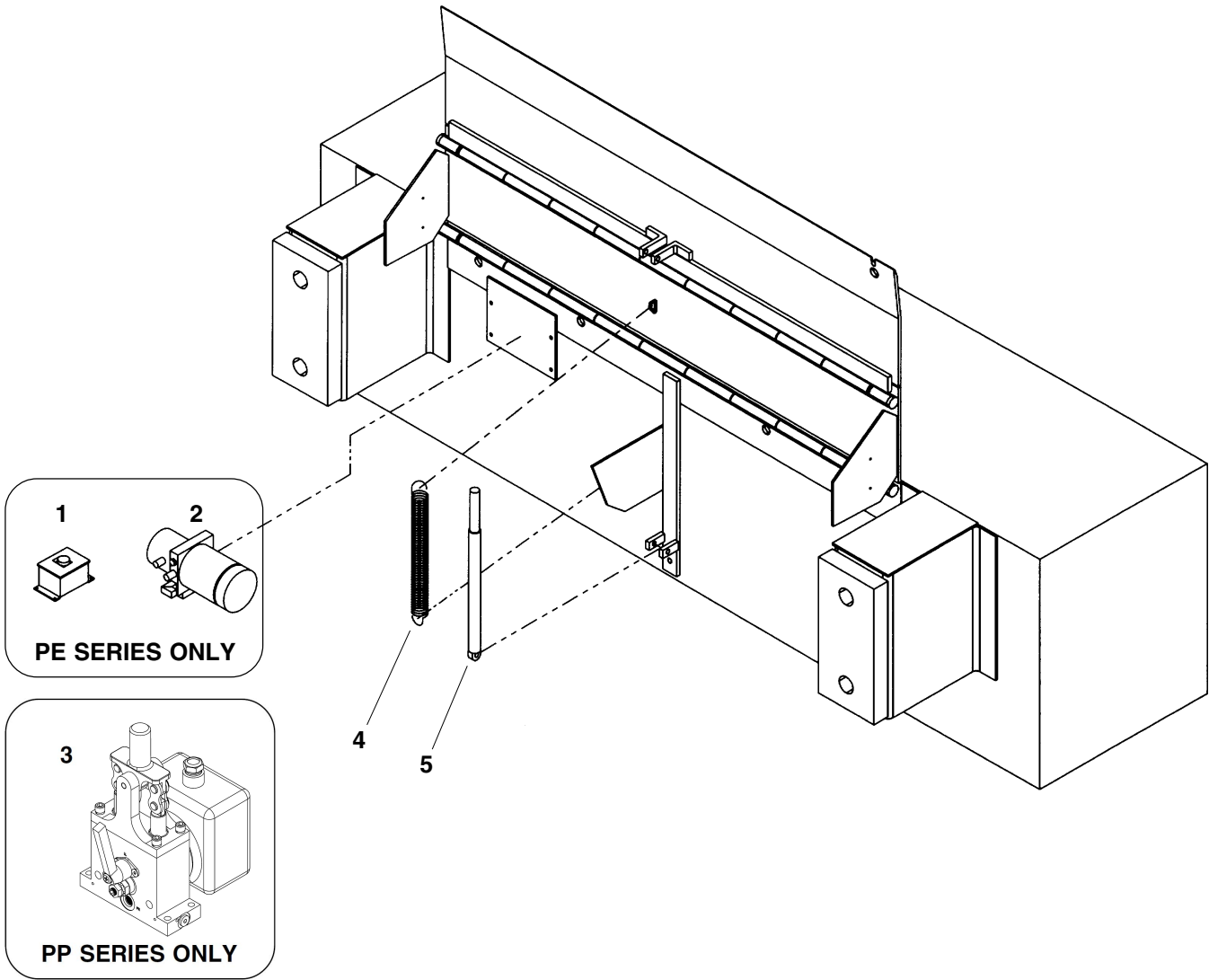

PARTS IDENTIFICATION EDGE-O-DOCK • PP AND PE SERIES

ITEM NO.	DESCRIPTION	ENGINEER NO.	PART NO.	QTY
1	Control box	PE-CONBOX	PE-CONBOX	1
2	Power unit	PE-MOPU	PE-MOPU	1
3	Handpump	99-640-003-003	PP-HDPUMP	1
4	Extension spring	15-146-001	EOD-ES	1
5	Hydraulic cylinder, 1" dia. x 14"	06-021-001	EOD-HC	1
6	PP Hose Kit	06-623-007	EOD-PP-HK	1
7	PE Hose Kit	06-623-006	EOD-PE-HK	1
8	Cylinder Retaining Bolt	n/a	EOD-PP-PE-CYLP	2

WARNING LABEL IDENTIFICATION

MAKE SURE ALL WARNING LABELS ARE IN PLACE!

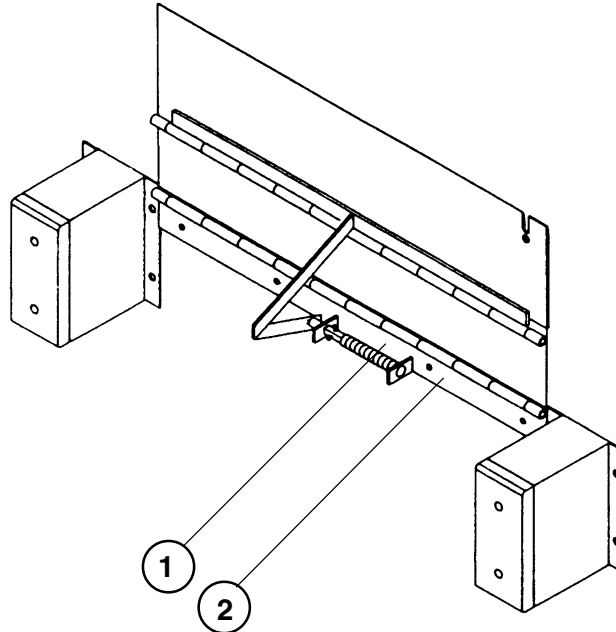

FM MODEL SHOWN

*Product safety signs or labels should be periodically inspected and cleaned by the product users as necessary to maintain good legibility for safe viewing distance ...
ANSI 535.4 (10.21)
Contact manufacturer for replacement labels.

1 FM SERIES ONLY

DECREASE COUNTER BALANCE
REDUCIR EL CONTRA BALANCE
DIMINUER LE CONTRE-POIDS

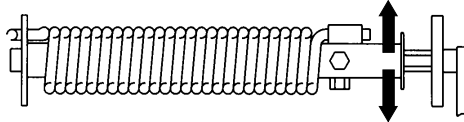

INCREASE COUNTER BALANCE
INCREMENTAR EL CONTRA BALANCE
AUGMENTER LE CONTRE-POIDS

244

2 FM SERIES ONLY

CAUTION	PRECAUCION	PRUDENCE
<p>CONSULT OWNERS MANUAL BEFORE ADJUSTING</p> <p>SECURE AND HOLD LIP IN VERTICAL POSITION. HOLD SQUARE TUBING SECURELY BEFORE LOOSENING LOCKING BOLTS WITH ANOTHER WRENCH. ADJUST IN DESIRED DIRECTION, THEN TIGHTEN LOCKING BOLTS ON FLATS OF INTERIOR ROUND BAR. CHECK FOR LIFTING EFFORT AND REPEAT OPERATION IF NEEDED. LIP AND PLATE SHOULD NOT FLOAT WHEN LIP IS EXTENDED. DECREASE COUNTERBALANCE IF NEEDED. GREASE HINGES, OIL LINKAGE, AND CHECK FOR WEAR MONTHLY.</p> <p>T & S EQUIPMENT CO. ANGOLA, IN</p>	<p>CONSULTE EL MANUAL DEL PROPIETARIO ANTES DE AJUSTAR</p> <p>ASEGURE Y MANTENGA LA CEJA EN POSICION VERTICAL. MANTENGA EL TUBO CUADRADO DE FORMA SEGURA ANTES DE SOLTAR LOS PERNOS CON OTRA LLAVE. AJUSTE EN LA DIRECCION DESEADA. ENTONCES APRIETE LOS PERNOS DE SEGURO EN LAS PARTES PLANAS DE LA BARRA INTERIOR. COMPRUEBE EL ESFUERZO DE LEVANTAMIENTO Y REPITA LA OPERACION SI ES NECESARIO. LA CEJA Y LA PLATAFORMA NO DEBEN FLOTAR CUANDO LA CEJA ESTA EXTENDIDA. REDUZCA EL CONTRABALANCE SI ES NECESARIO. ENGRASE LAS BISAGRAS, FUGAS DE ACEITE, Y REVISE POR DESGASTE MENSUALMENTE.</p> <p>T & S EQUIPMENT CO. ANGOLA, IN</p>	<p>CONSULTER LE MANUEL DU PROPRIÉTAIRE AVANT D'AJUSTER</p> <p>ASSURER ET MAINTENIR LE REBORD EN POSITION VERTICALE. BIEN TENIR LE TUBE CARRÉ AVANT DE DESSERRER LES BOULONS DE VERROUILLAGE AVEC UNE AUTRE CLÉ. AJUSTER À LA POSITION DÉSIRÉE. PUIS SERRER LES BOULONS SUR LES SURFACES PLANES À L'INTÉRIEUR DE LA BARRÉ. VÉRIFIER L'EFFORT D'ÉLEVATION ET RÉPÉTER L'OPÉRATION SI NÉCESSAIRE. LE REBORD ET LA PLAQUE NE DEVRAIENT PAS FLOTTER LORSQUE LE REBORD EST ÉTENDU. RÉDUIRE LE CONTRE-POIDS SI NÉCESSAIRE. GRAISSER LES CHARNIÈRES, HUILER LES JOINTURES ET VÉRIFIER L'USURE MENSUELLEMENT.</p> <p>T & S EQUIPMENT CO. ANGOLA, IN 245</p>

3 PP & PE SERIES ONLY LOCATED ON HAND PUMP OR POWER UNIT

ISO AW-32

HYDRAULIC OIL OR EQUIVALENT

ACEITE HIDRÁULICO O EQUIVALENTE

HUILE OU ÉQUIVALENT

206

4 PE SERIES ONLY LOCATED ON POWER UNIT

NOTICE | NOTA | AVIS

POWER SUPPLY: 115 Volt/1 Phase/60 HZ
CONTROL VOLTAGE: 24 VOLT AC

CORRIENTE: 115 Volt/1 Fase/60 HZ
VOLTAJE DE CONTROL: 24 VOLT CA

ALIMENTATION ÉLECTRIQUE: 115 Volt/1 Phase/ 60 HZ
VOLTAGE DE CONTRÔLE: 24 VOLT AC

248